

Check valve Shuttle

$Q_{\max} = 75 \text{ l/min}$, $p_{\max} = 350 \text{ bar}$

ball type

Type series: WRVC-G-10-...



- Screw-in cartridge valve
- Shuttle valve
- Lower Δp compared to check valves made by other manufacturers
- Virtually leak-proof in closed condition
- High pressure rating

Description

The WRVC series shuttle valve is characterized by very high pressure load capacity and extremely low Δp . The 3-way shuttle valve shuts off whichever of the inlet ports A or B is at the lower pressure. Port C is thus always connected to the higher pressure. The shuttle valve in ball-type design is very robust, extremely le-

ak-proof and insensitive to contamination. Valve seat, ball and body are hardened. External O-rings and a backup ring seal the leakage path between the valve and cavity wall. The valve is available in nominal sizes 04, 06, 08 and 10.

Symbol

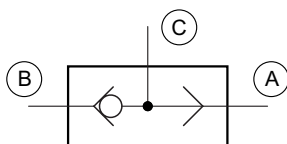

Technical Data

General Characteristics	Description, value, unit
Function group	Check valve
Function	Shuttle
Design	Screw-in cartridge valve
Characteristic	ball type
Construction size	nominal size 10
Thread size	G 1/2"
Mounting attitude	unrestricted
Weight	0.075 kg
Tightening torque steel	40 Nm

Hydraulic Characteristics	Description, value, unit
Maximum operating pressure	350 bar
Maximum flow rate	75 l/min
Nominal flow rate	50 l/min
Flow direction	see symbol
Hydraulic fluid	HL and HLP mineral oil according to DIN 51 524; other fluids on request!
Minimum fluid temperature	- 30 °C
Maximum fluid temperature	+ 80 °C
Viscosity range	10 ... 500 mm ² /s (cSt)
Minimum fluid cleanliness (cleanliness class according to ISO 4406:1999)	class 20/18/15

i **NOTE!**
For other values please contact Bucher Hydraulics.

Performance graphs

measured with oil viscosity 33.0 mm²/s (cSt)

$\Delta p = f(Q)$ Pressure drop-flow rate characteristic

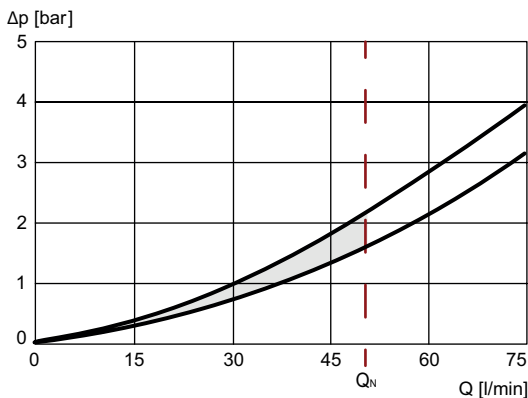

Dimensions and sectional view

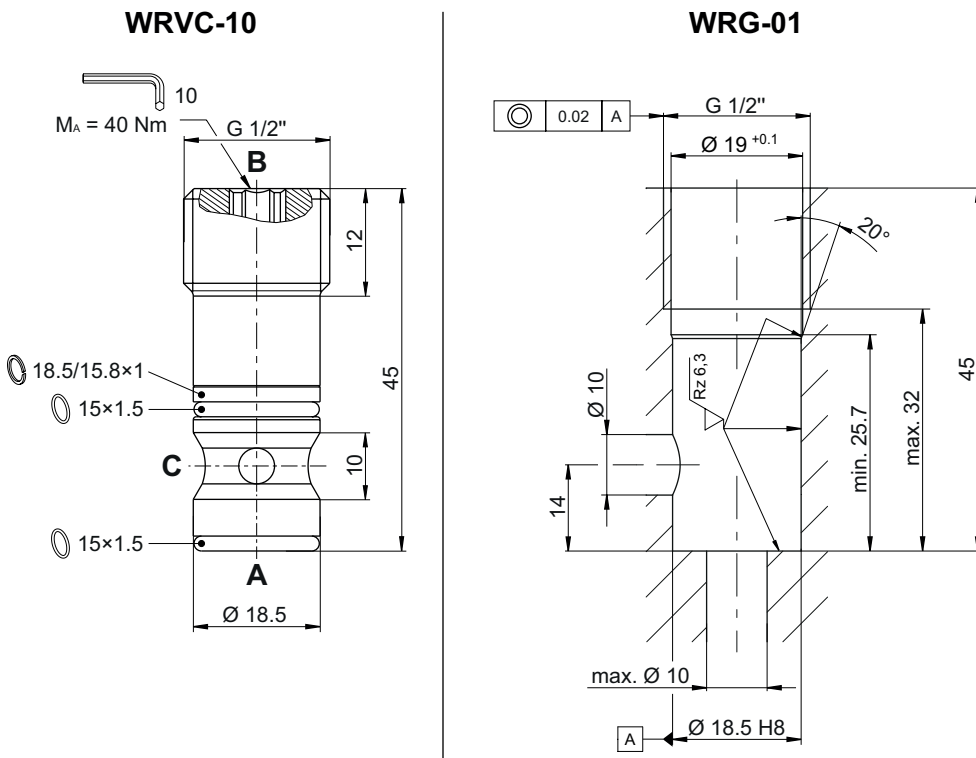

WRVC-10 = shuttle valve / screw-in cartridge valve

WRG-01 = dimension of the cavity for screw-in cartridge WRVC-10

The dimensions specified apply to the mounted state.

Installation information



NOTE!

When fitting the screw-in cartridge valve, use the specified tightening torque. The value can be found in the chapter technical data. Orifices or nozzles are to be placed after the check valve. If this is not possible, a right-angled bore must be designated between the check valve and the nozzle. (see data sheet 170-P-059000). Recommendation: before installing the valve, fit the O-ring in the cavity.



ATTENTION!

When fitting the valve, make sure that it is firmly seated on the sealing surface and that it is not deformed by the use of excessive force.

Application Notes



NOTE!

The maximum operating pressure must not be exceeded even when pressure peaks occur. In applications such as accumulator circuits, where sudden pressure can be applied to the valve in the free-flow direction, ensure that the specified flow ratings are not exceeded. Buyers bear the sole responsibility for ensuring that the valve is suitable for their applications and must be substantiated by trials or testing, if necessary.

Ordering code

Ex. WRVC - G - 10 - _

WRVC = shuttle valve, spherical poppet design, screw-in cartridge

G = whitworth pipe thread G1/2"

10 = nominal size 10, Q_{Nominal} 50l/min

(blank) = NBR (nitril-butadien-rubber / BUNA) seals (*standard*)

V = FKM (fluorocarbon rubber / VITON) seals

Related data sheets

Reference	Description
170-P-059000	Using nozzles or orifices before a Check Valve