

Flow valve

Flow control valve

$Q_{\max} = 100 \text{ l/min}$, $p_{\max} = 315 \text{ bar}$

direct acting, load-compensated, proportional solenoid with emergency override

Type series: SRCB-SNT-3



- Screw-in cartridge valve
- ZnNi plating (720h DIN EN ISO 9227 NSS)
- The slip-on coil can be rotated, and it can be replaced without opening the hydraulic envelope
- 3-way flow control valve
- Flow rates are unaffected by changes in temperature and load
- Compact construction
- Various plug-connector systems and voltages are available

Description

The flow control valve, series SRCB... is a direct acting, load compensated screw-in valve with an M42x1,5 mounting thread. This valve is used to set the working speed of hydraulic actuators, the setting being load-independent. The higher pressure can be at either the constant flow (port A) or surplus flow port (port B). The special orifice design ensures that the flow setting is largely independent of the viscosity of

the fluid. The cartridge design allows the valve to be installed in any customized control block. All external parts of the screw-in valve are zinc-nickel plated and are thus suitable for use in the harshest operating environments. The slip-on coil can be replaced without opening the hydraulic envelope and can be positioned at any angle through 360°.

Symbol

SRCB-S-3

SRCB-N-3
SRCB-T-3

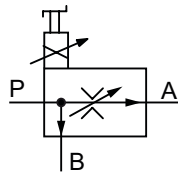
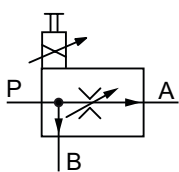

Technical data

General characteristics	Description, value, unit
Function group	Flow valve
Function	Flow control valve
Design	Screw-in cartridge valve
Controls	proportional solenoid with emergency override
Characteristic	direct acting, load-compensated
Neutral position	closed orifice
MTTFd value	150 years
Thread size	M42×1,5
Mounting attitude	unrestricted, preferably vertical, coil down (automatic air bleed)
Tightening torque aluminium	50 Nm
Minimum ambient temperature	- 30 °C
Maximum ambient temperature	+ 50 °C
Surface protection	ZnNi plating (720h DIN EN ISO 9227 NSS)
Sealing material	FKM (fluorocarbon rubber / VITON) seals

Hydraulic characteristics	Description, value, unit
Maximum operating pressure	315 bar
Maximum flow rate	100 l/min ¹⁾
Control flow range	10, 16, 25, 32, 40, 50, 63, 80 l/min ¹⁾
Flow direction	see symbol
Hydraulic fluid	HL and HLP mineral oil according to DIN 51 524; other fluids on request!
Minimum fluid temperature	- 20 °C
Maximum fluid temperature	+ 80 °C
Viscosity range	10 ... 300 mm ² /s (cSt)
Minimum fluid cleanliness (cleanliness class according to ISO 4406:1999)	class 20/18/15
Min. pressure difference (pressure compensator)	7 bar
Control accuracy (as a % of the nominal flow)	Load-dependency when under pressure: max. ± 2.5 % ²⁾ Hysteresis when operated: max. ± 3.5 % ²⁾
Internal leakage flow rate	max. 100 cm ³ /min at 100 bar ¹⁾

NOTE!

- 1) Values refer to an oil viscosity of 35 mm²/s (cSt).
 2) Values refer to the selected flow range.

NOTE!

For other values please contact Bucher Hydraulics.

Electric characteristics	Description, value, unit
Solenoid coils type	D45/22
Features solenoid coil	pressure-tight, switching in oil
Supply voltage DC	12/24 V DC from an electronic controller
Maximum permissible power consumption	21 W with 12 V coil and $I_{max} = 2,3$ A 21 W with 24 V coil and $I_{max} = 1,15$ A W
Relative duty cycle	100 % at I_{max}
Recommended PWM frequency	100 Hz (observe I_{max})
Electrical connection coil	several connection types available, see ordering code
Protection class solenoid coil to ISO 20 653 / EN 60 529	several classes of protection available, see ordering code (with appropriate mating connector and proper fitting and sealing)

i NOTE!
For other values please contact Bucher Hydraulics.

Performance graphs

measured with oil viscosity 35.0 mm²/s (cSt)

$Q = f(\%; \text{mA})$ Flow rate adjustment characteristic

Q [%]

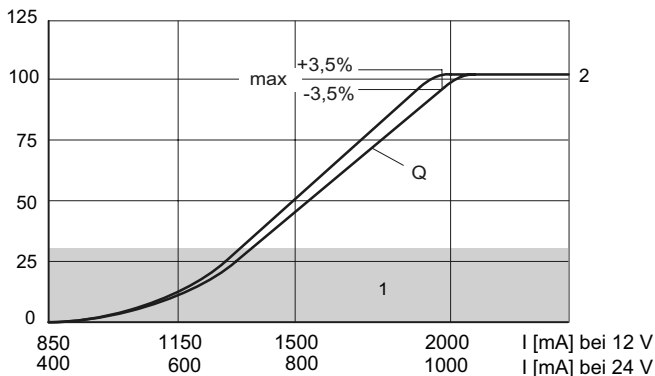

1 = Fine control range
2 = 100% = 2000 ± 200 mA bei 12 V DC
 1000 ± 100 mA bei 24 V DC
(100%- values vary with nominal flow rate)

$Q = f(p)$ Flow rate load-pressure

Q_A [l/min]

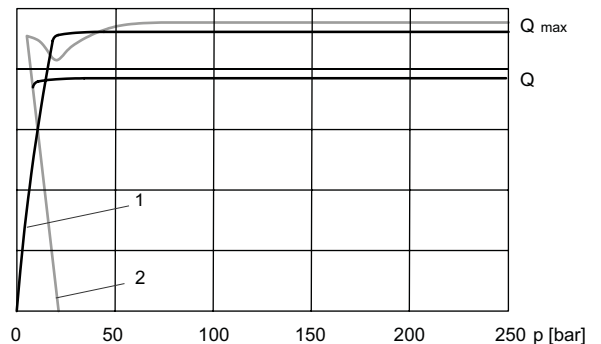

1 = Q_A - Constant flow pressurised
2 = Q_B - Surplus flow pressurised

$\Delta p = f(Q)$ Pressure drop-flow rate characteristic

Δp [bar]

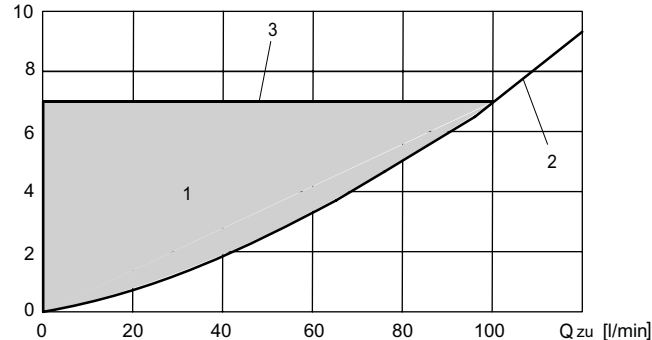

1 = Pressure loss area (The actual pressure-loss characteristic is dependent on the tank pressure at port B)
2 = Control valve throttling curve (Dependent on applied body)
3 = Control Δp - characteristic 7 bar

Dimensions and sectional view

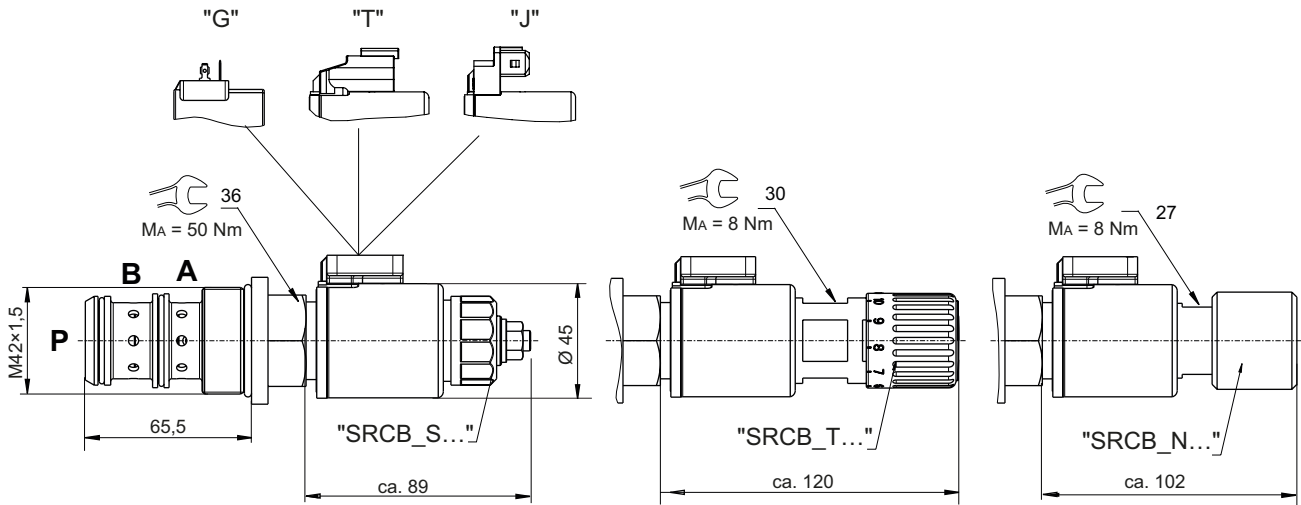

Installation information



ATTENTION!

Expert and product knowledge is required for the layout of this valve type. Use exclusively for the intended purpose within the indicated values. The valve manufacturer must be consulted for use of the appliance outside the specifications. All applications must be verified by sufficient tests to ensure safety in the application. The ultimate responsibility for safety during installation and use resides with the end appliance manufacturer. All limit values listed in the data sheet apply to typical mobile hydraulic applications with a max. rate of pressure rise of 4000 bar (higher values after consultation).



ATTENTION!

Only qualified personnel with mechanical skills may carry out any maintenance work. Generally, the only work that should ever be undertaken is to check, and possibly replace, the seals. When changing seals, oil or grease the new seals thoroughly before fitting them.



NOTE!

When fitting the screw-in cartridge valve, use the specified tightening torque. The value can be found in the chapter "Technical data". We offer form tool sets for sale or hire. Description: 1835 A D32 (Id. No.: 100603875).



NOTE!

Bleed all air from the system (if possible, operate valve several times without load).

Models of the emergency override

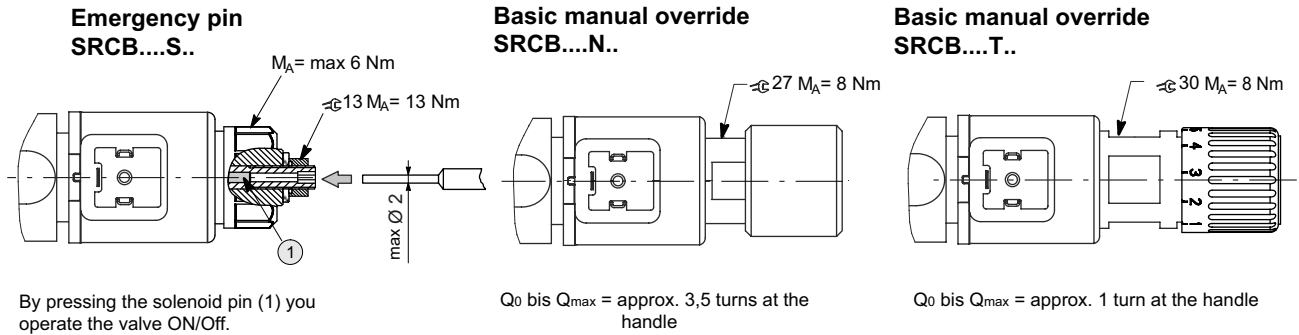

Application examples

Possible applications can be:

- Harvesters
- Sweepers
- Refuse collection vehicles
- Fertiliser spreaders
- Snow and ice clearin equipment
- Mowers
- Road rollers
- Municipal vehicles
- Forestry machines
- Wood chippers
- ...

Ordering code

SR C B 032 N 3 - 1 G 12 /

- SR = Flow control valve
- C = Cartridge
- B = Size
- 010 = Constant flow range 10 l/min
- 016 = Constant flow range 16 l/min
- 025 = Constant flow range 25 l/min
- 032 = Constant flow range 32 l/min
- 040 = Constant flow range 40 l/min
- 050 = Constant flow range 50 l/min
- 063 = Constant flow range 63 l/min
- 080 = Constant flow range 80 l/min
- Type of operator**
- S = Proportional solenoid + emergency pin
- N = Proportional solenoid + basic manual override
- T = Proportional solenoid + deluxe manual override
- 3 = 3-way flow control valve
- 1...9 = Design stage (to be inserted by the factory)
- Plug connector**
- G = GDM Plug DIN EN 175301-803, 3-pole, 2 P+E (IP65)
- J = AMP Junior Timer (IP65)
- T = Deutsch plug DT04-2P-EP04 (IP 67)
- 12 = Proportional solenoid supply voltage DC 12 Volt
- 24 = Proportional solenoid supply voltage DC 24 Volt
- Options (to be inserted by the factory)

Related data sheets

Reference	Description
100-D-400971	Cavity GB3NM42