

Check valve

Spring loaded check

$Q_{\max} = 225 \text{ l/min}$, $p_{\max} = 350 \text{ bar}$
poppet type, hydraulic operation
Type series: CVFP-16-...

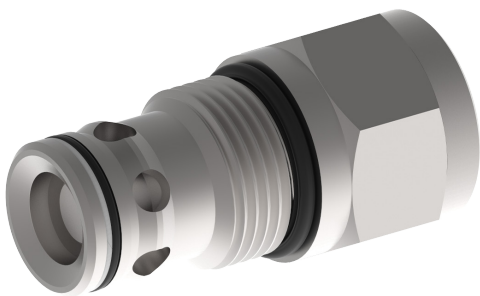

- Screw-in cartridge valve
- For cavity C1620
- All external parts zinc plated, chromited (CrVI-free)
- Installation in threaded port body type B1620
- Wide selection of bias springs allows flexibility for back-pressure application

Description

This unit is a screw-in cartridge style, guided poppet, hydraulic check valve, for use as a blocking or load holding device for high pressure applications. This

valve allows free flow from port 1 to port 2 and blocks flow from port 2 to port 1 or holding a load.

Symbol

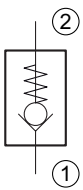

Technical data

General Characteristics	Description, value, unit
Function group	Check valve
Function	Spring loaded check
Design	Screw-in cartridge valve
Controls	hydraulical operation
Characteristic	poppet type
Construction size	SAE 16 / nominal size 12
Thread size	1 5/16-12 UN-2A
Mounting attitude	unrestricted
Weight	0.39 kg
Cavity acc. factory standard	For cavity C1620
Tightening torque steel	132.5 Nm
Tightening torque aluminium	98.5 Nm
Tightening torque tolerance	± 5 %
Minimum ambient temperature	- 30 °C
Maximum ambient temperature	+ 120 °C
Surface protection	All external parts zinc plated, chromited (CrVI-free)
Available seal types	several seal types available, see ordering code
Seal kit order number	NBR: SKN-1621 / FKM: SKV-1621

Hydraulic Characteristics	Description, value, unit
Maximum operating pressure	350 bar
Maximum flow rate	225 l/min
Flow direction	see symbol
Hydraulic fluid	All general purpose hydraulic fluids such as MIL-H-5606, SAE-#10, SAE-#20, etc.
Minimum fluid temperature	- 25 °C
Maximum fluid temperature	+ 80 °C
Viscosity range	10 ... 500 mm ² /s (cSt)
Recommended viscosity range	15 ... 250 mm ² /s (cSt)
Minimum fluid cleanliness (cleanliness class according to ISO 4406:1999)	class 18/16/13
Internal leakage flow rate	5 drops/min maximum at 350 bar

Performance graphs

measured with oil viscosity 28.5 mm²/s (cSt)

$\Delta p = f(Q)$ Pressure drop-flow rate characteristic

Δp [psi (bar)]

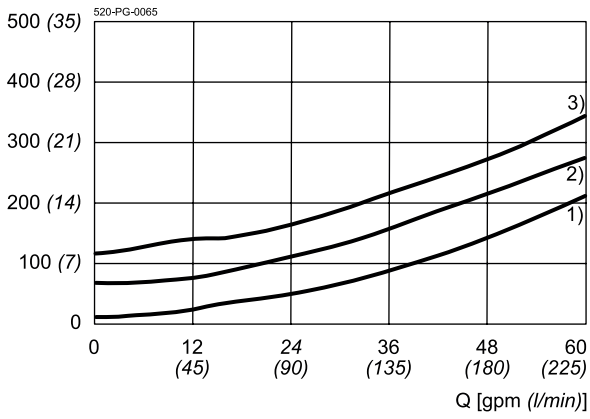

- 1) = p_N 5 psi (0.35 bar)
- 2) = p_N 60 psi (4.0 bar)
- 3) = p_N 120 psi (8.0 bar)

Dimensions and sectional view

**Beispiel für die Masseinheit:
Example for the dimensional units:**

.031 = 0.031" inch
(0.79) = 0.79 mm millimeter

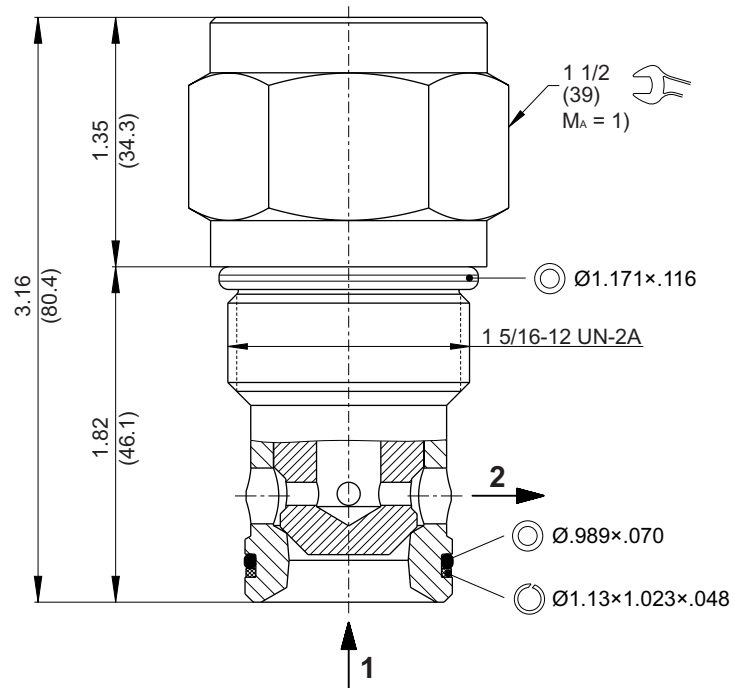

Installation information



ATTENTION!

Only qualified personnel with mechanical skills may carry out any maintenance work. Generally, the only work that should ever be undertaken is to check, and possibly replace, the seals. When changing seals, oil or grease the new seals thoroughly before fitting them.



NOTE!

1) When fitting the screw-in cartridge valve, use the specified tightening torque. The value can be found in the chapter "Technical data".



NOTE!

The seals are not available individually. The seal kit order number can be found in the chapter "Technical data".

Ordering code

e.g. CVFP - 16 - N - 0 - 005

- CVFP = spring loaded check valve
- 16 = nominal size SAE 16 / NG 12
- N = NBR (nitril-butadien-rubber / BUNA) seals (*standard*)
- V = FKM (fluorocarbon rubber / VITON) seals
(*special seals - please consult BUCHER*)
- 0 = screw-in cartridge only
- 12TA = line-mounting body aluminum SAE #12 ports
- 12TS = line-mounting body steel SAE #12 ports
- 16TA = line-mounting body aluminum SAE #16 ports
- 16TS = line-mounting body steel SAE #16 ports
- 005 = opening pressure 5 psi
- 015 = opening pressure 15 psi
- 030 = opening pressure 30 psi
- 060 = opening pressure 60 psi
- 120 = opening pressure 120 psi

Related data sheets

Reference	Description
520-P-000050	Form tools
520-P-000140	Cavity C1620
520-P-000141	Threaded port body B1620