

Pipe Rupture Valves

$Q_{\max} = 580 \text{ l/min [153 gpm]}$, $p_{\max} = 350 \text{ bar [5000 psi]}$

Seat valve as screw-in cartridge or mounted in a body

Series RS...-P-... / RS...-W-...

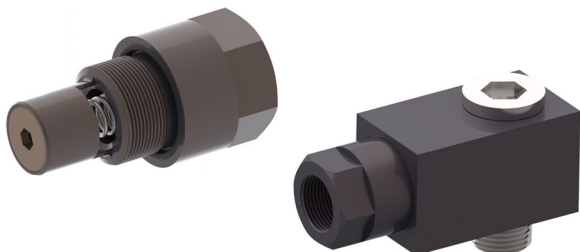

- Nearly leak-free closure
- Closing flow rate is adjustable
- Simple pipework installation
- Compact design means small space requirements
- Available as a cartridge or in a block body
- Exposed parts with burnished finish

1 Description

Series RS...-P-... / RS...-W-..., pipe rupture valves, which belong to the safety valves group, are available as screw-in cartridges or as a body-mounted design. Pipe rupture valves are used wherever a load must not be allowed to drop rapidly and without control if a pipe or hose bursts (ex. uncontrolled movement of the cylinder). In its normal posi-

tion the pipe rupture valve is open and allows the flow in both directions. When the actuating flow rate is exceeded – by a hose burst, for example – the pipe rupture valve closes suddenly and blocks flow from Z to P. The pipe rupture valve opens again automatically when the pressure at port P is higher than the pressure at port Z.

2 Symbol

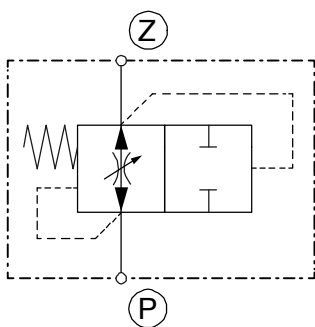

3 Technical data

General characteristics	Description, value, unit
Designation	Pipe Rupture Valve
Design	Ball/seat valve
Mounting method	Screw-in cartridge or mounted in a body
Tightening torque	See section 6, Dimensions & sectional view
Size	08, 12, 16, 20, 25 and 32
Weight	See section 6, Dimensions & sectional view
Mounting attitude	unrestricted

General characteristics	Description, value, unit	
Ambient temperature range	-20 °C ... +80 °C (others on request)	[-4 °F ... +176 °F]
Surface corrosion protection	burnished	
Hydraulic characteristics	Description, value, unit	
Maximum operating pressure	size 08, 12, 16, 20, 25 size 32	350 bar [5000 psi] 300 bar [4300 psi]
Minimum adjustable actuating flow rate (size 08)	5 l/min	[1.3 gpm]
Maximum adjustable actuating flow rate (size 32)	580 l/min	[153 gpm]
Flow direction	P → Z, free flow Z → P, no-flow direction	
Hydraulic fluid	HL and HLP mineral oil to DIN 51 524; for other fluids, please contact BUCHER	
Hydraulic fluid temperature range	-20 °C ... +80 °C	[-4 °F ... +176 °F]
Viscosity range	10...650 mm ² /s (cSt), recommended 15...250 mm ² /s (cSt)	
Minimum fluid cleanliness Cleanliness class to ISO 4406 : 1999	class 20/18/15	



IMPORTANT!: The set closing volume flow must be at least 40 % above the maximum operating flow rate.

4 Construction and function

1. When oil flows through from Z → P, if the pressure difference in the valve rises above the preload value (approx. 1 bar), then the ball is pressed against the valve seat and shuts off the flow cross section.
2. The pipe rupture valve opens again automatically when the pressure at port P is higher than the pressure at port Z.



ATTENTION!:

Due to their very high closing speed, these products are not suitable for applications that include the transportation of people. The activation of the pipe rupture valve produces very large decelerations that can have adverse health effects.

Notes on setting the closing flow rate

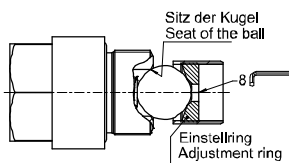

Screw in the adjusting ring until the ball is resting on the seat → basic position.

Set the required closing flow rate by unscrewing (anticlockwise) the adjusting ring back from the basic position.

(Diagram shows: basic position, 0 turns)

5 Performance graphs

measured with oil viscosity 33 mm²/s (cSt)

Q = f (X; no of turns)
Closing flow rate adjustment characteristic

Q [l/min (gpm)] Grösse / size 08

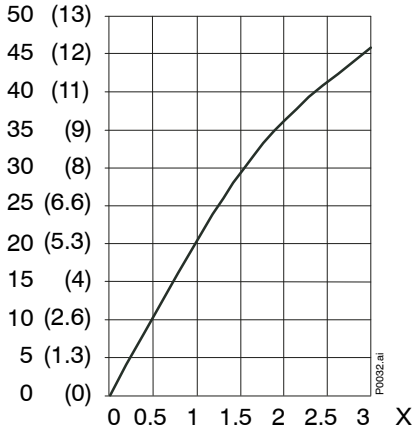

Q = f (X; no of turns)
Closing flow rate adjustment characteristic

Q [l/min (gpm)] Grösse / size 12

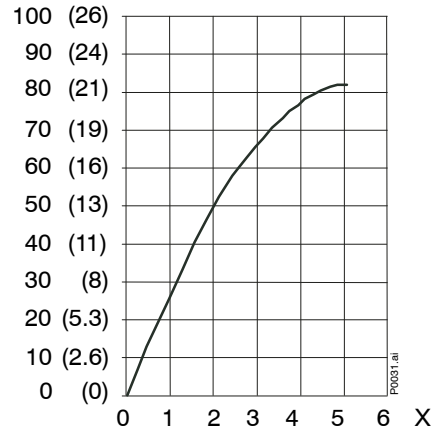

Q = f (X; no of turns)
Closing flow rate adjustment characteristic

Q [l/min (gpm)] Grösse / size 16

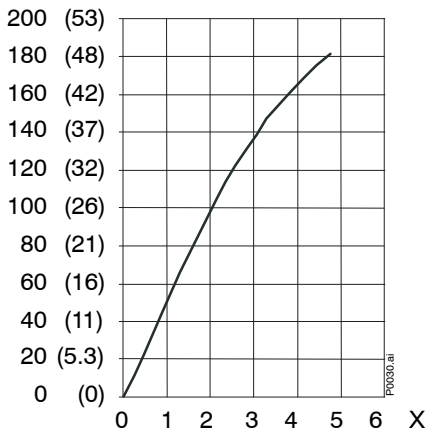

Q = f (X; no of turns)
Closing flow rate adjustment characteristic

Q [l/min (gpm)] Grösse / size 20

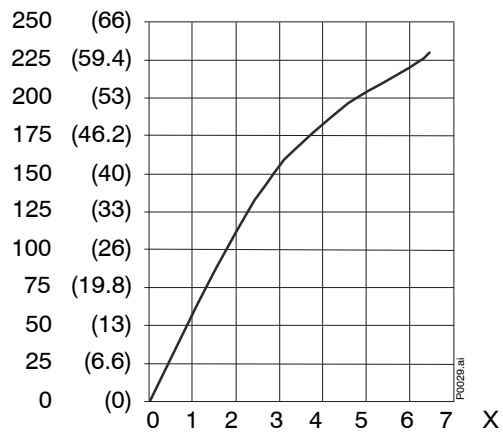

Q = f (X; no of turns)
Closing flow rate adjustment characteristic

Q [l/min (gpm)] Grösse / size 25

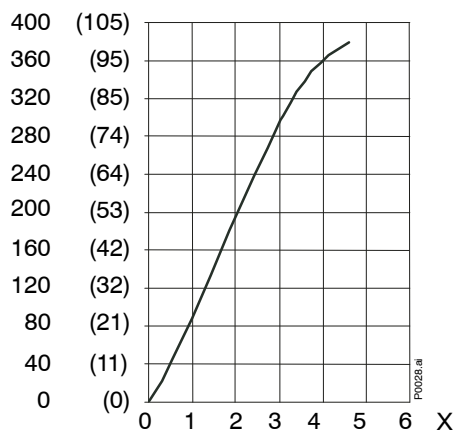

Q = f (X; no of turns)
Closing flow rate adjustment characteristic

Q [l/min (gpm)] Grösse / size 32

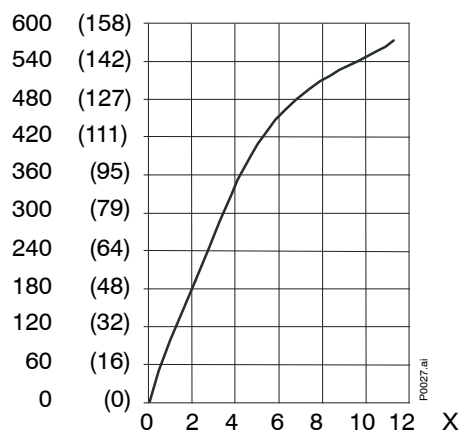

X = no. of turns of adjusting ring back from the basic position.

6 Dimensions & sectional view

6.1 Series RS...-P-...

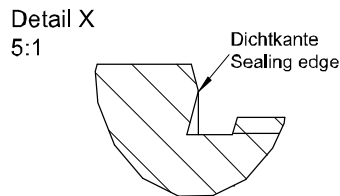
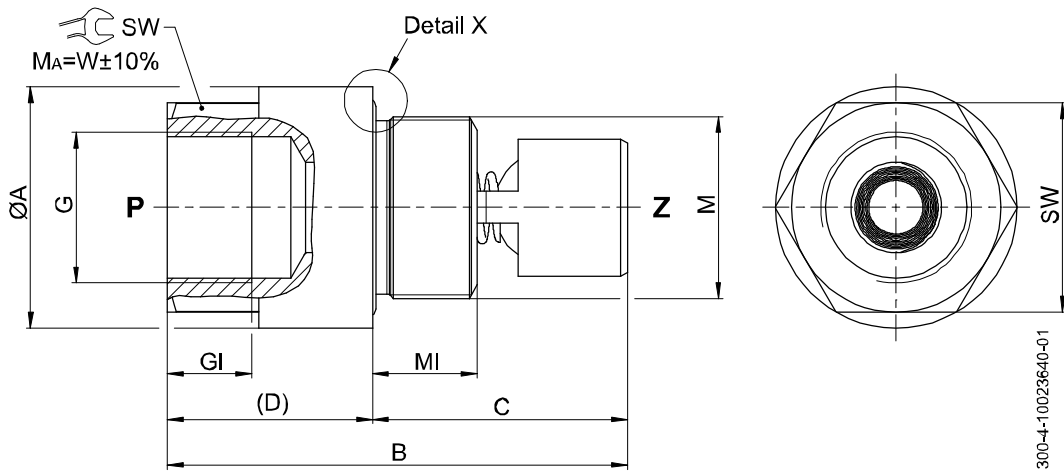

model / version A:
NS 08, 12, 16 with sealing edge

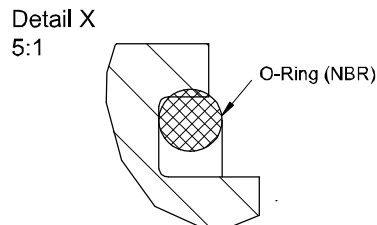

model / version B:
NS 20, 25, 32 with O-Ring (NBR)

Size RS...-P-	Max. actuating flow rate l/min [gpm]	P _{max} bar [psi]	ØA mm [inch]	B mm [inch]	C mm [inch]	(D) mm [inch]	G	GI mm [inch]	M	MI mm [inch]	SW mm [inch]	W Nm [lbf-ft]	Weight kg [lbs]
08	5...40 [1.3...11]	350 [5000]	Ø31.2 [1.22]	51 [2.00]	24 [.944]	(27) [(1.06)]	G ³ / ₈ "	12 [.472]	M22 x 1.5	9 [.354]	27 [1.06]	110 [80]	0.15 [0.33]
12	20...80 [5.3...21]	350 [5000]	Ø37 [1.45]	70 [2.75]	35 [1.37]	(35) [(1.37)]	G ¹ / ₂ "	15 [.590]	M28 x 1.5	15 [.590]	32 [1.25]	160 [120]	0.27 [0.59]
16	40...160 [11...42]	350 [5000]	Ø47.4 [1.86]	87 [3.42]	47 [1.85]	(40) [(1.57)]	G ³ / ₄ "	17 [.669]	M35 x 1.5	20 [.787]	41 [1.61]	240 [180]	0.53 [1.16]
20	50...200 [13...53]	350 [5000]	Ø53 [2.08]	101 [3.97]	56 [2.20]	(45) [(1.77)]	G1"	18.5 [.728]	M40 x 1.5	23 [.905]	46 [1.81]	420 [310]	0.78 [1.71]
25	80...360 [21...95]	350 [5000]	Ø63.5 [2.50]	123 [4.84]	78 [3.07]	(45) [(1.77)]	G1 ¹ / ₄ "	21 [.826]	M50 x 1.5	35 [1.37]	55 [2.16]	750 [555]	1.32 [2.91]
32	120...580 [32...153]	300 [4300]	Ø80.5 [3.17]	148 [5.82]	87.5 [3.44]	(60.5) [(2.38)]	G1 ¹ / ₂ "	23 [.905]	M64 x 2	37 [1.45]	70 [2.75]	1000 [740]	2.72 [5.99]

6.2 Series RS...-W-...

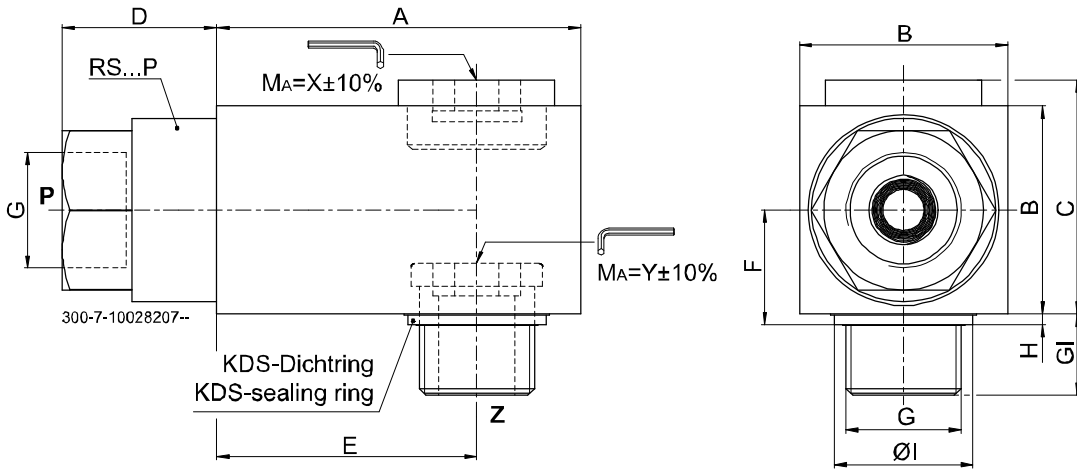

Size RS...-W-	Max. actuating flow rate l/min [gpm]	P _{max} bar [psi]	A mm [inch]	B mm [inch]	C mm [inch]	D mm [inch]	E mm [inch]	F mm [inch]	G	GI mm [inch]	H mm [inch]	ØI mm [inch]	X Nm [lb-ft]	Y Nm [lb-ft]	Weight kg [lbs]
08	5...40 [1.3...11]	350 [5000]	55 [2.16]	40 [1.57]	45 [1.77]	26.5 [1.04]	35 [1.37]	22.5 [.885]	G $\frac{3}{8}$ "	13.5 [.531]	2.5 [.098]	Ø22 [0.86]	130 [100]	60 [45]	0.74 [1.63]
12	20...80 [5.3...21]	350 [5000]	75 [2.95]	50 [1.96]	55.5 [2.18]	34.5 [1.35]	50 [1.96]	29 [1.41]	G $\frac{1}{2}$ "	14.5 [.570]	4 [.157]	Ø27 [1.06]	220 [165]	100 [75]	1.49 [3.28]
16	40...160 [11...42]	350 [5000]	95 [3.74]	60 [2.36]	67.5 [2.65]	39.5 [1.55]	65 [2.55]	33 [1.30]	G $\frac{3}{4}$ "	17.5 [.688]	3 [.118]	Ø33 [1.30]	275 [205]	170 [125]	2.64 [5.82]
20	50...200 [13...53]	350 [5000]	105 [4.13]	60 [2.36]	67.5 [2.65]	44.5 [1.75]	75 [2.95]	33 [1.30]	G1"	20.5 [.807]	3 [.118]	Ø40 [1.57]	275 [205]	250 [185]	3.00 [6.61]
25	80...360 [21...95]	350 [5000]	140 [5.51]	70 [2.75]	78.5 [3.09]	44.5 [1.75]	103 [4.05]	38 [1.50]	G1 $\frac{1}{4}$ "	22.5 [.885]	3 [.118]	Ø50 [1.96]	340 [250]	300 [225]	5.13 [11.3]
32	120...580 [32...153]	300 [4300]	155 [6.10]	90 [3.54]	98.5 [3.87]	60 [2.36]	114 [4.48]	48 [1.89]	G1 $\frac{1}{2}$ "	24.5 [.964]	3 [.118]	Ø56 [2.20]	440 [325]	350 [260]	9.57 [21.10]

7 Installation and commissioning



ATTENTION!

Only qualified personnel with mechanical skills may carry out any maintenance work. Generally, the only work that should ever be undertaken is to check, and possibly replace, the external seals. When changing seals, oil or grease the new seals thoroughly before fitting them.



ATTENTION!

The cartridge / valve must not be opened without the manufacturer's express permission, otherwise the warranty will be voided!



ATTENTION!

Secure the pipework in such a way that no radial forces act on port Z.



IMPORTANT!

The valve may only be used for its intended purpose within its nominal rating! If you plan to use it outside the nominal rating, you must contact the valve manufacturer.



IMPORTANT!

Release all hydraulic pressure from the system before any disassembly work.



IMPORTANT!

Protect seals and flange faces from damage. Pay attention to the port designations.

8 Ordering code

e.g.

RS	08	-	_	-	P	-	...	-	_
----	----	---	---	---	---	---	-----	---	---

- RS = Pipe Rupture Valve
- 08 = Size 08
- 12 = Size 12
- 16 = Size 16
- 20 = Size 20
- 25 = Size 25
- 32 = Size 32
- Model / version
- A = Screw-in cartridge with sealing edge (size 08, 12, 16)
- B = Screw-in cartridge with O-ring (size 20, 25, 32)
- P = Screw-in cartridge model
- W = Body-mounted model
- ... = Setting for actuating flow rate ¹⁾
- (blank) = With sealing edge (RS...-P... in sizes 08, 12, 16)
- N = NBR (nitrile) seals (all RS...-W-... and RS...-P-... in sizes 20, 25, 32) (special seals on application)



IMPORTANT!

¹⁾ must be min. 40% above max. operating flow rate!

9 Cavity type for series RS...-P-...

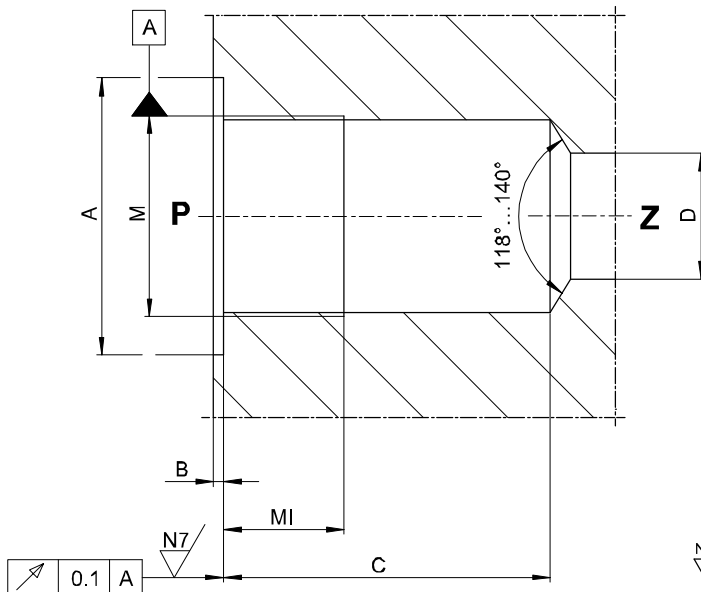

Allgemeintoleranzen nach: DIN ISO 2768-mK
General tolerances as per:

	N7/	N8/
$\sqrt{\frac{-0.1}{-0.3}}$		
$\sqrt{\frac{+0.3}{+0.1}}$		
Ra [µm]	1.6	3.2
Rz [µm]	10	16
Rmax [µm]	18	25

Series	A mm [inch]	B mm [inch]	C mm [inch]	D mm [inch]	M	MI mm [inch]
RS 08-A-P-...	min. Ø33 min. [1.29]	max. 2 max. [.078]	min. 34 min. [1.33]	min. Ø12 min. [.472]	M22 x 1.5	min. 10 min. [.393]
RS 12-A-P-...	min. Ø39 min. [1.53]	max. 10 max. [.393]	min. 45 min. [1.77]	min. Ø16 min. [.629]	M28 x 1.5	min. 16 min. [.629]
RS 16-A-P-...	min. Ø49 min. [1.93]	max. 15 max. [.590]	min. 57 min. [2.24]	min. Ø20 min. [.787]	M35 x 1.5	min. 21 min. [.826]
RS 20-B-P-...	min. Ø55 min. [2.16]	max. 25 max. [.984]	min. 66 min. [2.60]	min. Ø25 min. [.984]	M40 x 1.5	min. 24 min. [.944]
RS 25-B-P-...	min. Ø65 min. [2.55]	max. 23 max. [.905]	min. 88 min. [3.46]	min. Ø30 min. [1.18]	M50 x 1.5	min. 36 min. [1.41]
RS 32-B-P-...	min. Ø82 min. [3.22]	max. 35.5 max. [1.40]	min. 97.5 min. [3.83]	min. Ø38 min. [1.50]	M64 x 2	min. 38 min. [1.50]

info.ch@bucherhydraulics.com

www.bucherhydraulics.com

© 2024 by Bucher Hydraulics AG, CH-6345 Neuheim

All rights reserved.

Data is provided for the purpose of product description only, and must not be construed as warranted characteristics in the legal sense. The information does not relieve users from the duty of conducting their own evaluations and tests. Because the products are subject to continual improvement, we reserve the right to amend the product specifications contained in this catalogue.

Classification: 430.325.355