

4/2 and 4/3 Solenoid Directional Valve, ISO Size 03

$Q_{max} = 32 \text{ l/min}$, $p_{max} = 160 \text{ bar}$
direct acting, with EX-safety solenoid coil
Series FWKDX_-6...

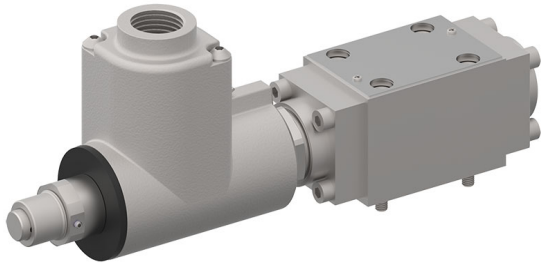

Valve:

- Solenoid coil can be rotated 360°
- With manual override
- Interface to ISO 4401-03-02

Solenoid coil:

- To EN 60079-0, EN 60079-1, EN 60079-31
- For equipment in category 2

ATEX and UKEX:

gas: Ex II 2G Ex db IIC T6 Gb

dust: Ex II 2D Ex tb IIIC T85 °C Db

Mining: Ex I M2 Ex db I Mb

IECEX:

gas: Ex Ex db IIC T6 Gb

dust: Ex Ex tb IIIC T85 °C Db

Mining: Ex Ex db I Mb

1 Description

Series FWKDX_-6... spool valves are direct acting units. The main valve components are a steel body, a spring-centered spool and wet armature solenoids with pressure-tight core tube and a slip-on coil which is certified for use in explosion-hazard areas. (II 2G/D). The solenoid housing is carbon steel protected against corrosion. The solenoid housing is threaded 1/2" NPT for a cable entry gland. The cable entry gland (which must be certified to IEC/EN 60079-1) is not supplied with the valve and, if required, must be ordered as a separate item. The spool is offset by the solenoid force and brought back to its de-energized position by return or centering springs.

Ex: Solenoid conforms to standards
IEC/EN 60079-0, IEC/EN 60079-7, IEC/EN 60079-18

Gas:

db: Flameproof enclosures

Group IIC: For use in the potentially explosive area

T6: Temperature class for gas

Gb: For use in Zone 1 (Zone 2) with foreseeable faults

Dust:

tb: protection by enclosure

Group IIIC: For use in flammable dust atmospheres

T85 °C: Temperature class for dust

Db: For use in Zone 21 (Zone 22) with foreseeable faults

Verification certificates:

EG-Type-Examination Certificate EPT 17 ATEX 2768X

IEC-Type-Examination Certificate IECEX EUT 17.0030X

UKEX-Type-Examination Certificate CML 22UKEX1078X

2 Technical data

General characteristics	Description, value, unit
Designation	4/2 and 4/3 solenoid directional valve
Design	manifold-mounting, direct acting
Mounting method	4 x $\varnothing 5,5$ holes for M5x45 cap screws
Tightening torque	5.2 Nm \pm 10 %
Size	size 03 interface to ISO 4401-03-02 / DIN 24 340 A6
Weight	2.7 kg (1 solenoid) 4.1 kg (2 solenoid)

General characteristics		Description, value, unit
Mounting attitude		horizontal recommended (vertical mounting makes air bleeding difficult)
Ambient temperature range		see hydraulic and electrical characteristics
MTTF _D values		150 years, see data sheet 400-P-010101-en
Hydraulic characteristics		Description, value, unit
Maximum operating pressure	port A, B and P port T	160 bar 100 bar
Maximum flow rate	C spool	32 l/min 18 l/min
Flow direction		see symbols
Hydraulic fluid		HL and HLP mineral oil to DIN 51 524; for other fluids, please contact BUCHER
Ambient temperature range ¹⁾		-30 °C ... +80 °C
Hydraulic fluid temperature range ¹⁾		-30 °C ... +80 °C ²⁾
Viscosity range		10...500 mm ² /s (cSt), recommended 15...250 mm ² /s (cSt)
Minimum fluid cleanliness Cleanliness class to ISO 4406 : 1999		class 20/18/15
Electrical characteristics		Description, value, unit
Supply voltage		standard 24V DC and 230V AC, other voltages available on request
Supply voltage tolerance		±10%
Ambient temperature range ¹⁾		-60 °C ... +55 °C
Temperatue class to EN 60079-0		T1 ... T6
EX-protection marking	Gas: Dust:	II 2G Ex db IIC T6 Gb II 2D Ex tb IIIC T.85°C Db
Nominal power consumption		10 W
Relative duty cycle		100 %
Protection class to EN 942017-2		IP 66 / 67 <small>(with properly fitted cable gland and properly made cable connection)</small>
Electrical connection		shipped without cable entry gland (1/2"NPT) and without cable. (for 105°C) <small>Cable gland must have the following certificate: Ex dbIIC / Ex tb IIIC, min. IP66/67 (according to IEC/EN 60079-14).</small>



IMPORTANT!:

1) The less favorable values from the hydraulic and electrical characteristics determine the temperature range of the whole valve.



IMPORTANT!:

2) The maximum fluid temperature must not exceed the permissible ambient temperature for the whole valve.



IMPORTANT!:

For use in the ambient temperature range -60 °C to +80 °C (T4/T135 °C) a T4 version 14 W is available on request.

3 Symbols / Spool types

4/2 functions	4/2 functions with A-solenoid	4/2 functions with B-solenoid	4/3 functions
FWKDX42A-6... 	FWKDX42AD-6... 	FWKDX42BD-6... 	FWKDX43D-6...
FWKDX42B-6... 	FWKDX42AG-6... 	FWKDX42BG-6... 	FWKDX43G-6...
FWKDX42C-6... 	FWKDX42AH-6... 	FWKDX42BH-6... 	FWKDX43H-6...
Übergangsstellungen temporary position 	FWKDX42AJ-6... 	FWKDX42BJ-6... 	FWKDX43J-6...

4 Performance graphs

measured with oil viscosity 33 mm²/s (cSt), coil at steady-state temperature and 5 % undervoltage

$\Delta p = f(Q)$ Pressure drop - Flow rate characteristic
A / B, D, G, H, and J spools up to 32 l/min

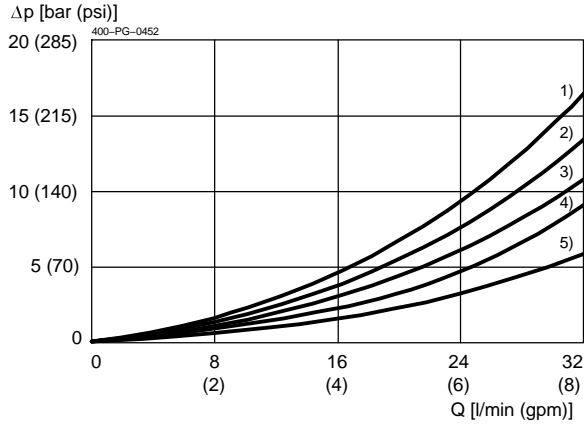

$\Delta p = f(Q)$ Pressure drop - Flow rate characteristic
C spool up to 18 l/min

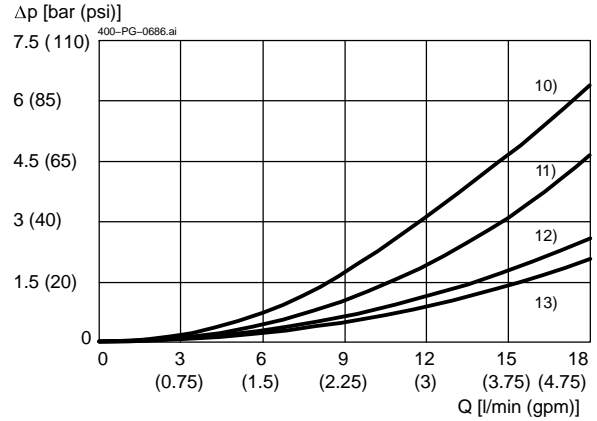

IMPORTANT!

The quoted max. flow rates apply when symmetrical flows pass through the valve.



IMPORTANT!

For non-symmetrical flows, the max. flows are substantially reduced, in worst cases to only 25 % of the above valves.

Spool type	Flow direction					
	P ⇒ A	B ⇒ T	P ⇒ B	A ⇒ T	P ⇒ T	P, A + B ⇒ T
A / B	5	4	4	2	--	--
D	4	3	4	3	--	--
G	4	5	4	5	--	--
H	2	2	2	3	--	4
J	3	1	3	1	4	--
C	11	10	13	12		--

5 Dimensions & sectional view

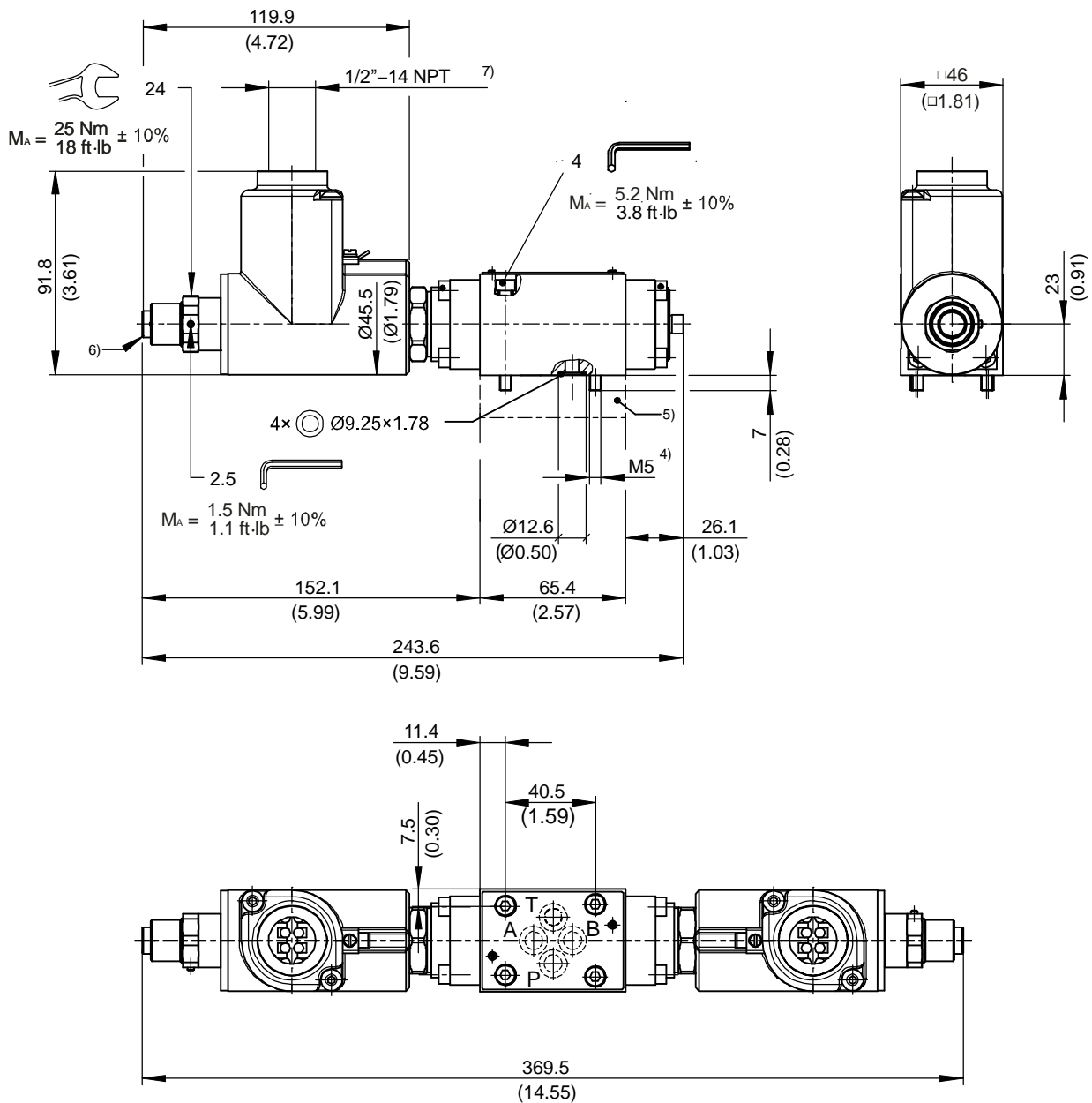

IMPORTANT!:

- 4) valve mounting bolts M5X45 (included in the delivery)
- 5) stack mounting spacer plate SZ-16-6 must be ordered separately.
- 6) manual override (on each solenoid)
- 7) cable gland with thread 1/2" NPT, must be ordered separately
- 8) 4/2 valves (1 solenoid)
- 9) 4/3 valves + 4/2 valves detent (2 solenoids)

6 Installation information

COMMISSIONING

- The solenoid coils must only be operated when they are fitted on the associated valve. For more information on installation and commissioning, please refer to the operating instructions supplied with the solenoid coil.



ATTENTION!

Ratings given in the operating instructions
Pay attention to the relevant operating instructions from the solenoid coil! If in doubt, the less favorable values apply.



ATTENTION!

Authorized persons

The tasks described here may only be carried out by authorized personnel. Authorized personnel are those who have electro-technical training (EN 60204-1).

7 Ordering code

	Ex.	F	W	K	D	X	42	A	-	6	-	N	A	1	24	-	-
F	=	flange manifold-mounting design															
W	=	directional function															
K	=	spool-type															
D	=	direct acting															
X	=	Ex-protected coil															
42	=	4-way/2-position															
43	=	4-way/3-position															
A	=	4/2 function, solenoid at a end															
B	=	4/2 function, solenoid at b end															
C	=	4/2 function, solenoid at both ends (detented model)															
AD, AG, AH oder AJ	=	4/2 function with 4/3 spool, solenoid at a end															
BD, BG, BH oder BJ	=	4/2 function with 4/3 spool, solenoid at b end															
D, G, H, J	=	4/3 function															
6	=	nominal size 6															
N	=	NBR (nitril-butadien-rubber / BUNA) seals (<i>standard</i>)															
V	=	FKM (fluorocarbon rubber / VITON) seals (<i>special seals – please consult BUCHER</i>)															
A ... Q	=	standard model - see relevant data sheets															
Z ... R	=	special features - please consult BUCHER															
1 ... 9	=	design number (omit when ordering)															
...	=	voltage e.g. 24 (24 V)															
D	=	current DC															
A	=	current AC															
10WT6	=	10W coil capacity / T6 Ex-protection temperature class															
14WT4	=	14W coil capacity / T4 Ex-protection temperature class (on request)															



IMPORTANT!:

For use in the ambient temperature range -60 °C to +80 °C (T4/T135 °C) a T4 version 14 W is available on request.

8 Related data sheets

Reference	(Old no.)	Description
400-P-030501	(i-31)	Size 03 interface to ISO 4401-03-02
SN/455GD		Safety note coils type 455GD...
400-P-010101		MTTF _D Values for Hydraulic Valves

info.ch@bucherhydraulics.com

www.bucherhydraulics.com

© 2024 by Bucher Hydraulics AG Frutigen, CH-3714 Frutigen

All rights reserved.

Data is provided for the purpose of product description only, and must not be construed as warranted characteristics in the legal sense. The information does not relieve users from the duty of conducting their own evaluations and tests. Because the products are subject to continual improvement, we reserve the right to amend the product specifications contained in this catalogue.

Classification: 430.300.-.305.310.300