

Directional valve 2-way/2-position

$Q_{\max} = 36 \text{ gpm}$, $p_{\max} = 5000 \text{ psi}$
switching solenoid, pilot operated, poppet type
Type series: WRV_22O-10A-_A...

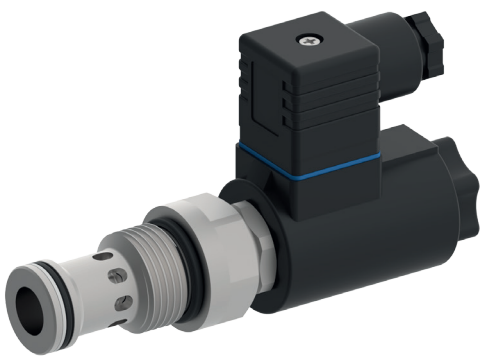

- Screw-in cartridge valve
- For cavity HA/C1220
- All external parts with zinc-nickel plating according to DIN EN ISO 19598
- Fits common cavity according to ISO
- Reliable switching, even after long dwell times
- Seat tight shut-off
- Optional with manual override
- Installation in threaded port body type GHA-34
- The slip-on coil can be rotated, and it can be replaced without opening the hydraulic envelope
- High pressure wet-armature solenoids
- Various plug-connector systems and voltages are available

Description

The 2-way/2-position solenoid operated directional seat valves, series WRV_22O-10A..., are size 10 / SAE 12, two stage, pressure balanced screw-in valves with a 1 1/16-12 UN mounting thread. They are designed on the poppet/seat principle, and the 2 to 1 flow path is therefore virtually leak-free. "De-energized open" function is available. The straightforward design delivers a good price/performance ratio and outstanding headloss/flow ratings. These valves are used in mobile and industrial applications where leak-tight shut-off

functions are crucially important. Examples are where loads, tensions, or clamping forces must be held without leakage. All external parts of the screw-in valves are zinc-nickel plated and are thus suitable for use in the harshest operating environments. The slip-on coils can be replaced without opening the hydraulic envelope and can be positioned at any angle through 360°. For self-assembly, please refer to the section related data sheets.

Symbol

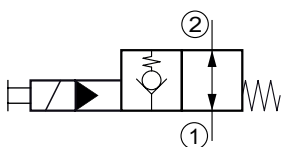

Technical data

General characteristics	Description, value, unit
Function group	Directional valve
Function	2-way/2-position
Design	Screw-in cartridge valve
Controls	switching solenoid
Characteristic	pilot operated, poppet type
MTTFd value	150 years
Construction size	NG 10 / SAE 12
Thread size	1 1/16-12 UN-2A
Mounting attitude	unrestricted
Weight	1.30 lb
Cavity acc. ISO	fits into ISO 17209: 1 1/16-01-1-13
Cavity acc. factory standard	For cavity HA/C1220
Tightening torque steel	110 ft·lb
Tightening torque aluminium	110 ft·lb
Tightening torque tolerance	± 10 %
Minimum ambient temperature	- 13 °F
Maximum ambient temperature	+ 122 °F
Surface protection	All external parts with zinc-nickel plating according to DIN EN ISO 19598
Sealing material	see ordering code
Seal kit order number	NBR: DS-505-N / FKM: DS-505-V

Hydraulic characteristics	Description, value, unit
Maximum operating pressure	5000 psi
Maximum flow rate	36 gpm
Flow direction	see symbol
Hydraulic fluid	HL and HLP mineral oil according to DIN 51 524; other fluids on request!
Minimum fluid temperature	- 13 °F
Maximum fluid temperature	+ 176 °F
Viscosity range	10 ... 500 mm ² /s (cSt)
Recommended viscosity range	15 ... 250 mm ² /s (cSt)
Minimum fluid cleanliness (cleanliness class according to ISO 4406:1999)	class 20/18/15

NOTE!

The switching safety of the valve is achieved by the volume flow and pressure drop (Δp).

Electric characteristics	Description, value, unit
Actuator type	solenoid coil
Solenoid coils type	D36
Supply voltage DC	12/24 V DC
Supply voltage AC	115/230 (50 ... 60 Hz) V AC
Supply voltage tolerance	± 10 %
Nominal power consumption	Version "E": V DC = 17 W / V AC = 17 W Version "N": V DC = 27 W / V AC = 25 W
Switching time	Switching time measured at: U_N ; $\Delta p = 300 \text{ bar}$; $Q = 80 \text{ l/min}$; $T_{\text{Ambient}} = 20 \text{ °C}$; $\varnothing = 46 \text{ mm}^2/\text{s}$ WRVE: 74 ms (energizing) 93 ms (de-energizing) WRVN: 58 ms (energizing) 90 ms (de-energizing)
Relative duty cycle	100 %
Electrical connection coil	several connection types available, see ordering code
Protection class solenoid coil to ISO 20 653 / EN 60 529	several classes of protection available, see ordering code (with appropriate mating connector and proper fitting and sealing)



NOTE!

The switching time can be strongly dependent on flow rate, pressure, oil viscosity and the dwell time under pressure. In practice, the switching time may therefore deviate from the specified value range.

Performance graphs

measured with oil viscosity 33.0 mm²/s (cSt), coil at steady-state temperature and 10 % undervoltage

$p = f(Q)$ Performance limit

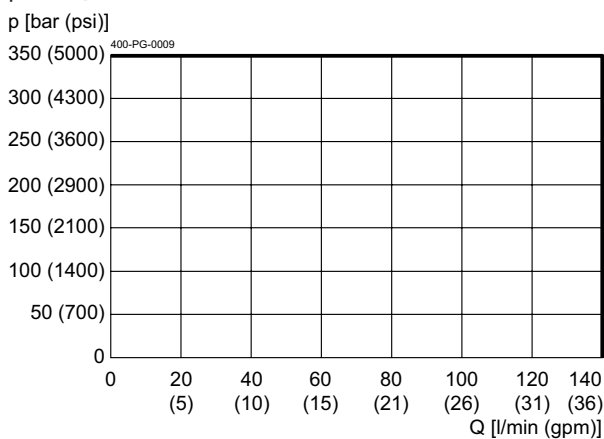

$\Delta p = f(Q)$ Pressure drop-flow rate characteristic

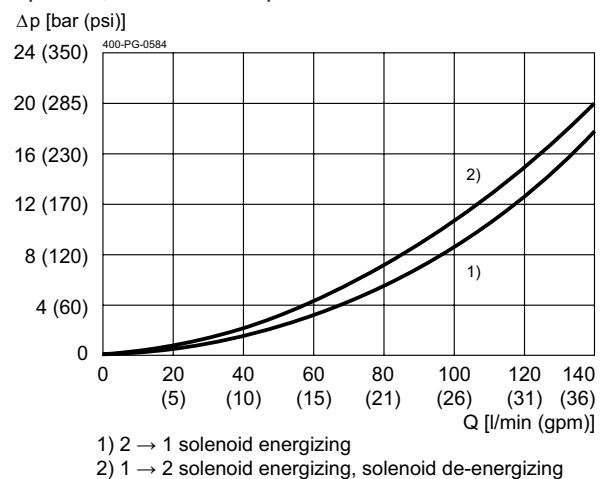

Dimensions and sectional view

Beispiel für die Masseinheit:
Example for the dimensional units:
0.79 = 0.79 mm millimeter
(.031) = 0.031" inch

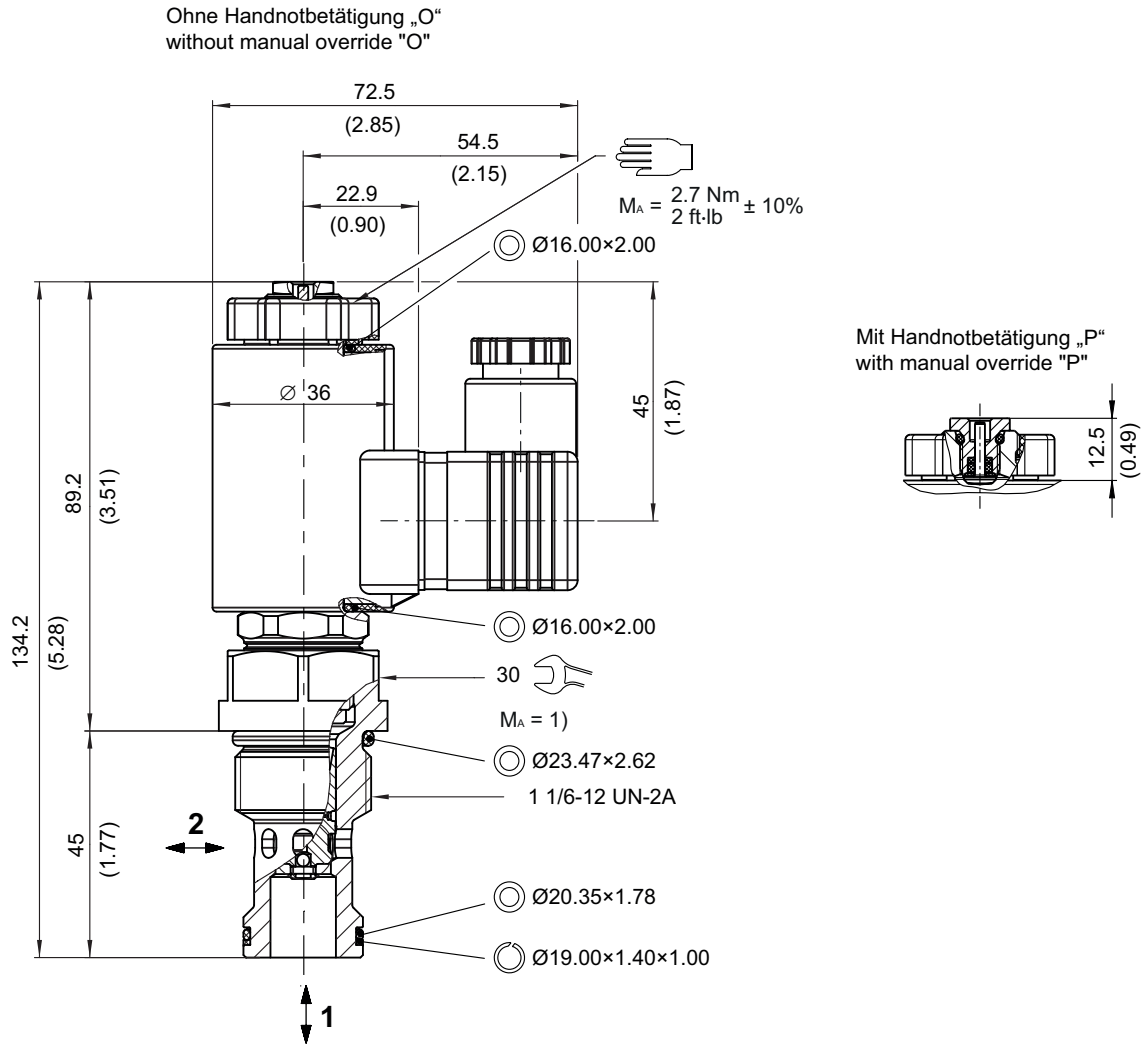

Installation information



IMPORTANT!

When fitting the screw-in valves, use the specified tightening torque. No adjustments are necessary, since the valves are set in the factory.



ATTENTION!

Only qualified personnel with mechanical skills may carry out any maintenance work. Generally, the only work that should ever be undertaken is to check, and possibly replace, the seals. When changing seals, oil or grease the new seals thoroughly before fitting them.

Ordering code

Ex.

W	R	V	_	22O	-	10	A	-	_	-	N	A	1	24	_	_
---	---	---	---	-----	---	----	---	---	---	---	---	---	---	----	---	---

- W = directional valve
 - R = check valve function, seated design
 - V = pilot operated
 - E = elec. operated, V DC = 17 W / V AC = 17 W **(standard)**
 - N = electrically operated, V DC = 27 W / V AC = 25 W
 - 22O = 2-way/2-position, normally open
 - 10 = nominal size 10 / SAE 12
 - A = cavity type HA/C1220
 - O = without manual override
 - P = with manual override
 - N = NBR (Nitrile) seals **(standard)**
 - V = FKM (Viton) seals
(special seals - please contact BUCHER)
 - A ... Q = standard model according to valid data sheet
 - Z ... R = special model after consultation
 - 1 ... 9 = technical design no. (omit when ordering)
 - ... = voltage e. g. 24 (24 V)
 - D = current DC
 - A = current AC
 - Ohne = DIN EN 175301-803 connection with mating plug **(standard, IP 65)**
 - M100 = DIN EN 175301-803 connection without mating plug
 - C = Kostal plug connection (IP 65)
 - JT = Junior Timer radial plug connection (with protection diode, IP 65)
 - IT = Junior Timer axial plug connection (with protection diode, IP 65)
 - D = Deutsch plug connection 45° DT04-2P (IP 67/69K)
 - DT = Deutsch plug connection 45° DT04-2P (with protection diode, IP 67/69K)
 - S = AMP Superseal 1.5 (IP 67) / Metri-Pack 150 (IP 65) plug connection
 - F = flying leads (500 mm)
- mating plug not supplied

Related data sheets

Reference	Description
400-P-040011	Form tools
400-P-120110	Solenoid coil D36
400-P-065101	Cavity HA/C1220
400-P-740501	Threaded port body GHA-34...
400-P-010101	MTTFD Values for Hydraulic Valves

info.ch@bucherhydraulics.com

www.bucherhydraulics.com

© 2024 by Bucher Hydraulics AG Frutigen, 3714 Frutigen, Switzerland

All rights reserved.

Data is provided for the purpose of product description only, and must not be construed as warranted characteristics in the legal sense. The information does not relieve users from the duty of conducting their own evaluations and tests. Because the products are subject to continual improvement, we reserve the right to amend the product specifications contained in this catalogue.