

Directional valve 2-way/2-position

$Q_{\max} = 10 \text{ gpm}$, $p_{\max} = 4500 \text{ psi}$

direct acting, poppet type, pneumatical operation

Type series: W1Q_B...

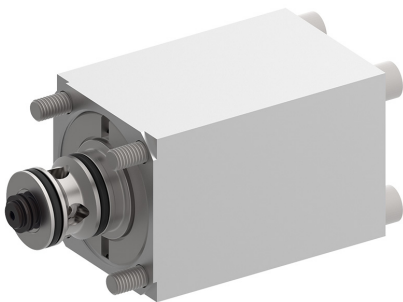

- Slip-in cartridge valve
- For cavity AA
- All external parts with zinc-nickel plating according to DIN EN ISO 19598
- Guided valve spool and poppet
- With bidirectional seat-valve shut-off
- Control head is hard-anodized aluminium
- Closed in the non-operated condition

Description

The 2-way/2-position directional seat valves, series W1Q..., are size 6, pneumatically operated, direct acting, pressure balanced, push-in valves. In the normal condition (non-operated), flow is shut off without leakage. They are designed on the tried and tested principle of the guided poppet, and the guide spool has a seal. The pneumatic control head has a G1/8" threaded port for the air feed. All external parts of cartridge are zinc-nickel plated, the aluminum control head is

hard-anodized, and the valve is thus suitable for use in the harshest operating environments. These valves are predominantly used in certain mobile and industrial applications where leak-tight shut-off functions are crucially important. Examples are where loads, tensions, or clamping forces must be held without leakage. For self-assembly, please refer to the section related data sheets.

Symbol

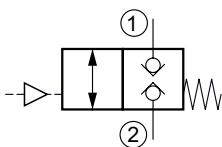

Technical data

General characteristics	Description, value, unit
Function group	Directional valve
Function	2-way/2-position
Design	Slip-in cartridge valve
Controls	pneumatical operation
Characteristic	direct acting, poppet type
Construction size	nominal size 6
Mounting attitude	unrestricted
Weight	1 lbs
Cavity acc. factory standard	For cavity AA
Tightening torque steel	4 ft·lb
Tightening torque aluminium	4 ft·lb
Tightening torque tolerance	± 5 %
Minimum ambient temperature	- 13 °F
Maximum ambient temperature	+ 176 °F
Surface protection	All external parts with zinc-nickel plating according to DIN EN ISO 19598
Sealing material	see ordering code
Seal kit order number	NBR: DS-095-N / FKM: DS-095-V

Hydraulic characteristics	Description, value, unit
Maximum operating pressure	4500 psi
Maximum flow rate	10 gpm
Flow direction	see symbol
Hydraulic fluid	HL and HLP mineral oil according to DIN 51 524; other fluids on request!
Minimum fluid temperature	- 13 °F
Maximum fluid temperature	+ 176 °F
Viscosity range	10 ... 650 mm ² /s (cSt)
Recommended viscosity range	15 ... 250 mm ² /s (cSt)
Minimum fluid cleanliness (cleanliness class according to ISO 4406:1999)	class 20/18/15
Pilot operating media	compressed air
Pilot pressure	min. 90 psi

Performance graphs

measured with oil viscosity 33.0 mm²/s (cSt)

$p = f(Q)$ Performance limit

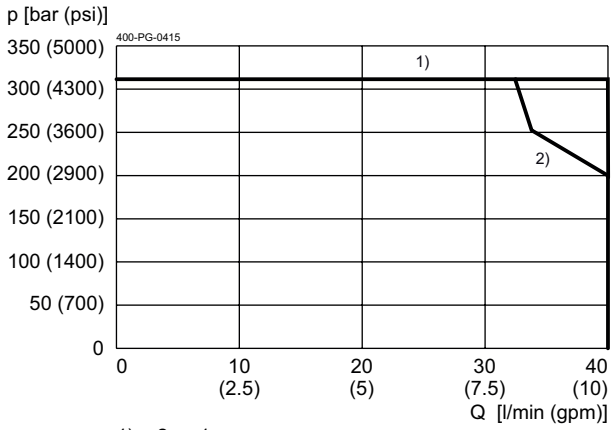

1) = 2 → 1
2) = 1 → 2

$\Delta p = f(Q)$ Pressure drop-flow rate characteristic

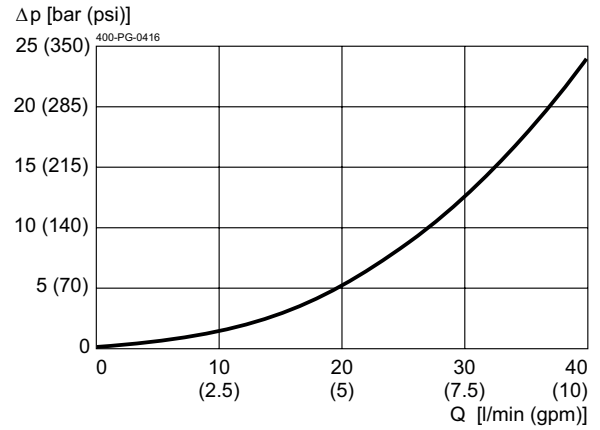

Dimensions and sectional view

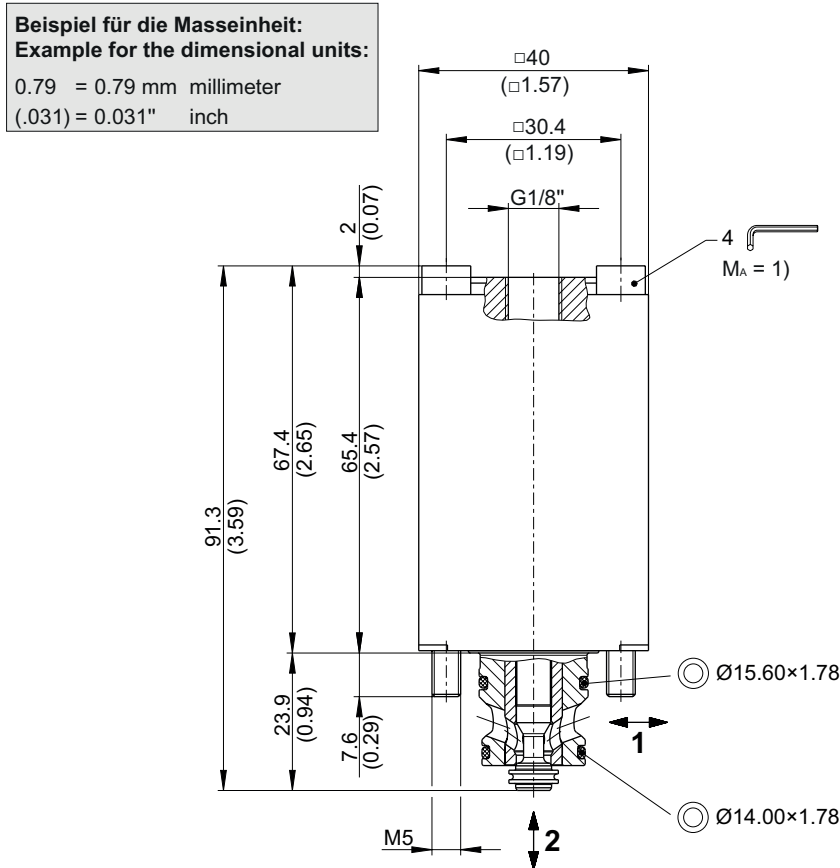

Installation information



ATTENTION!

Only qualified personnel with mechanical skills may carry out any maintenance work. Generally, the only work that should ever be undertaken is to check, and possibly replace, the seals. When changing seals, oil or grease the new seals thoroughly before fitting them.



NOTE!

1) When fitting the slip-in valves, use the specified tightening torque for the mounting screws. The value can be found in the chapter "Technical data".



IMPORTANT!

These valves can also be fitted in the cavity AC according to factory standard, and in such cases port 3 then has the same function as port 2.

Ordering code

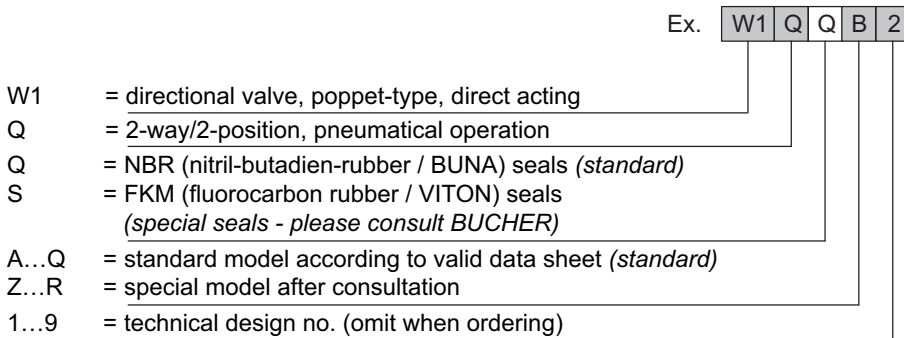

Related data sheets

Reference	Description
400-P-040011	Form tools
400-P-040101	Cavity AA