

Directional valve 2-way/2-position

$Q_{\max} = 10 \text{ gpm}$, $p_{\max} = 4500 \text{ psi}$
switching solenoid, direct acting, poppet type
Type series: W1C_B... (installation deep)



- Slip-in cartridge valve
- For cavity AB
- All external parts with zinc-nickel plating according to DIN EN ISO 19598
- Guided valve spool and poppet
- With bidirectional seat-valve shut-off
- With or without manual override
- De-energized closed
- As an option, hand lever can be fitted to solenoid The slip-on coil can be rotated, and it can be replaced without opening the hydraulic envelope
- High pressure wet-armature solenoids
- Various plug-connector systems and voltages are available

Description

The 2-way/2-position solenoid operated directional seat valves, series W1C_B (installation deep), are size 6, direct acting, pressure balanced, push-in valves. They are designed on the poppet/seat principle and are leak-tight in both flow directions (bidirectional seat-valve shut-off). The guide spool has a seal. This version is the mounting version "deep" which fits into the cavity AB according to factory standard. See separate data sheet for the mounting version "shallow". These valves are also available with or without manual override, and with the option of an additional hand lever.

All external parts of the screw-in valves are zinc-nickel plated and are thus suitable for use in the harshest operating environments. The slip-on coils can be replaced without opening the hydraulic envelope and can be positioned at any angle through 360°. These valves are predominantly used in certain mobile and industrial applications where leak-tight shut-off functions are crucially important. Examples are where loads, tensions, or clamping forces must be held without leakage. For self-assembly, please refer to the section related data sheets.

Symbol

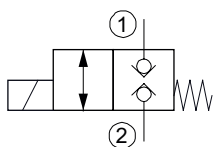

Without manual override (standard)

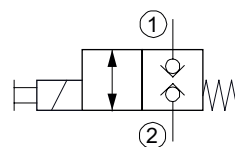

With manual override

Technical data

General characteristics	Description, value, unit
Function group	Directional valve
Function	2-way/2-position
Design	Slip-in cartridge valve
Controls	switching solenoid
Characteristic	direct acting, poppet type
MTTFd value	150 years
Construction size	NG 6
Mounting attitude	unrestricted
Weight	1.9 lbs
Cavity acc. factory standard	For cavity AB
Tightening torque steel	4 ft·lb
Tightening torque aluminium	4 ft·lb
Tightening torque tolerance	± 5 %
Minimum ambient temperature	- 13 °F
Maximum ambient temperature	+ 122 °F
Surface protection	All external parts with zinc-nickel plating according to DIN EN ISO 19598
Sealing material	see ordering code
Seal kit order number	NBR: DS-095-N / FKM: DS-095-V



IMPORTANT!

The less favorable values from the general, hydraulic and electrical characteristics determine the temperature range of the whole valve.

Hydraulic characteristics	Description, value, unit
Maximum operating pressure	4500 psi
Maximum flow rate	10 gpm
Flow direction	see symbol
Hydraulic fluid	HL and HLP mineral oil according to DIN 51 524; other fluids on request!
Minimum fluid temperature	- 13 °F
Maximum fluid temperature	+ 176 °F
Viscosity range	10 ... 500 mm ² /s (cSt)
Recommended viscosity range	15 ... 250 mm ² /s (cSt)
Minimum fluid cleanliness (cleanliness class according to ISO 4406:1999)	class 20/18/15

Electric characteristics	Description, value, unit
Actuator type	solenoid coil
Solenoid coils type	D45/207
Supply voltage DC	12/24 V DC
Supply voltage AC	115/230 (50 ... 60 Hz) V AC
Supply voltage tolerance	± 10 %
Maximum permissible power consumption	V DC = 30 ... 32 W / V AC = 31 ... 32 W
Switching time	25 ... 170 ms (energizing), 15 ... 70 ms (de-energizing)
Relative duty cycle	100 %
Electrical connection coil	several connection types available, see ordering code
Protection class solenoid coil to ISO 20 653 / EN 60 529	several classes of protection available, see ordering code (with appropriate mating connector and proper fitting and sealing)



IMPORTANT!

To ensure the performance data is not compromised, it is imperative to use coils D45/207 according to data sheet 400-P-120120.



NOTE!

These times are strongly influenced by fluid pressure, flow rate and viscosity, as well as by the dwell time under pressure.

Performance graphs

measured with oil viscosity 33.0 mm²/s (cSt), coil at steady-state temperature and 10 % undervoltage

$p = f(Q)$ Performance limit

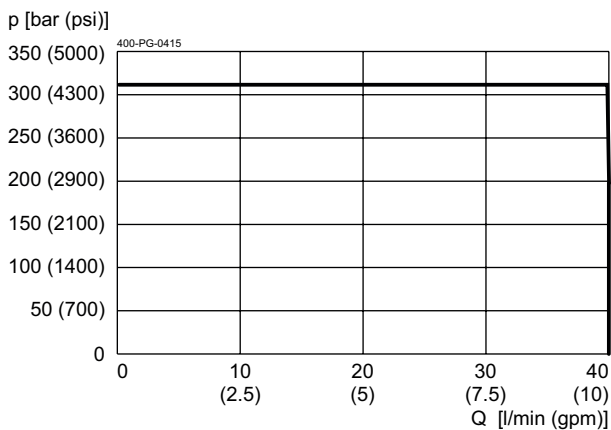

$\Delta p = f(Q)$ Pressure drop-flow rate characteristic

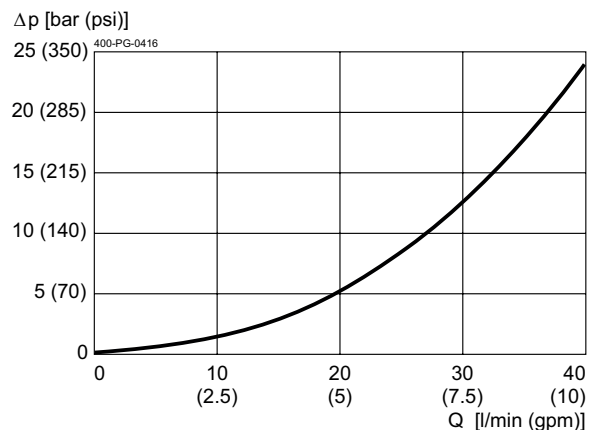

Dimensions and sectional view

Beispiel für die Masseinheit:
Example for the dimensional units:
0.79 = 0.79 mm millimeter
(.031) = 0.031" inch

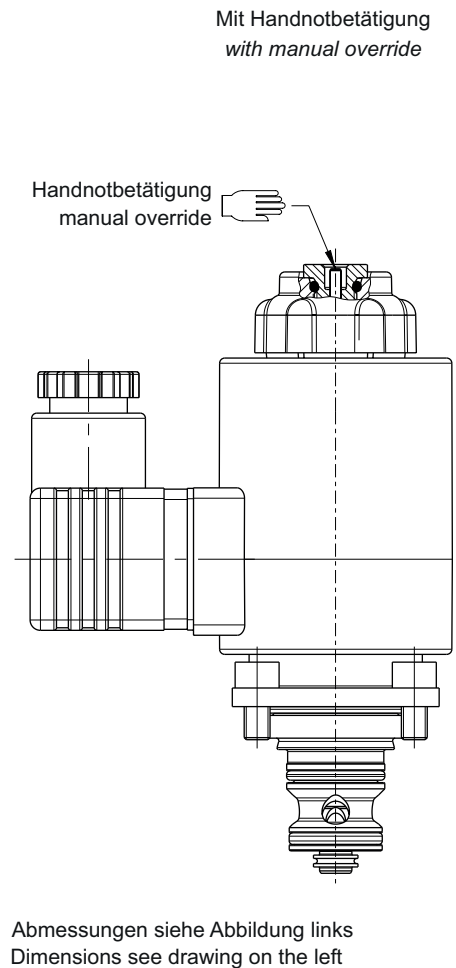
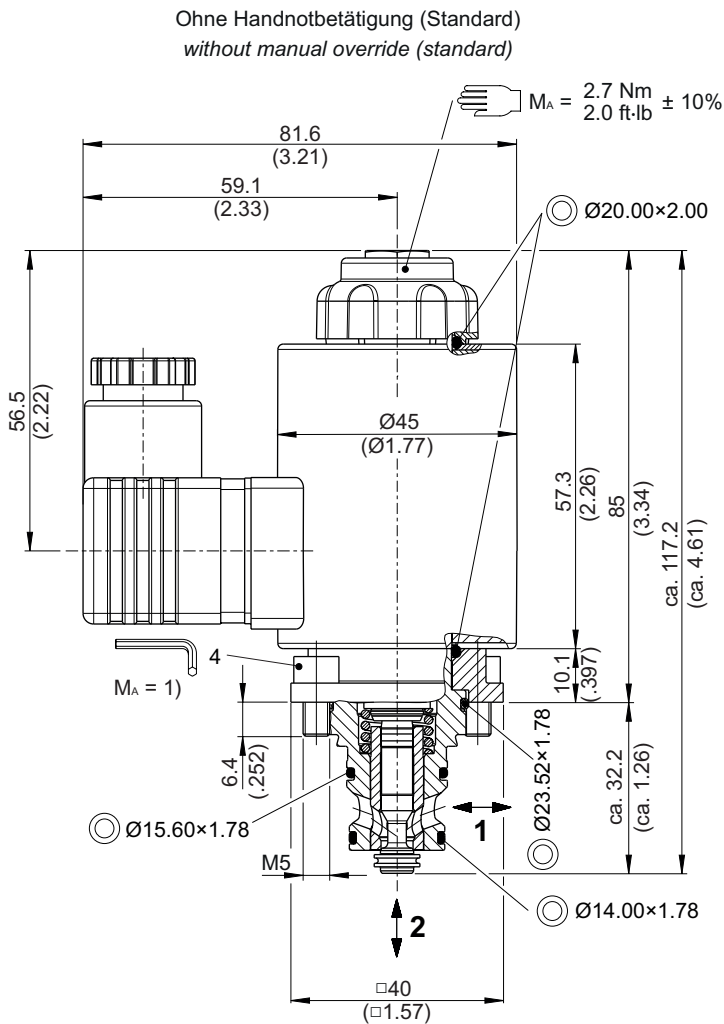

Installation information



ATTENTION!

Only qualified personnel with mechanical skills may carry out any maintenance work. Generally, the only work that should ever be undertaken is to check, and possibly replace, the seals. When changing seals, oil or grease the new seals thoroughly before fitting them.



NOTE!

1) When fitting the slip-in valves, use the specified tightening torque for the mounting screws. The value can be found in the chapter "Technical data".

i NOTE! These valves can also be fitted in the cavity AD according to factory standard, and in such cases port 3 then has the same function as port 2.

i IMPORTANT! A “de-energized open” function can be created by using the 3/2 solenoid cartridge valve and the GADA line-mounting body. In this case, ports 2 and 3 are used. Port 1 is plugged.

i IMPORTANT! When replacing an old coil with connection according to DIN 43650/ISO4400 (with other Pin setup than according to datasheet 400-P-120120), the new coil can be mounted in 180° reversed position so that the existing plug (with 180° earthingPIN) can be connected. This does not affect the performance data.

Hand lever fitted on solenoid (optional)

Beispiel für die Masseinheit:
Example for the dimensional units:
 0.79 = 0.79 mm millimeter
 (.031) = 0.031" inch

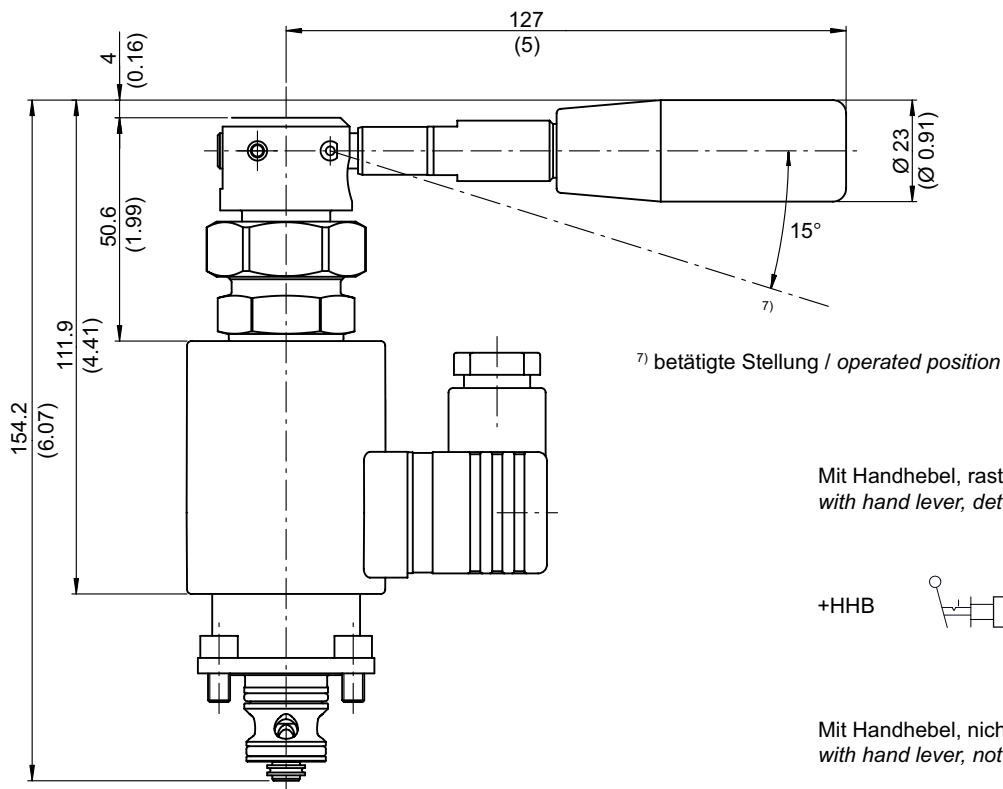

Mit Handhebel, rastbar
 with hand lever, detentable

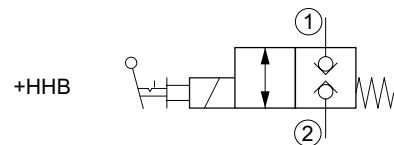

Mit Handhebel, nicht rastbar
 with hand lever, not detentable

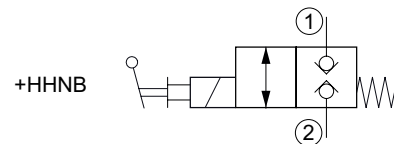

As an option, these valves are available with an additional hand lever. The hand lever can be fitted on the solenoid. Two models can be supplied: “HHB” hand lever with detent feature, and the “HHNB” hand lever without detent feature.

i IMPORTANT! Hand levers can only be fitted to valves that have a manual override.

Ordering code

Ex.

W1	C	E	B	3	24	D	_	+HHB	-	2
----	---	---	---	---	----	---	---	------	---	---

- W1 = directional valve, poppet-type, direct acting
- C = 2-way/2-position, de-energized closed
- E = without manual override, with NBR (BUNA) seals **(standard)**
- K = without manual override, with FKM (VITON) seals
- C = with manual override, with NBR (BUNA) seals
- H = with manual override, with FKM (VITON) seals
- A...Q = standard model according to valid data sheet **(standard)**
- Z...R = special model after consultation
- 1...9 = technical design no. directional valve (omit when ordering)
- ... = voltage e.g. 24 (24 V)
- D = current DC
- A = current AC
- (blank) = DIN EN 175301-803 connection, 3-pole 2 P+E with mating plug, IP 65 **(standard)**
- M100 = DIN EN 175301-803 connection, 3-pole 2 P+E
- DT = Deutsch plug connection DT04-2P (with protection diode, IP 67/69K)
- JT = Junior Timer radial plug connection (with protection diode, IP 65)
- F = flying leads (600 mm)
- (blank) = without hand lever *(standard)*
- +HHB = with hand lever, detentable
- +HHNB = with hand lever, not detentable
- 1...9 = technical design no. hand lever (omit when ordering)

} mating plug not supplied

Related data sheets

Reference	Description
400-P-040011	Form tools
400-P-120120	Solenoid coil D45/207
400-P-040102	Cavity AB
400-P-730111	Threaded port body GABA
400-P-730121	Threaded port body GADA
400-P-010101	MTTFD Values for Hydraulic Valves