

# Bypass Compensator Cartridge, Size 16

$Q_{\max} = 350 \text{ l/min}$ ,  $p_{\max} = 420 \text{ bar}$   
Direct acting, adjustable compensator spring  
Series DWDPA-2B...



- Compensator spring adjustable from 5...13 bar
- External remote-control port 3 with integral damping orifice
- High flow rates
- Excellent stability over the whole pressure and flow range
- Available with hand-knob or tamper-proof cap
- All exposed parts with zinc-nickel plating
- Can be fitted in a line-mounting body

## 1 Description

These direct-acting bypass pressure-compensator (hydrostat) cartridges, series DWDPA-2B...-16..., are size 16, high performance screw-in cartridges with an M42x2 mounting thread. The main stage is designed on the sliding-spool principle, and it can be set between 5...13 bar using the adjustable compensator spring. Pressure-compensator cartridges maintain the control pressure difference between inlet and outlet pressure - for example, across a throttle (an orifice) - at a constant level. This means that the flow rate is independent of the load pressure at the actuator. The adjusting screw or the hand-knob enable the user to carry out system optimisation directly on the equipment, without any need to install or replace components that have different flow ranges (e.g.

proportional valves). To safeguard valve settings, the adjusting screw can be sealed with a tamper-proof cap. By fitting external pilot controls (pressure-relief valves or 2/2 unloading valves) in the line to the port 3, additional functions such as pressure relief or vented bypass from 1 → 2 can be produced. These screw-in cartridges are used in hydraulic circuits in mobile and industrial applications, predominantly in conjunction with a throttle cartridge. All external parts of the cartridge are zinc-nickel plated to DIN 50 979 and are thus suitable for use in the harshest operating environments. If you intend to manufacture your own cavities or are designing a line-mounting installation, please refer to the section "Related data sheets".

## 2 Symbol

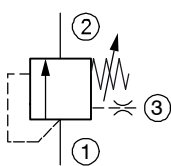

## 3 Technical data

General characteristics	Description, value, unit
Designation	bypass pressure-compensator cartridge
Design	direct acting, adjustable compensator spring, external remote-control port 3 with integral damping orifice
Mounting method	screw-in cartridge M42x2
Tightening torque	200 Nm ± 10 %
Size	nominal size 16, cavity type EB to ISO 7789-42-06-0-07
Weight	0.92 kg
Mounting attitude	unrestricted
Ambient temperature range	-25 °C ... +80 °C

Hydraulic characteristics	Description, value, unit
Maximum operating pressure	420 bar
Maximum allowable pressure in port 3	420 bar
Maximum flow rate 1 → 2	350 l/min
Maximum flow rate attainable at the actuator	210 l/min with control $\Delta p$ of 5 bar 315 l/min with control $\Delta p$ of 13 bar
Pressure adjustment range	5...13 bar (1 turn $\approx$ 1.2 bar)
Flow direction	1 → 2, see symbols
Hydraulic fluid	HL and HLP mineral oil to DIN 51 524; for other fluids, please contact BUCHER
Hydraulic fluid temperature range	-25 °C ... +80 °C
Viscosity range	10...650 mm <sup>2</sup> /s (cSt), recommended 15...250 mm <sup>2</sup> /s (cSt)
Minimum fluid cleanliness Cleanliness class to ISO 4406 : 1999	class 20/18/15

## 4 Performance graphs

measured with oil viscosity 33 mm<sup>2</sup>/s (cSt) and in a cavity with an annular groove

Test setup (for flow rate v. load pressure characteristic)

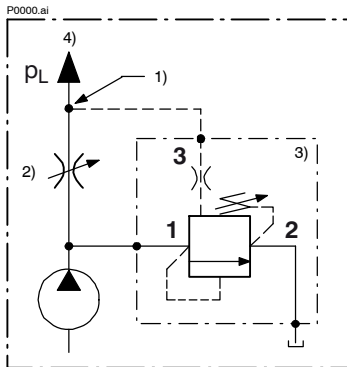

- 1) Load sensing immediately after orifice 2)
- 2) Throttle function (orifice size, see performance graphs)
- 3) Bypass pressure-compensator cartridge
- 4) Actuator port ( $p_L = \text{load pressure}$ )



### IMPORTANT!

The load sensing and compensator inlet (port 1) tapping points must be located **immediately after the throttle (orifice) and before it respectively**. This minimises the pressure drop and gives the best flow rate / load pressure values.



### IMPORTANT!

All characteristics were recorded with a surplus flow of 10...15 l/min.

$Q = f(p_L)$  Flow rate v. load pressure characteristic at the minimum compensator setting (5 bar)

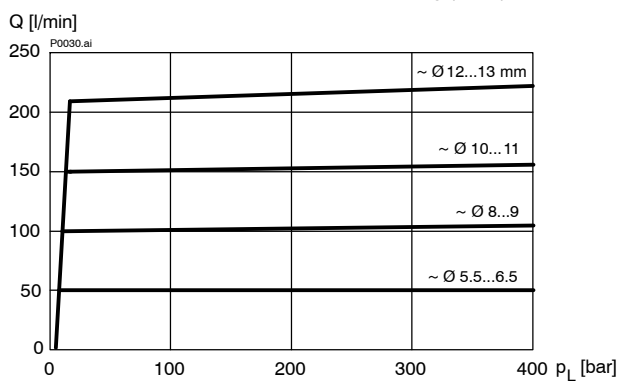

$Q = f(p_L)$  Flow rate v. load pressure characteristic at the maximum compensator setting (13 bar)

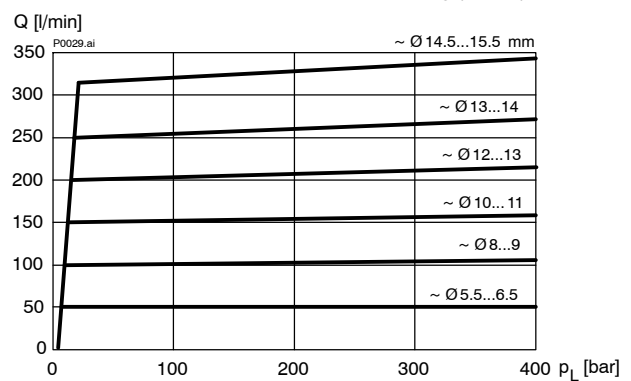

$\Delta p = f(Q)$  Pressure-drop characteristic (control  $\Delta p$ , 1→2) (port 3 completely unloaded)

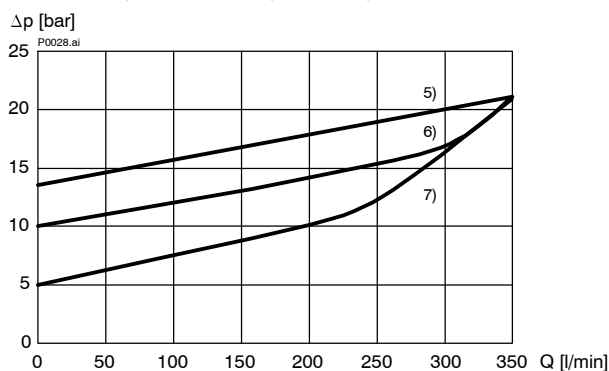

- 5) 13 bar control  $\Delta p$  setting (maximum value)
- 6) 10 bar control  $\Delta p$  setting (mid-range value)
- 7) 5 bar control  $\Delta p$  setting (minimum value)

## 5 Dimensions & sectional view

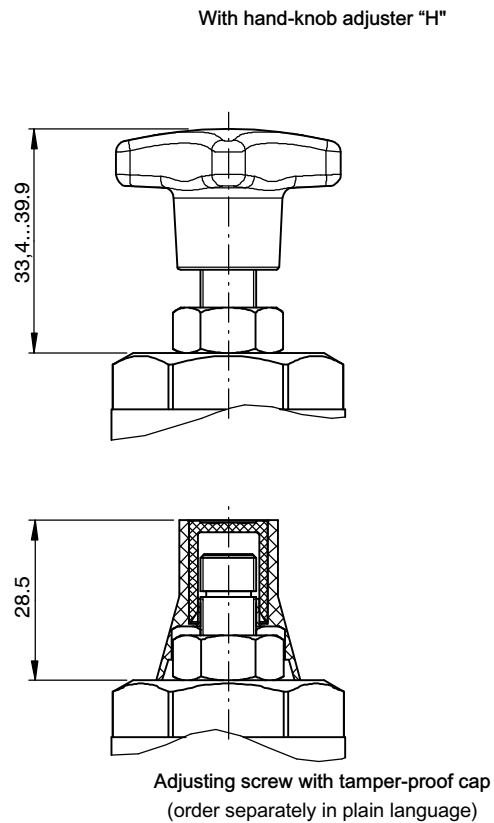
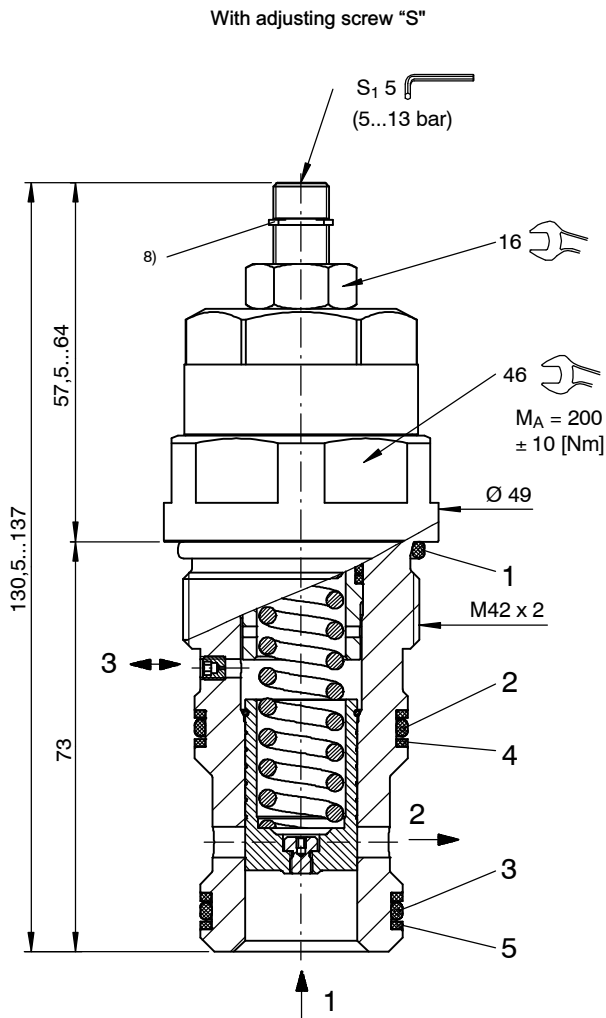

## 6 Installation information



### IMPORTANT!

When fitting the cartridges, use the specified tightening torque. Set the required control  $\Delta p$  (5...13 bar) with the adjusting screw (S<sub>1</sub> 5). After you have set the valve, lock the adjusting screw with the lock nut.



### ATTENTION!

Only qualified personnel with mechanical skills may carry out any maintenance work. Generally, the only work that should ever be undertaken is to check, and possibly replace, the seals. When changing seals, oil or grease the new seals thoroughly before fitting them.



### IMPORTANT!

Valve settings can be sealed by fitting the tamper-proof cap. To fit the cap, the snap ring <sup>8)</sup> has to be removed. Subsequent adjustment is only possible by destroying the tamper-proof cap.

### Seal kit NBR no. DS-359-N <sup>9)</sup>

Item	Qty.	Description
1	1	O-ring no. 129 Ø 39,34 x 2,62 N90
2	1	O-ring no. 125 Ø 32,99 x 2,62 N90
3	1	O-ring no. 124 Ø 31,42 x 2,62 N90
4	2	Backup ring Ø 32,00 x 2,00 x 1,40 FI0751
5	2	Backup ring Ø 30,00 x 2,00 x 1,40 FI0751



### IMPORTANT!

<sup>9)</sup> Seal kit with FKM (Viton) seals, no. DS-359-V

## 7 Application examples

The following diagram shows a typical manifold block that uses our direct acting, bypass pressure-compensator cartridges. Because the port can be pressurised by the returning oil, priority and series circuits can be constructed. If the direct acting bypass compensator (BDWD1) does not receive a load signal from the shuttle valve (WV), it forwards the oil flow to the next actuator with a pressure drop that, at its maximum, is equal to the control  $\Delta p$  (5...13 bar) that has been set.

If the 4/3 proportional directional valve (4/3-PW) is now operated, the inline compensator (IDW) ensures load-independent travel at a speed that is determined by the 4/3 proportional directional valve. A maximum pressure can be set with the proportional pressure-relief pilot valve (ePD). The direct acting bypass compensator (BDWD1) ensures that the 4/3 proportional directional valve (4/3-PW) is

supplied with the oil flow rate that it requires, regardless of the other actuators. The surplus flow is made available to the other actuators. If the ventable proportional throttles (PD1 and PD2) are not operated, the flow is routed to tank through the bypass compensators (BDWD2 and BDWD3). If the proportional throttles (PD1 and/or PD2) are activated, the hydraulic motors (Motor 1 and/or Motor 2) rotate at speeds that are independent of their loads. The speed is determined by the respective proportional throttle. The direction of rotation of Motor 1 can be reversed by operating the 4/2 directional valve (4/2-WV). The hydraulic motors (Motor 1 and Motor 2) work in a series mode in which either or both can be switched on, and their speeds can be set individually at any required level and will be independent of load.

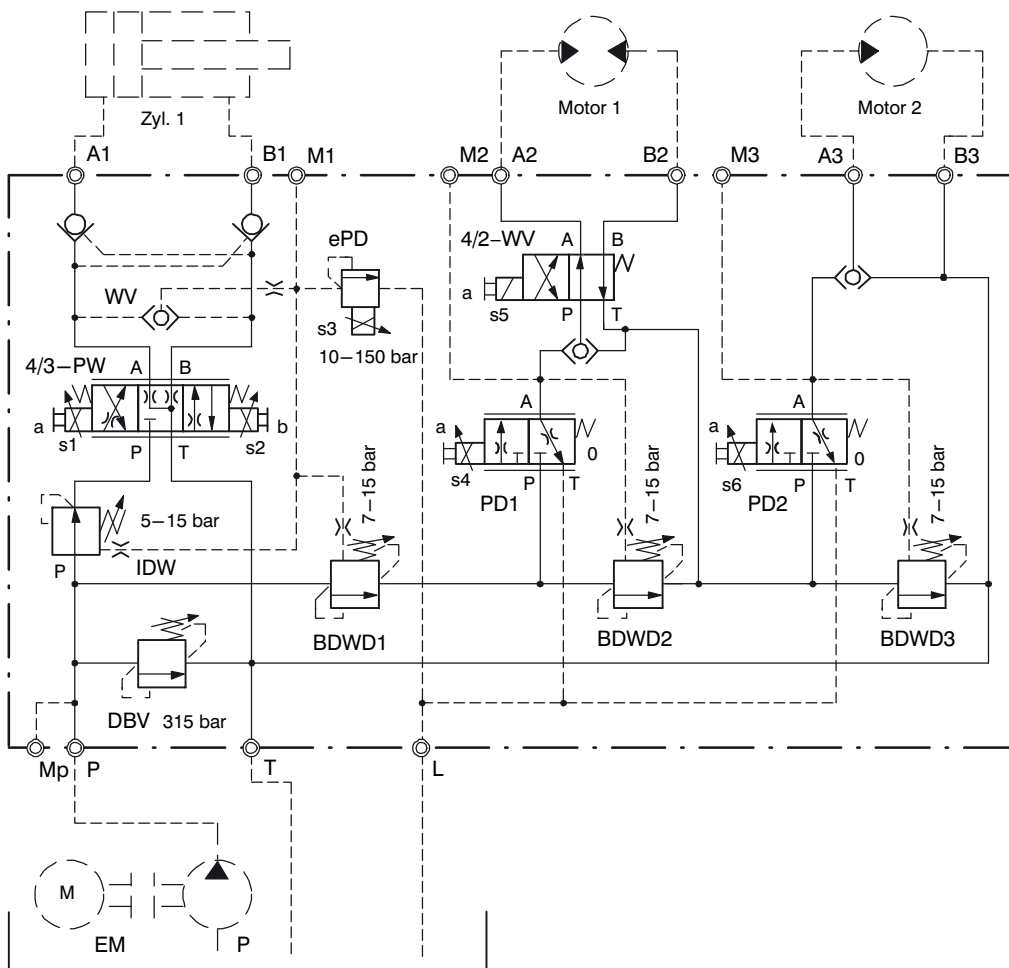

### 8 Ordering code

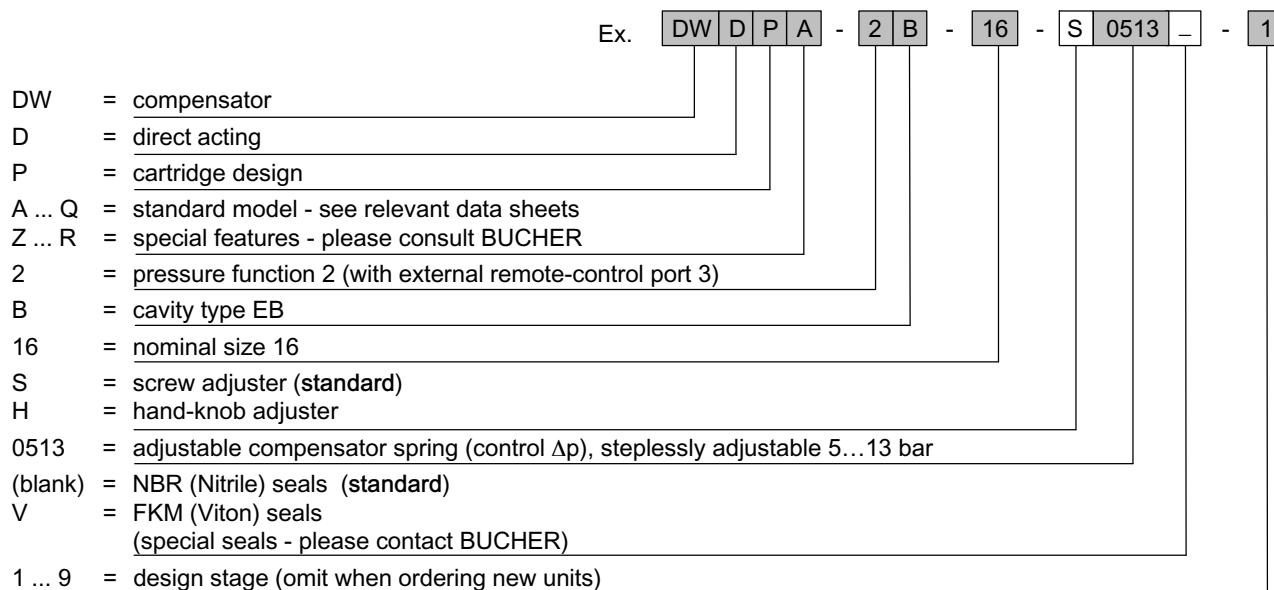

#### IMPORTANT!

When required, the tamper-proof cap (the adjustment seal) must be ordered separately in plain language.

### 9 Related data sheets

Reference	(Old no.)	Description
400-P-040011	(i-32)	The form-tool hire programme
400-P-080111	(i-55.2)	Cavity type EB to ISO 7789-42-06-0-07
400-P-750115	(G-29.22)	Line-mounting body, type GEBAA (G 1")

info.ch@bucherhydraulics.com

www.bucherhydraulics.com

© 2015 by Bucher Hydraulics AG Frutigen, CH-3714 Frutigen

All rights reserved.

Data is provided for the purpose of product description only, and must not be construed as warranted characteristics in the legal sense. The information does not relieve users from the duty of conducting their own evaluations and tests. Because the products are subject to continual improvement, we reserve the right to amend the product specifications contained in this catalogue.

Classification: 430.305.320.305.330.355