

Pumps, Valves, Power Packs, Cylinders and Manifold Blocks

Wind Turbines

Innovation and High Performance

Bucher Hydraulics products are based on the very latest design and manufacturing technologies.

Bucher Hydraulics offers:

- Customised products and solutions
- Expertise and proficiency in using these products in systems for wind turbines
- High quality standards
- High standards of supply reliability and service
- Proven reliability and long life



Supply and Development Partner

Mankind has been making use of wind power for thousands of years.

Once electricity was discovered and the generator invented it was only a short step to harnessing the wind to generate power. Existing windmill concepts were modified for this purpose and instead of transforming kinetic wind energy into mechanical energy, electrical power was produced with a generator. Since the oil crises in the nineteen seventies, research efforts have been increased world-wide to find alternative energy sources. This inevitably led to the development of today's modern wind turbines.

As one of the leading manufacturers of components such as premium pumps, valves, cylinders and power packs, Bucher Hydraulics has for decades been supplying its products to **manufacturers of hydraulic systems** for wind turbines. Our high level of competence and the great operational reliability of the individual components have proved their

worth in wind turbines world-wide. To extend its range of products, Bucher Hydraulics offers its customers complete functional modules in the form of control manifolds that can be used for the various hydraulic operations. Our mission is to offer the most demanding functions as customised designs and to be a reliable, capable partner.

We therefore impose high quality standards on ourselves – from the development phase right through to our efficient and flexible high-volume manufacturing system, we work in accordance with our ISO 9001 certification.

Bucher Hydraulics also believes in environmentally sensitive manufacturing in terms of ecology, safety and health, and commits itself to complying with the requirements of the ISO 14001 standard.



Wind turbines

The Wind Energy Challenge

Wind turbines are modern power stations. Their operations are governed by a simple principle. Wind movement is transformed into a rotary motion by means of rotor blades and converted into an electrical current by means of a generator.

Demands on hydraulics

Today's technology has reached such a high quality level that wind turbines achieve an operational availability of about 98%. This in turn means that, to achieve this high availability level, hydraulic components and controls must now work extremely reliably and have a long service life. In functions such as pitch adjustment, yaw and rotor braking, and the provision of hydraulic power from power packs, Bucher Hydraulics components have established an excellent reputation.

Many well-known suppliers of complete hydraulic systems have been relying on Bucher Hydraulics products for decades for the simple reason that they enable them to achieve a high degree of operational reliability. For everyone with responsibility for hydraulic systems, using Bucher Hydraulics components gives the assurance of combining a high level of technical capability with proven functionality. This is a very convincing argument when dealing with wind turbine manufacturers.

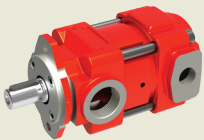

Hydraulic fluid supply

Page 6

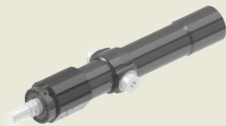

Pitch adjustment

Page 7

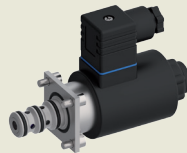

Rotor brake and lock

Page 8



Yaw brake

Page 9



Lubricating, filtering and cooling

Page 10

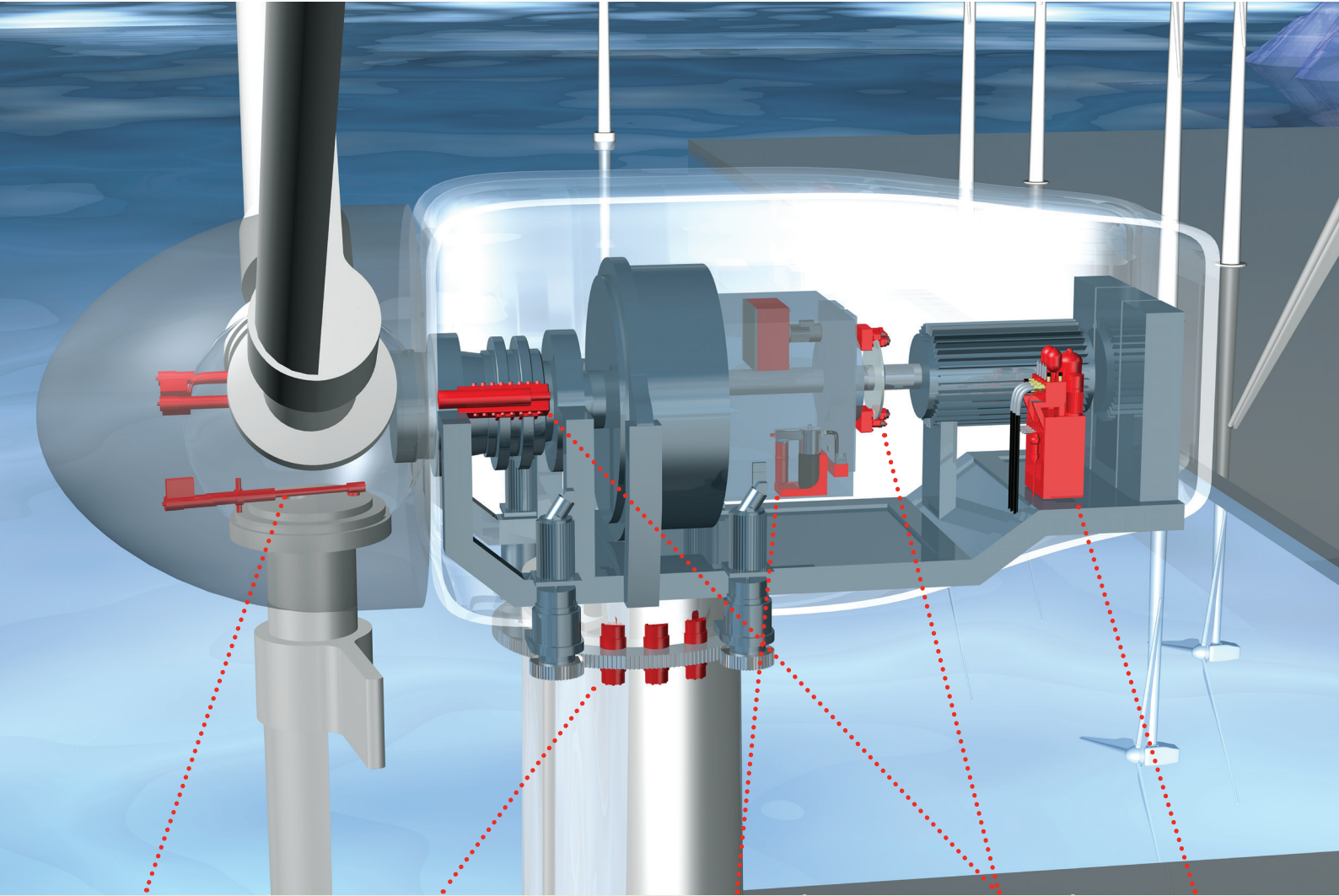

Pitch adjustment

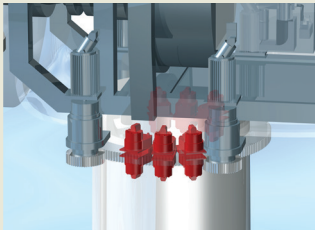

Yaw brake

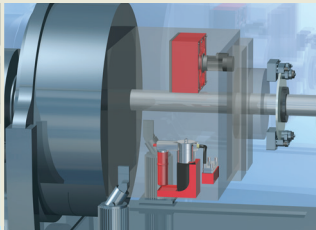

Lubricating, filtering and cooling

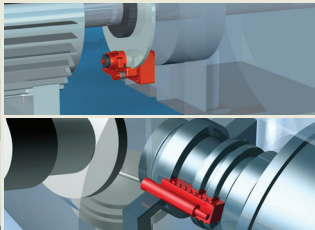

Rotor brake and lock

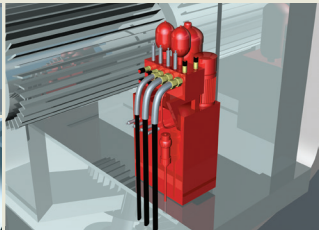

Hydraulic fluid supply

Hydraulic system manufacturers - our partners

Hydraulic Fluid Supply

In the hydraulic power units, highly reliable, non-compensated internal gear pumps from Bucher Hydraulics are used for supplying oil under pressure. The hydraulic system supplies oil to such important units as the pitch adjuster and the brakes – unless small self-contained equipment has been installed – and ensures that the accumulators for the emergency rotor blade cut-out units are full. The hydraulic system manufacturer is our target customer and at the same time the connecting link to the manufacturers of wind turbines. It is for this very reason that we foster close contacts with our system partners and support them by contributing our experience and know-how whenever decisions are being made about the design of a trouble-free hydraulic system.

Internal gear pumps

Series QX internal gear pumps series are ideally suited for fixed as well as variable speeds. Thanks to the use of high-precision gear components and the non-compensated design with no wear-prone compensation mechanisms, this generation of pumps is characterised by maximum operational reliability. QX internal gear pumps have proven themselves in wind turbines for decades and withstand adverse environmental conditions such as very low and very high ambient temperatures. These QX internal gear pumps can be built with 2 gear stages, which increases the operational reliability yet again and ensures reserves of pressure. By using a double-pump configuration, the hydraulic oil supply and an additional cooling circuit can be implemented in a very reliable design with just one drive.

Power packs

The exceptional flexibility of the modular system and the extremely small package size open up an extensive range of control-system solutions. Control valves for the various tasks can be integrated in, or attached directly to, the flange of the power pack.

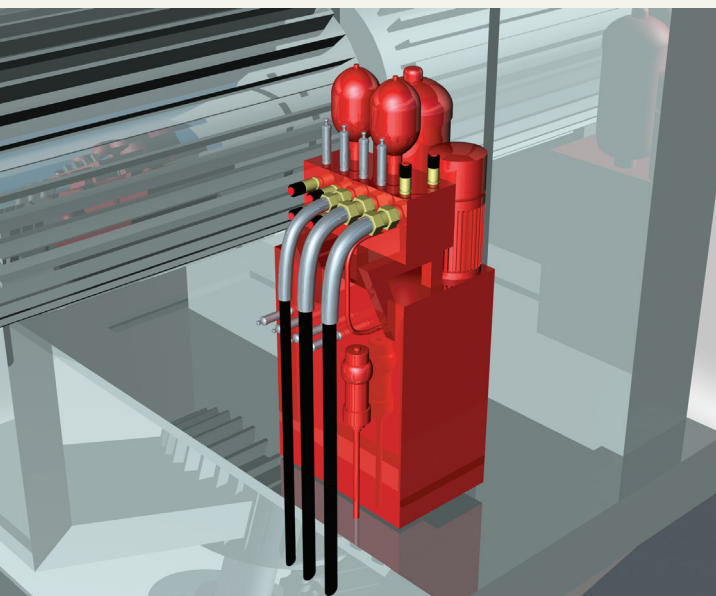

Key advantages

Internal gear pumps

- Low noise emissions
- High pressures
- Maximum levels of reliability and operational safety
- Long service life

Power packs

- Highly flexible
- Simple assembly
- Optimising the motor/pump means greater efficiency

Technical Data

Internal gear pumps QX

Displacement	cm ³ /rev	5 - 250
Continuous pressure max.	bar	320

Power packs UP50 & UP100 Further details, see page 9

Sensitive, safe and economical for wind power

Pitch Adjustment

The pitch adjustment principle (blade angle alteration) entails each individual rotor blade being infinitely adjustable by means of electronics and hydraulics. In this manner the required electrical power is obtained irrespective of varying wind speed.

Solenoid operated directional seat valves

Our 3/2 directional seat valves are used as controls in the pitch-adjustment system principally for ensuring the emergency cut-out. To achieve this in the event of a power failure, each rotor blade must be driven into the neutral position individually and absolutely reliably. Since seat valves are frequently switched on electrically for days or months on end and are thus under constant pressure the demands on them are correspondingly high, for example:

- Solenoid compatibility with 100 % power-on time
- Reliable and instantaneous return of the seat valve poppet
- Positive switch overlap to minimise loss of oil
- No hardening of the internal seat valve poppet-stem seal

Internal gear pumps

The outstanding reliability of the QX internal gear pumps from Bucher Hydraulics ensures that they provide the necessary hydraulic power for the pitch-adjustment system.

Adjusting cylinders

The pitch-adjustment cylinder modules are dependable, pre-assembled units consisting of a control block and the actual adjusting cylinder, which allow separate control of each individual rotor blade. Thanks to this system, the installation can be operated in the optimum range even under variable wind conditions. Because of their high power density and long service life, the cylinders are particularly suitable for large systems. The high accuracy and good dynamics of the control system protect the installation.

Flow control valves

These are used mainly to control emergency cut-out, and due to their load independence they ensure a guaranteed flow rate under varying pressure conditions. For operational safety reasons the actuator modules are mostly configured as redundant systems. Equipped with a fixed orifice and an adjustable pressure compensation spring, they provide flow control within certain limits.

Key advantages

- High switching reliability with lengthy dwell periods under pressure
- Low Δp values
- Switching oil losses are extremely low when used with accumulators
- 100% functionally tested under maximum load conditions

Technical Data

3/2 solenoid operated directional seat valves

Nominal size		10
Flow rate	l/min	60
Operating pressure	bar	315

Adjusting cylinders

Piston diameter	mm	50 - 140
Stroke max.	mm	1500
Operating pressure max.	bar	450

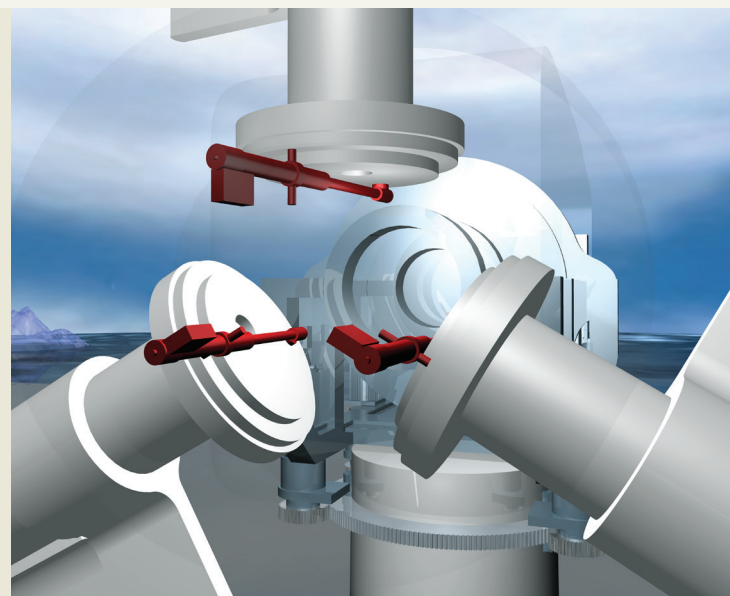

Controlling and securing heavy forces

Rotor Brake and Lock

In installations with a lower electrical power rating and „stall control“, passive brakes are mostly used. The brakes are released by a pressure build-up and applied by the integral spring packs. Conversely, with higher power units, active braking is used. The brakes are then released by pressure decay or by return springs and applied by a pressure build-up. If braking is regulated by on/off hydraulics with no progressive control, very high torques can build up in the entire drive train, which is frequently the cause of damage. In order to control the braking process gently we recommend the use of pressure control. When the rotors are at a standstill they can additionally be locked by means of a hydraulically actuated bolt.

Directional seat valves

The components used for this purpose are 2/2 or 3/2 solenoid operated directional seat valves that are circuited in a redundant arrangement.

Locking cylinders

Locking cylinders are used for locking the rotor position during maintenance work on both on-shore as well as off-shore wind turbines. In series-connected circuits, an automatic end-of-stroke equalisation of the locking cylinders is carried out by the integral valve functions. The sealing components are designed for long service life, and low breakaway force after a long period without moving.

Power packs

Power packs with attached accumulators are used to activate the brakes. The braking pressures usually range between 50 and 250 bar.

Blade-tip adjusting cylinders

These tip-adjusting cylinders act as additional, independent safety components in systems with stall control. If there is a power failure or loss of hydraulic pressure, or wind speeds are too high, the blade tips are synchronously rotated out of the wind, which results in disruption of the airflow. Long life and high reliability therefore have top priority in the design of the components.

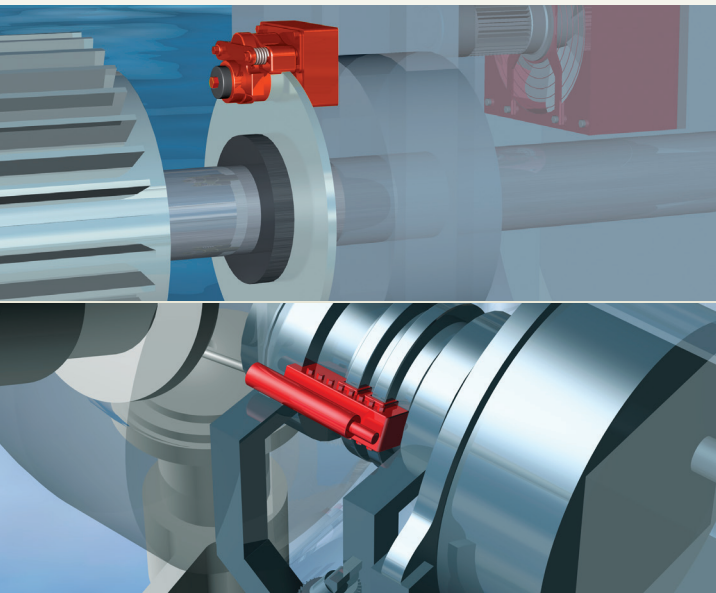

Key advantages

- Highly dependable with extreme switching reliability
- Bidirectional seat-valve shut-off; all ports can be pressurised
- Long service life

Technical Data

2/2 solenoid op. directional seat valves WR22/WRP22		
Nominal size		5 - 16
Flow rate	l/min	300
Operating pressure	bar	250 - 420
3/2 solenoid operated directional seat valves W1D/W1F		
Nominal size		6
Flow rate	l/min	20
Operating pressure	bar	315

Protecting expensive equipment

Yaw Brake

The purpose of the yaw brake is to hold the nacelle in the correct position pointing into the wind. If the nacelle has to be swung around to accommodate a change in wind direction this is achieved by the tower rotator which is driven by electric motors with output gearboxes. To do this, the pressure on the yaw brake has to be reduced to a precisely defined braking pressure. This prevents the effects of wind changes on the nacelle and the resulting fluctuations in force directions from being freely transferred to the gears and drive. Depending on the design of the hydraulics involved, the yaw brake controls are supplied from the central hydraulic system or by independently mounted power packs with a pressure-monitored membrane accumulator.

The following products in the Bucher Hydraulics range have proven and established themselves:

- 2/2 or 3/2 solenoid operated directional seat valves
- 3-way pressure reducing valves
- Accumulator drain valves, small nominal size
- Hydraulic power packs with directly mounted control manifold

All our valves are distinguished by their extremely low leakage, which is of key significance in the design that uses self-contained power packs.

3-way pressure reducing valves

3-way pressure reducing valves offer an optimal characteristic curve, and high stability over the entire control range. The low power loss and long service life are of the greatest significance for use in wind turbines. The integral secondary pressure relief function saves an additional valve on the one hand, and on the other hand the exacting safety requirements for wind turbines are taken into account.

Key advantages

Power packs

- Compact design resulting from integrated valve technology
- High power density

3-way pressure reducing valves

- Direct acting
- Minimum leakage
- Precise pressure control

Technical Data

Power packs UP50 & UP100

Displacement	cm ³ /rev	10
Operating pressure	bar	230

3-way pressure reducing valves DDRB-7M / DDRA-7L

Nominal size		4 - 10
Flow rate	l/min	20 - 70
Operating pressure	bar	315

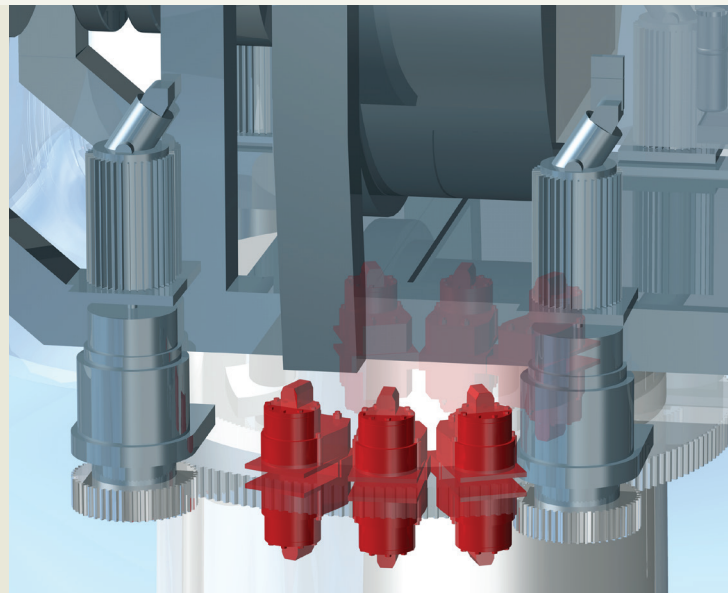

Crucial for a long service life

Lubricating, Filtering and Cooling

There is an increasing tendency towards the use of synthetic gear oils based on polyalphaolefins and esters, and also of polyglycols. Their ageing resistance and load capacity are superior to those of mineral oil, as are their friction and power loss values. Lengthier intervals between maintenance and greater efficiency generate substantial cost savings.

Taking advantage of these superior properties does, however, necessitate more stringent control of oil cleanliness and temperature, both of which have to be monitored continuously. For this purpose a bypass unit is usually employed for filtration and cooling.

Check valves

SAE check valves assume a bypass function to safeguard the filter element and protect the hydraulic circuit against excess pressure. They can also be used as preload valves.

Thermal bypass cooler valves

Thermal bypass cooler valves can also be used for reaching the operating temperature more quickly, which increases the service life of the components. These valves are equipped with an integral pressure relief function to protect the cooler.

Internal gear pumps

For pumping the coolant, QX internal gear pumps offer a cost-effective and reliable solution. By attaching a second QX internal gear pump to the pump that supplies pressurised oil (double-pump design), both circuits can be achieved in a reliable design using just one drive.

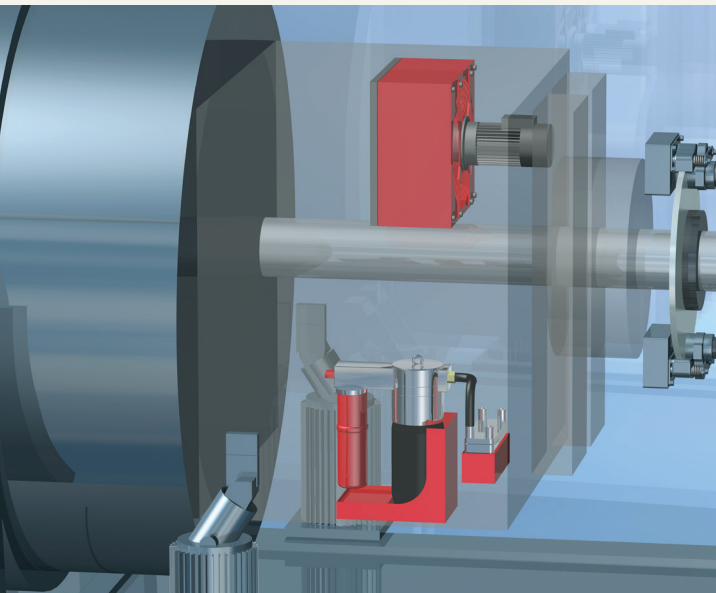

Key advantages

Check valves

- Compact configuration for high flow rates
- Reliable and long-lasting
- Very low leakage

Thermal bypass cooler valves

- Temperature controlled via thermocouple
- Very low Δp values even with cold oil

SAE check valves

Nominal size	3/4" - 2 1/2"	
Nominal flow	l/min	1200
Operating pressure	bar	420

Thermal bypass cooler valves

Nominal size	10 - 16	
Flow rate	l/min	120 - 300
Operating pressure	bar	2 - 10

Protecting premium products

Corrosion Resistance for the Most Stringent Requirements

Preventing corrosion of wind-turbine components such as valves and control manifolds is a key issue, and one that is critically important for manufacturers and suppliers. On application, Bucher Hydraulics can supply valves and control manifolds with a zinc-nickel coating to DIN 50979. These products fulfil the exacting requirements for corrosion protection in aggressive environmental conditions.

Zinc-nickel coating with passivation and sealing

Our hydraulic components with a zinc-nickel coating achieve a minimum of 720 hours resistance against the formation of red rust (i.e. corrosion of the base metal) in the salt spray test to DIN EN ISO 9227 (formerly DIN 50021).

The focus of our actions is always determined by our customers' requirements

- High corrosion resistance of both coating and base metal
- Environmentally friendly Cr(VI)-free coating process
- Maximum corrosion protection even at high temperatures
- Resistant to all common hydraulic fluids
- Optimum price/performance ratio



„ECODraulics“

Bucher Hydraulics is rising to the challenge of striving towards an ecological present and future. Like every idea, ECODraulics begins in the mind, so that it can subsequently express itself in the tangible and very conscious actions of each individual, and not least in products. Our products comply with at least one of the following criteria:

- Reduced energy consumption
- Lower emissions, such as noise or lost heat
- Protection of the environment
- Optimization through system design

> Further informations: www.ecodraulics.com

Smart Solutions. Superior Support.

Bucher Hydraulics GmbH
info@bucherhydraulics.com

For further information visit us at:
www.bucherhydraulics.com