

Proportional Directional Valves

Series L.8S

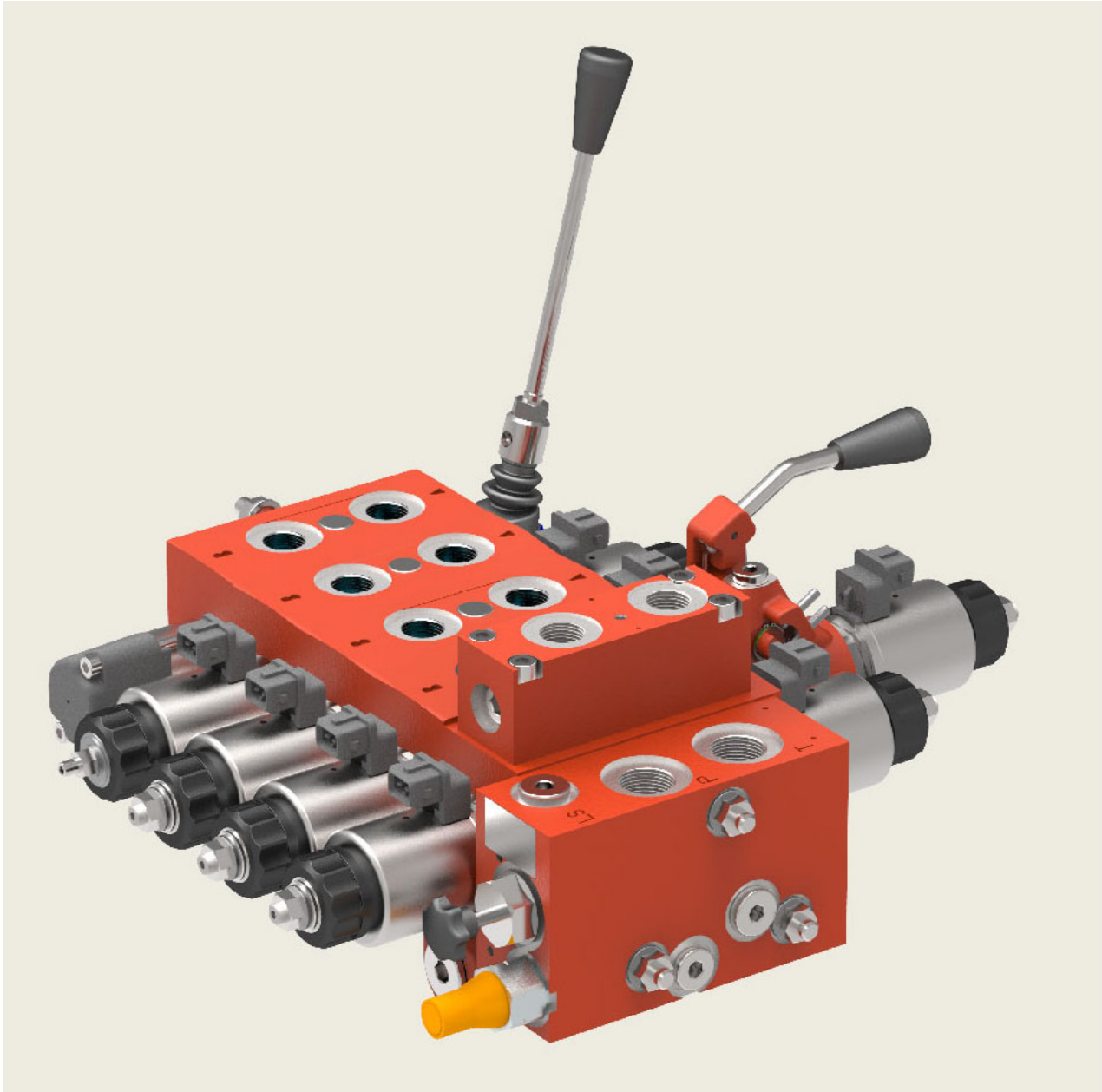

Contents	Page
1 General description	5
2 The main components	6
2.1 Inlet and end sections for valve blocks	6
2.2 Inlet and intermediate sections	6
2.3 Directional valves	7
2.4 Auxiliary valves	7
2.5 General technical data	8
3 Inlet sections	9
3.1 Inlet section without function	9
3.2 Inlet section with pressure relief	10
3.3 Inlet section with 2-way compensator	12
3.4 Inlet section with 3-way compensator	13
4 Intermediate sections	18
4.1 Intermediate section with no control function	18
4.2 Intermediate sections with 2-way pressure compensator	19
4.3 Intermediate sections with 3-way pressure compensator	20
4.4 Intermediate sections with priority function	22
4.5 Intermediate sections with multi-way pressure compensator	23
4.6 Intermediate section with proportional pressure reducing valve	25
5 Directional valves	27
5.1 LA8S-/LF8S- Directional valve	27
5.2 LD8S- /LC8S-Directional valve	34
5.3 LM8S-/LP8S- Directional valve	42
5.4 LH8S - Directional valve	48
6 Auxiliary valves that bolt-on to the top connection face O	53
6.1 Anti-shock/make-up valve (secondary pressure relief)	53
6.2 Check valve (pilot operated non return valve)	55
6.3 Load check valve with anti-shock / make-up valve (pilot operated non-return valve with pressure relief on the actuator side)	59
6.4 Load control valve	61
7 Auxiliary valves that bolt-on to the bottom connection face U	63
7.1 Individual pressure compensator without/with flow cut-off (torque-limiting)	63
7.2 Flow limiter without/with individual pressure compensators	65
7.3 Pressure reducing compensator	67

8	End sections	70
8.1	With no control function	70
8.2	Priority section	71
8.3	With direct-acting pressure relief	73
8.4	With pressure reducing function e.g. for hydraulic joystick	74
8.5	Load control valve with float position	75
8.6	Safety valve for electro-hydraulic steering systems	77

9	Fluid	78
---	-------------	----

10	Accessories	79
10.1	Seat valves series SVH04	79
10.2	Analogue system	80
10.3	Proportional amplifier EBM-300308-DS-MOBI	80
10.4	Assembly kit	80

11	Liability	80
----	-----------------	----

12	Note	80
----	------------	----

1 General description

The L.8S valve series was developed for mobile applications and it features a robust design and small external dimensions.

The L.8S valve range is a very flexible building-block system - its elements can be selected and assembled into a valve block that provides the necessary functions and precisely meets the needs of the application.

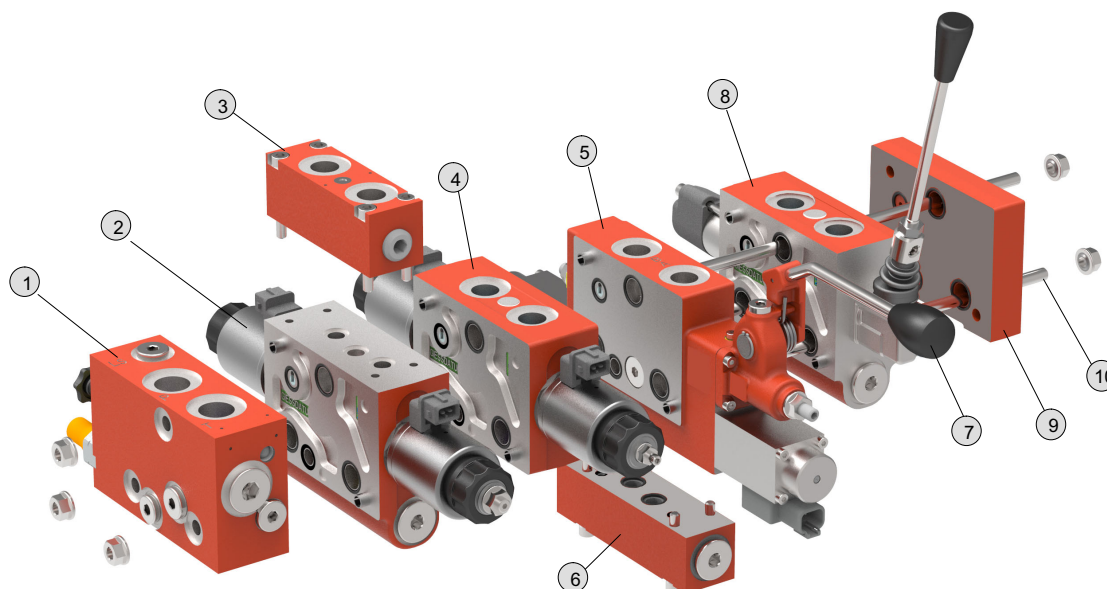

Item	Description
1	Inlet section with 3-way compensator (chapter 3.4)
2	Directional sections with flange face for auxiliary valve, and integral individual pressure compensator / solenoid, direct-acting (chapter 5.2)
3	Auxiliary valves that bolt-on to the top flange face O (chapter 6)
4	Directional valve with direct-acting proportional solenoid (chapter 5.2)
5	Directional sections with port threads and flange face for auxiliary valve / solenoid, two-stage (chapter 5.3)
6	Auxiliary valves that bolt-on to the bottom flange face U (chapter 7)
7	Manual override (chapter 5.3)
8	Directional valve manually operated (chapter 5.1)
9	End section (with no control function) (chapter 8.1)
10	Shaft screw (chapter 11.4)

The following components are available within the range:

Block termination components

- inlet sections
- end sections

Intermediate sections

- 2-way pressure compensators
- 3-way pressure compensators
- multi-way pressure compensators

Directional valves with auxiliary valves

- load check valves
- anti-shock valves
- individual pressure compensators (2-way)

and many more.

Within the valve block, directional valve sections are connected in parallel to the pressure, tank and control lines.

In a system with a fixed-displacement pump, a typical valve block contains a 3-way compensator, several directional valves and the necessary block termination components. The pump is connected to the valve block by a pressure line.

When all directional valves are in the neutral position, the control line unloads the 3-way compensator to tank. The entire flow supplied to the valve therefore passes - with minimal unloaded pressure drop - through the 3-way compensator to the tank port or the carry-over port.

When one of the directional valves is operated, the load pressure is signaled through the control line to the 3-way compensator. The 3-way compensator keeps the pressure difference between the pressure and control galleries inside the block at a constant level (the control pressure). The flow rate to the actuator is therefore always independent of the load and proportional to the open flow area of the metering orifice in the directional valve that has been operated.

In a system with a pressure-controlled, variable-displacement pump, a typical valve block contains (in addition to the directional valves and block termination components) a

2-way compensator that must be positioned between the pump port and the pressure gallery inside the block.

When all directional valves are in the neutral position, the 2-way compensator closes the inlet to the valve block. When one of the directional valves is operated, the 2-way compensator reduces the inlet pressure to a level sufficient to keep the pressure difference between the pressure and control galleries inside the block at a constant level. This ensures that the flow rate to the actuator is independent of the load and proportional to the open flow area of the metering orifice in the directional valve. The flow rate supplied to the valve block therefore matches the actual demand.

When a valve block is supplied by a variable-displacement pump with a load-sensing control, the pump can be connected directly to the valve block by a pressure line. In addition, the control line is connected to the pump control port. If the control pressure can be adjusted directly at the pump control, it is then possible to set the actuator flow rate to the specified value without any additional measures.

If the pump control pressure is preset, the specified flow rate is achieved by placing a 2-way compensator before the directional valve.

When all directional valves are in the neutral position, the pump is de-stroked. When one of the directional valves is operated then, due to the effect of either the pump control or the 2-way compensator positioned before the directional valve, the necessary control pressure is maintained between the pressure and control galleries inside the block. The flow to the selected actuator is therefore independent of the load and proportional to the open flow area of the metering orifice in the directional valve.

In all of the system configurations described up to this point, when several directional valves are operated then, thanks to the shuttle valves situated in the control lines, the actuator with the highest load will dictate the control pressure and the flow rate to the actuator will be independent of the load and proportional to the open flow area of the metering orifice in the directional valve. Load-independence for the less highly-loaded actuators can be achieved by using individual pressure compensators, which reduce the excessive pressure difference sufficiently to ensure that the required control pressure exists at the corresponding directional valve.

2 The main components

2.1 Inlet and end sections for valve blocks

Every L.8S series valve block requires two block termination components in the form of one inlet section and one end section. These two components are used for mounting the block, the block tie bolts pass through them, and they are provided with hydraulic ports.

2.2 Inlet and intermediate sections

2.2.1 2-way pressure compensator

The 2-way compensator is a valve that controls a pressure differential. It is situated inside the block, before the pressure gallery. In this valve, the inlet pressure is reduced by the amount needed to ensure that the control pressure between the pressure and control galleries inside the block is kept constant. In some models, the valve closes the inlet to the block if the pressure in the control line reaches the setting of an upstream pressure relief valve.

The 2-way compensator can be supplied as an inlet section or an intermediate section.

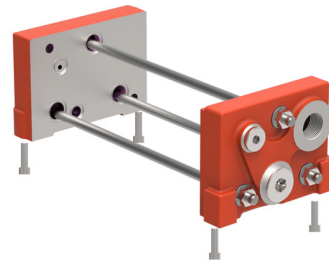

2.2.2 3-way pressure compensator

The 3-way compensator is a valve that controls a pressure differential. It is situated between the pressure gallery and the tank or carry-over gallery. The valve keeps the pressure difference between the pressure and control galleries inside the block at a constant level and surplus flow passes to the tank or carry-over port. If the pressure in the control line reaches the setting of an upstream pressure relief valve, the 3-way compensator opens the connection to tank, thus limiting the pressure in the pressure gallery inside the block. In one particular model, the function of the 3-way compensator can be customized to suit the requirements of individual applications. The adjustment can be done with a shut-off screw that is accessible from the outside.

2.3 Directional valves

The control options (LA, LF, LH, LC and LP or ON/OFF (LM, LD) for L.8S series directional valves enable continuous changes to the flow area of the metering orifice, which in turn determines the flow rate that is supplied to the actuator. This is achieved by arranging that in the first group of valves the spool can stop at any desired point along its total stroke, whereas the spools of LM/LD valves travel from one end of the stroke to the other when they are switched, and do not stop at intermediate positions.

The various directional valves are differentiated by their type of operation. The LA directional valves are mechanically operated by hand lever. The LF directional valves are mechanically operated by remote cable. The LD and LC directional valves are electrically operated, direct acting. The LM and LP directional valves have electro-hydraulic operation. The solenoids of LD, LC, LM and LP directional valves are fitted with a manual override as standard, but in the case of the LM and LP valves the overrides only work if pressure is present at the valve inlet. Series LD, LC, LH, LM and LP directional valves can be equipped with an optional hand lever for manual-override operation of the valve spool. Operating two valves in parallel is dependent on the pressure demands of the actuator connected to each valve. However, the LD-, LC-, LA- and LF- directional valves can optionally be ordered with an integral individual pressure compensator.

2.4 Auxiliary valves

The auxiliary valves fit onto the directional valves and can be flange-mounted on the top (connection face O) or bottom (connection face U) of the valve, which is specially designed for this purpose.

For mounting on connection face O, these alternative auxiliary valves are available:

- anti-shock valve (secondary pressure relief valve with make-up facility)
- load control valve
- load check valve (hydraulically and electrically pilot-operated check valve)
- various special bolt-on plates

Anti-shock valves are used to prevent over-pressure in the actuator lines and/or cavitation with negative loads.

Load control valves provide controlled, load-independent lowering of over-running (pulling) loads. The anti-shock function is integrated and optimal adjustable.

Load check valves hold the actuator, which may be under load, with virtually zero leakage. The actuator is released by applying pressure to the other actuator port.

For mounting on connection face U, these alternative auxiliary valves are available:

- individual pressure compensator
- flow limiter
- pressure-reducing compensator

An individual compensator is used when the flow rate to the actuator must be independent of load, but the inlet compensator cannot perform the necessary pressure-control function. LA-, LC-, LD and LF-directional valves are also available with integrated individual pressure compensator.

Additional function blocks are described in detail in the relevant sections.

2.5 General technical data

General characteristics	Unit	Description, value
Recommended mounting attitude	GPM (l/min)	With spool axis horizontal
Nominal flow rate	GPM (l/min)	max. 39.63 (150)
Actuator flow rate	GPM (l/min)	max. 19.81 (75)
Inlet pressure P + D	PSI (bar)	max. 4351 (300) ²⁾
Actuator pressure A + B	PSI (bar)	max. 4351 (300) ²⁾
Intermittent pressure (max. 10 sec/min)	PSI (bar)	max. 4569 (315)
Return line pressure	PSI (bar)	max. 580 (40) ¹⁾
Hydraulic fluid		Recommendation: high-quality fluids with a mineral-oil base, such as HLP oils to DIN 51524 part 2
Seal material		NBR
Fluid temperature	°F (C°)	-13 ... +176 (-25 ... +80)
Ambient temperature	°F (°C)	-13 ... +122 (-25 ... +50)
Viscosity range	ft ² /s (mm ² /s)	1.08 ... 41.04 (10 ... 380)
Minimum fluid cleanliness level		ISO 446, code 20/18/15
Nominal voltage range of switching solenoids	VDC	12V $\underline{\Delta}$ 10.8 ... 14 24V $\underline{\Delta}$ 21.6 ... 28
Servo frequency	Hz	preferably 100
Threaded ports		to DIN 3852 and DIN ISO 228-1
Tie bolts		M8, tensile grade 10.9 (tightening torque 266 lbs (30 Nm))
Corrosion protection		Valve blocks primed colour: black RAL 9005 coating thickness 30 to 50 μm ³⁾

1) 1450 PSI (100 bar) return line pressure for brief periods, with max. inlet pressure 3046 PSI (210 bar). 3046 PSI (210 bar) for P and T in individual cases. For higher pressures, consult Bucher Hydraulics.

2) The stated pressures are the maximum absolute pressure limits for a tank line pressure of 145 PSI (10 bar).
Note: Some components have lower individual pressure ratings.

3 Inlet sections

3.1 Inlet section without function

3.1.1 Description

Inlet sections without function are used to begin the block when no control functions are needed (e.g. LS applications). Ports P, T and LS, and tapped holes for securing the valve block are provided.

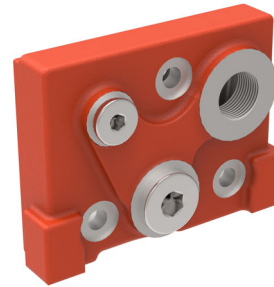

3.1.2 Overview of sections

Symbol	Description	Part number
	LU8SPOG-0U78 <ul style="list-style-type: none"> Without function port threads to ISO 11926: 7/8" -14 UNF-2B 	100026482

3.1.3 Dimensions [in (mm)]

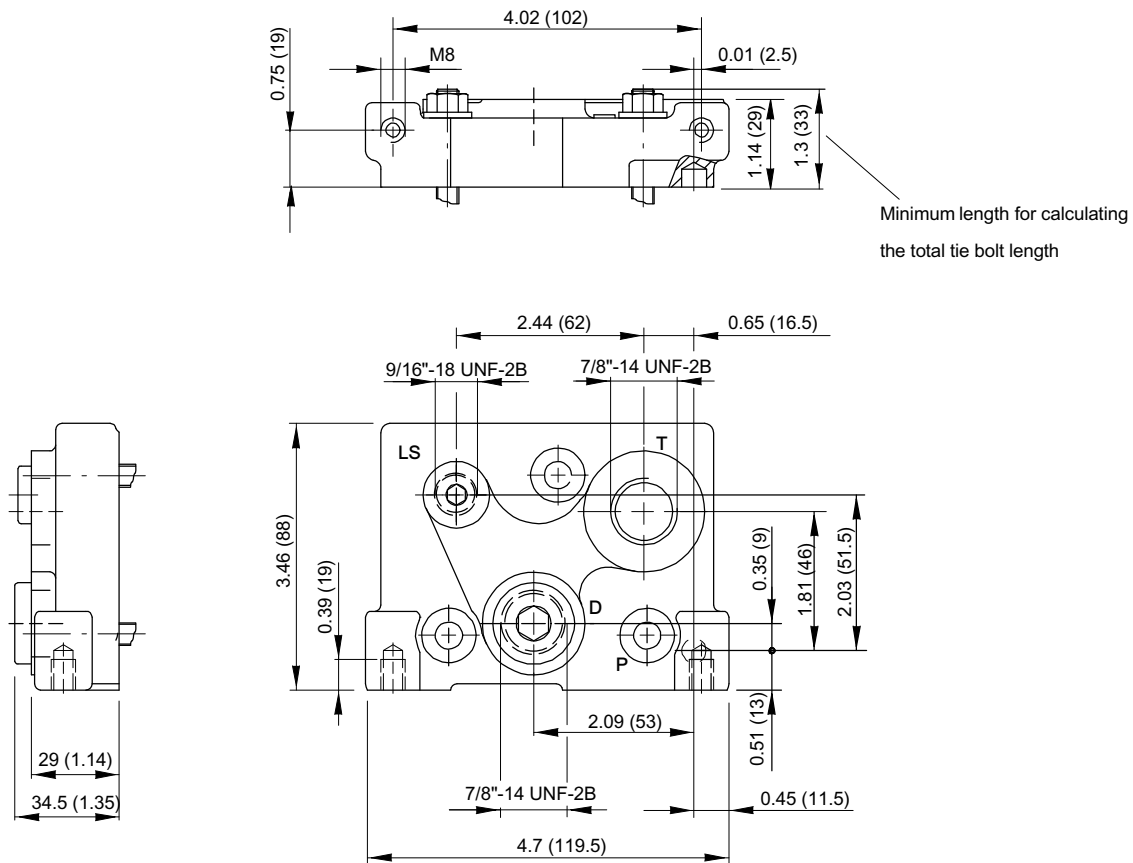

3.2 Inlet section with pressure relief

3.2.1 Description

3.2.1.1 Inlet pressure relief two-stage LU8SPOD

This is used to begin the block, and has an integral two-stage pressure relief function (e.g. safety pressure relief in an LS system). Ports P, T and LS, and tapped holes for securing the valve block are provided.

3.2.1.2 Inlet pressure relief direct acting LU8SPOS

This is used to begin the block, and has an integral direct-acting pressure relief function (e.g. secondary pressure relief in an LS system). The application limits must not be exceeded. By screwing in damping and bypass orifices, many possibilities for combating oscillation problems in LS systems can be created. Ports P, T and LS, and tapped holes for securing the valve block are provided.

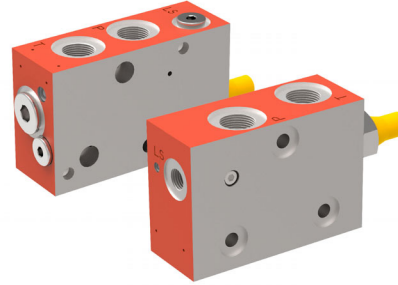

3.2.2 Technical data

General characteristics	Unit	Description, value
Inlet pressure	PSI (bar)	max. 4351 (max. 300)
Nominal flow rate	GPM (l/min)	see performance graphs 3.2.3
Pressure relief	PSI (bar)	adjustable

3.2.3 Performance graphs

3.2.3.1 Inlet pressure relief two-stage LU8SPOD

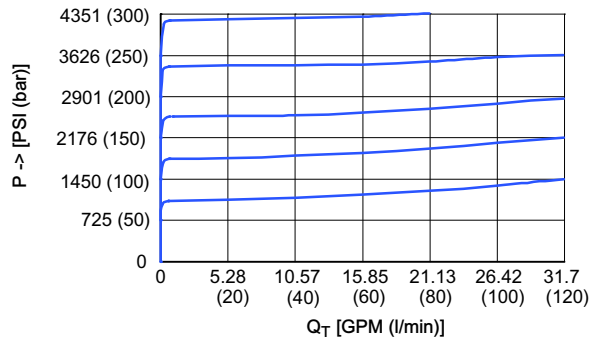

3.2.3.2 Inlet pressure relief direct acting LU8SPOS

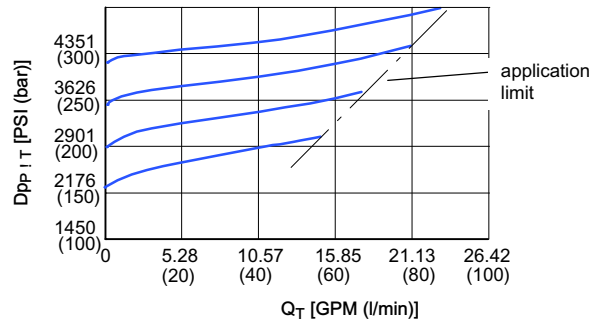

3.2.4 Overview of sections

3.2.4.1 Inlet pressure relief two-stage

Symbol	Description	Part number
	LU8SPOD-0U78 P= <ul style="list-style-type: none"> relief adjustment range 870 ... 4351 PSI (60 ... 300 bar) nominal flow rate 31.7 GPM (120 l/min) port threads to ISO 11926: 7/8"-14 UNF-2B ⇒ Specify the pressure relief setting in bar (Example: LU8SPOD-0U78 P=200)	100030560

3.2.4.2 Inlet pressure relief direct acting

Symbol	Description	Part number
	LU8SPOS1-0U78 P= <ul style="list-style-type: none"> • application limit see performance graph • relief adjustment range 508 ... 1378 PSI (35...95 bar) P = • port threads to ISO 11926: 7/8"-14 UNF-2B ⇒ Specify the pressure relief setting in bar, (35...95 bar) (Example: LU8SPOS1-0U78 P=200)	-
	LU8SPOS2-0U78 P= <ul style="list-style-type: none"> • application limit see performance graph • relief adjustment range 1378 ... 3046 PSI (95...210 bar) P = • port threads to ISO 11926: 7/8"-14 UNF-2B ⇒ Specify the pressure relief setting in bar, (35...95 bar) (Example: LU8SPOS2-0U78 P=200)	100038091
	LU8SPOS3-0U78 P= <ul style="list-style-type: none"> • application limit see performance graph • relief adjustment range 3046 ... 4351 PSI (210...300 bar) P = • port threads to ISO 11926: 7/8"-14 UNF-2B ⇒ Specify the pressure relief setting in bar, (35...95 bar) (Example: LU8SPOS3-0U78 P=200)	-

3.2.5 Dimensions [in (mm)]

3.2.5.1 LU8SPOD-...

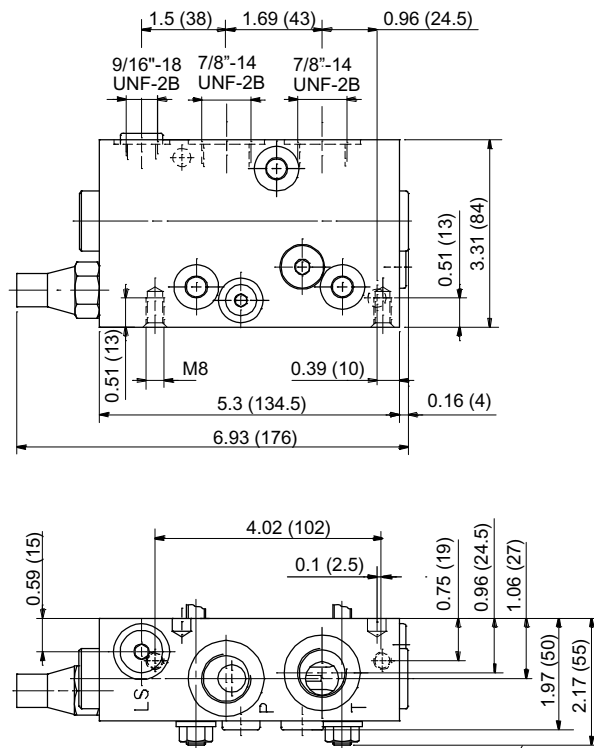

Minimum length for calculating the total tie bolt length

3.2.5.2 LU8SPOS-...

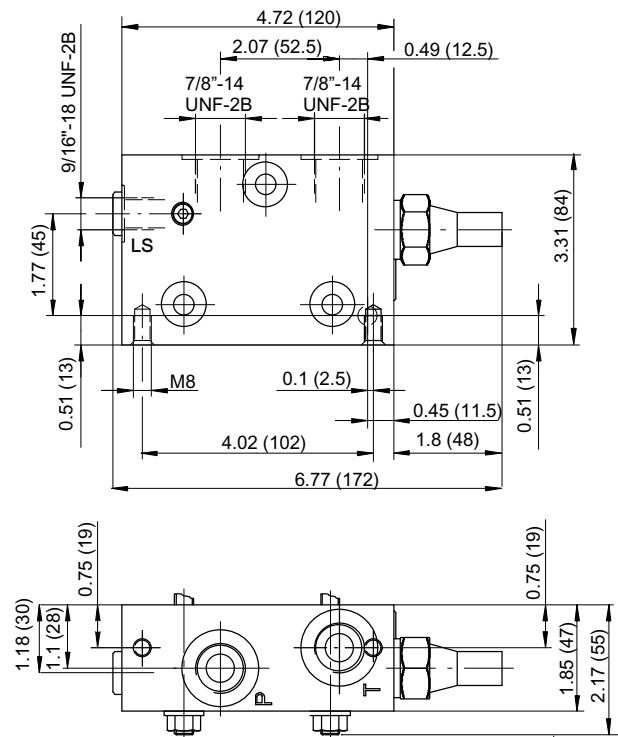

Minimum length for calculating the total tie bolt length

3.3 Inlet section with 2-way compensator

3.3.1 Description

These are used to begin the block and have an integral 2-way compensator; optionally with flow cut-off from a pre-set pressure. A typical application is the parallel operation of two valve blocks in an LS-system, where only one spool at a time is operated within each block.

Ports P and LS, and tapped holes for securing the valve block are provided. The tank connection must be implemented in the intermediate or end section.

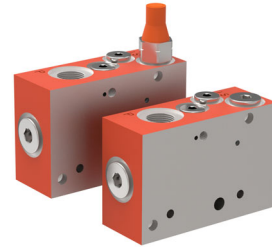

3.3.2 Technical data

General characteristics	Unit	Description, value
Inlet pressure	PSI (bar)	max. 4351 (300)
Nominal flow rate / open-centre systems	GPM (l/min)	26.42 (100)
Pressure relief	PSI (bar)	adjustable, 725 ... 4351 (50 ... 300)

3.3.3 Performance graphs

3.3.3.1 Variation of the actuator flow rate with inlet pressure when using an LU8SSKA/SKB inlet section

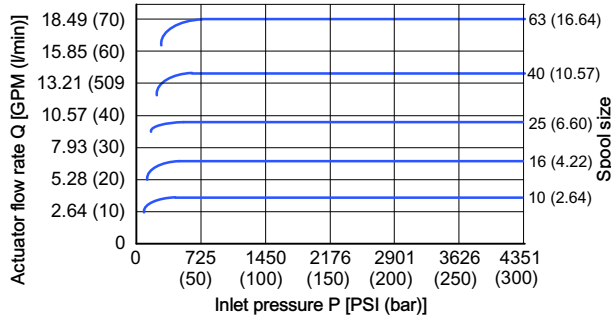

3.3.3.2 Flow cut-off function with an LU8SSKB inlet section

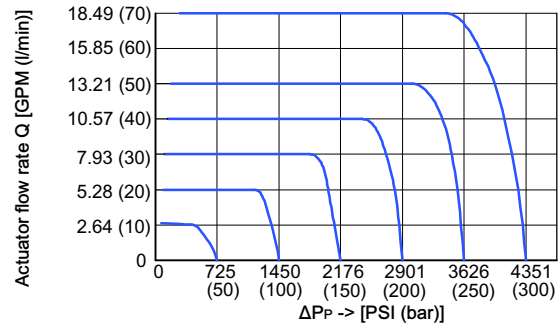

3.3.4 Overview of sections

Symbol	Description	Part number
	LU8SSKA-0U78 <ul style="list-style-type: none"> control $\Delta p = 174$ PSI (12 bar) without flow cut-off 	100025088
	LU8SSKB-0U78 P= <ul style="list-style-type: none"> control $\Delta p = 174$ PSI (12 bar) with flow cut-off ⇒ Specify the pressure relief setting in bar	100036400

3.3.5 Dimensions [in (mm)]

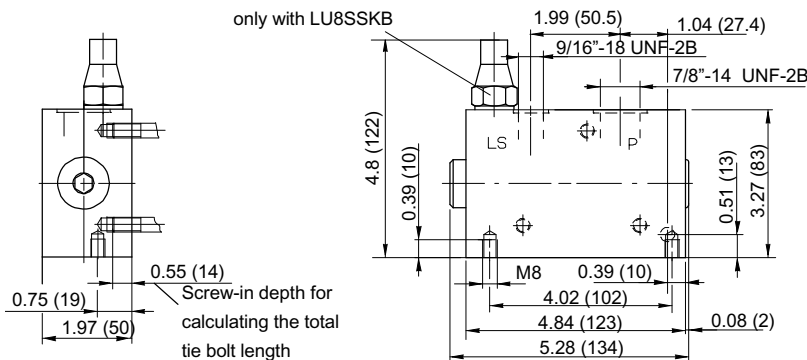

3.4 Inlet section with 3-way compensator

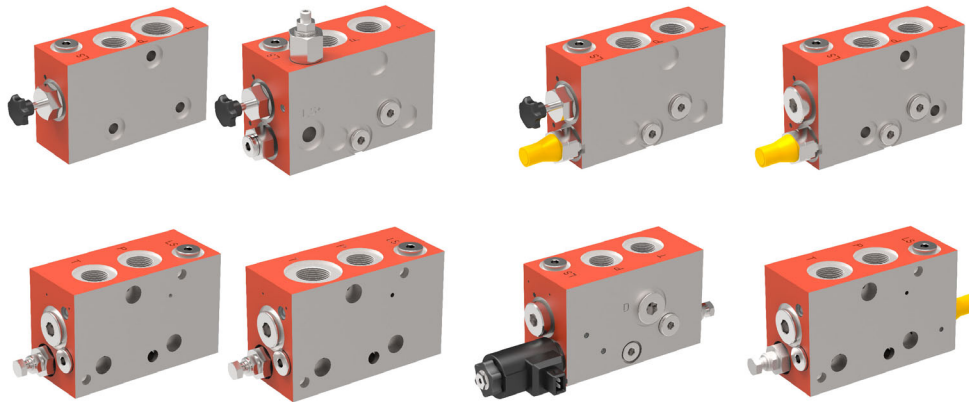

3.4.1 Description

These are used to begin the block and have an integral 3-way compensator; optionally with the additional functions shown below. These inlets are used with fixed displacement pumps.

In essence, they can be applied in conjunction with a fixed-displacement pump for control of unloading and flow control that is independent of the load.

- **LU8SSCK**

Provides a 3-way compensator function with the facility to change over to LS- or constant pressure systems. This is typical with towed harvesters.

- **LU8SSCK/29**

Provides a 3-way compensator function, with the ability to change over to LS or constant-pressure systems.

In the case of reduced flow rates caused by increased pressure losses in the P line, or if the load sensing line has a large leakage or is connected to tank through an orifice (bleed-off), the integral adjustable pressure booster can amplify the LS signal accordingly.

In special cases, increased amplification of the LS signal can result in higher actuator flow rates and thus increase the performance of the system.

- **LU8SSCL**

Provides a 3-way compensator function and two-stage pressure relief that is adjustable from outside the valve, with the ability to change over to LS or constant-pressure systems. This is typical with towed harvesters. The pressure relief is only operative in the open system.

- **LU8SSCS**

Provides a 3-way compensator function and 2-stage pressure relief that is adjustable from outside the valve.

- **LU8SSCU**

Provides a 3-way compensator function with an independent system pressure relief function.

- **LU8SSCX**

Provides a 3-way compensator function and two-stage pressure relief that is adjustable from outside the valve, and an independent system pressure relief function. The surplus flow is available at port D for other applications. The valve block's own functions have priority over port D. The valve block can be protected at a lower pressure setting by the two-stage relief valve, so that excess flow is always available at port D.

- **LU8SSCW**

Provides a 3-way compensator function with an independent system pressure relief function. The surplus flow is available at port D for other applications. The valve block's own functions have priority over port D. When the valve block's pressure relief function is active, there is no longer any flow to port D.

- **LU8SSCE**

Provides a 3-way compensator function with an independent system pressure relief function. When it is de-energised, a 2/2 seat valve unloads the internal LS line to tank, which means that the seat valve must first be energised before the valve block is functional. Applications are in safety circuits, e.g. emergency stop controls.

3.4.2 General technical data

General characteristics	Unit	Description, value
Inlet pressure	PSI (bar)	max. 4351 (max. 300)
Nominal flow rate	GPM (l/min)	31.70 (120)
Unloaded pressure P -> T (D)	PSI (bar)	see performance graphs chapter 3.4.3
Pressure relief	PSI (bar)	adjustable, 725 ... 4351 ²⁾ (50 - 300)
Nominal voltage ¹⁾	VDC	12 or 24
Plug type		AMP Junior Timer, Deutsch plug DT04-2P-EP04
Power consumption ¹⁾	Watt	27
Duty cycle ¹⁾	%	100
Protection class ¹⁾		AMP: IP65 DT04-2P-EP04: IP67 (DIN EN 60529)

1) Only with LU8SSCE

2) Higher pressure on request

3.4.3 Performance graphs

3.4.3.1 Maximum flow rate at directional valve (without individual pressure compensator) when using an LU8SSC inlet section.

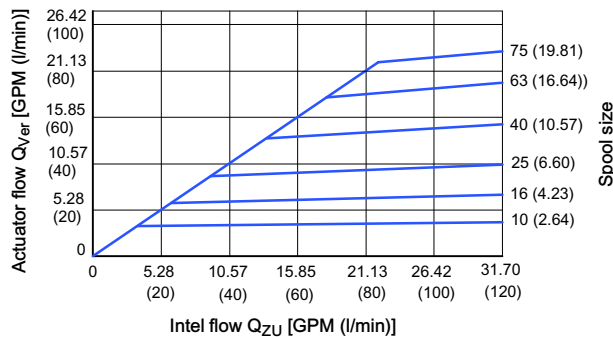

3.4.3.2 Unloaded pressure in neutral position, (for other unloaded pressures consult Bucher Hydraulics).

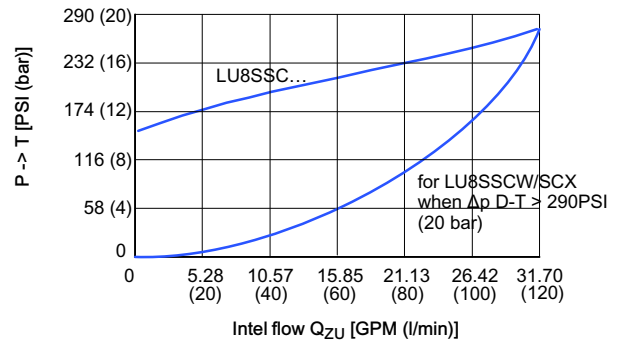

3.4.3.3 Two-stage pressure relief characteristic inlet section LU8SSCS/SCX

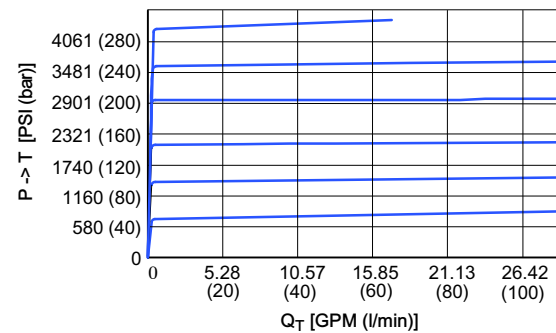

3.4.3.4 System pressure relief characteristic inlet section LU8SSCE/SCU/SCW/SCX

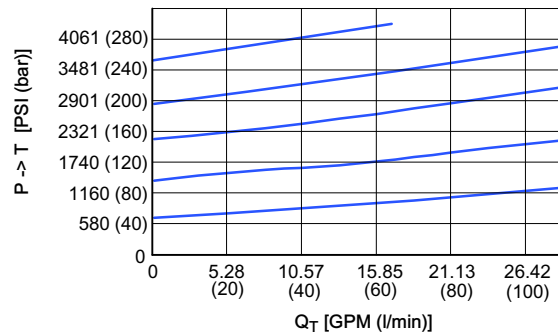

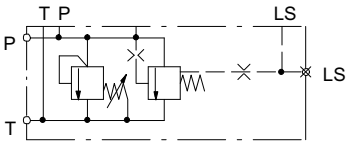
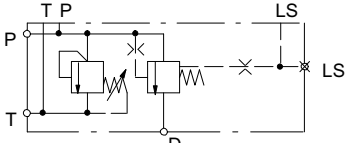
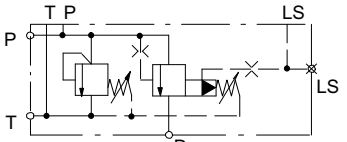
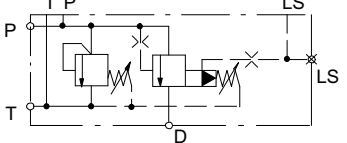
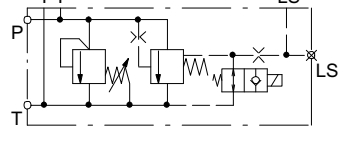

3.4.4 Overview of sections

Symbol	Description	Part number
	LU8SSCK-0U78 <ul style="list-style-type: none"> without pressure relief compensator can be disabled for LS systems control $\Delta p = 174$ PSI (12 bar) with active pressure compensator port threads to ISO 11926: $\frac{7}{8}$"-14 UNF-2B 	100037845
	LU8SSCK-0U78/04 <ul style="list-style-type: none"> without pressure relief compensator can be disabled for LS systems for using with seat valves SVH04M - straight-through tie bolts control $\Delta p = 174$ PSI (12 bar) with active pressure compensator port threads to ISO 11926: $\frac{7}{8}$"-14 UNF-2B 	-
	LU8SSCK-0U78/12 <ul style="list-style-type: none"> without pressure relief compensator can be disabled for LS systems for using with seat valves SVH04M - straight-through tie bolts control $\Delta p = 174$ PSI (12 bar) with active pressure compensator no tank connection for bolt-on functions port threads to ISO 11926: $\frac{7}{8}$"-14 UNF-2B 	-
	LU8SSCK-0U78/29 <ul style="list-style-type: none"> without pressure relief compensator can be disabled for LS systems with integral LS-compensator, boost pressure 116 PSI (8 bar) max., factory setting 87 PSI (6 bar) control $\Delta p = 174$ PSI (12 bar) with active pressure compensator port threads to ISO 11926: $\frac{7}{8}$"-14 UNF-2B 	-
	LU8SSCL-0U78 P= <ul style="list-style-type: none"> with two-stage pressure relief in fixed-displacement pump system control $\Delta p = 174$ PSI (12 bar) port threads to ISO 11926: $\frac{7}{8}$"-14 UNF-2B ⇒ Specify the pressure relief setting in bar	-
	LU8SSCL-0U78/04 P= <ul style="list-style-type: none"> with two-stage pressure relief in fixed-displacement pump system for using with seat valves SVH04M - straight-through tie bolts control $\Delta p = 174$ PSI (12 bar) port threads to ISO 11926: $\frac{7}{8}$"-14 UNF-2B ⇒ Specify the pressure relief setting in bar	-
	LU8SSCS-0U78 P= <ul style="list-style-type: none"> with two-stage pressure relief control $\Delta p = 174$ PSI (12 bar) port threads to ISO 11926: $\frac{7}{8}$"-14 UNF-2B ⇒ Specify the pressure relief setting in bar	100027531
	LU8SSCS-0U78/04 P= <ul style="list-style-type: none"> with two-stage pressure relief for using with seat valves SVH04M - straight-through tie bolts control $\Delta p = 174$ PSI (12 bar) port threads to ISO 11926: $\frac{7}{8}$"-14 UNF-2B ⇒ Specify the pressure relief setting in bar	100031679

	<p>LU8SSCU-0U78 P=</p> <ul style="list-style-type: none"> with system pressure relief, direct acting, control $\Delta p = 174 \text{ PSI (12 bar)}$ port threads to ISO 11926: $7/8''\text{-}14 \text{ UNF-}2\text{B}$ <p>⇒ Specify the pressure relief setting in bar, (50 ... 315 bar)</p>	<p>-</p>
	<p>LU8SSCW-0U78 P=</p> <ul style="list-style-type: none"> with system pressure relief with surplus-flow port internal valve block has priority over D control $\Delta p = 174 \text{ PSI (12 bar)}$ port threads to ISO 11926: $7/8''\text{-}14 \text{ UNF-}2\text{B}$ <p>⇒ Specify the pressure relief setting in bar, (50 ... 315 bar)</p>	<p>100029384</p>
	<p>LU8SSCX-0U78 P= P1=</p> <ul style="list-style-type: none"> with system pressure relief with surplus-flow port internal valve block has priority over D with pressure relief for the valve block control $\Delta p = 174 \text{ PSI (12 bar)}$ port threads to ISO 11926: $7/8''\text{-}14 \text{ UNF-}2\text{B}$ <p>⇒ Specify the pressure relief setting in bar, (50 ... 315 bar)</p>	<p>100029848</p>
	<p>LU8SSCX-0U11 P= P1=</p> <ul style="list-style-type: none"> with system pressure relief with surplus-flow port internal valve block has priority over D with pressure relief for the valve block control $\Delta p = 174 \text{ PSI (12 bar)}$ port threads to ISO 11926: $7/8''\text{-}14 \text{ UNF-}2\text{B}$ <p>⇒ Specify the pressure relief setting in bar, (50 - 315 bar)</p>	<p>100033113</p>
	<p>LU8SSCE-0U78T12 P=</p> <ul style="list-style-type: none"> with direct-acting pressure relief function emergency stop function control $\Delta p = 174 \text{ PSI (12 bar)}$ port threads to ISO 11926: $7/8''\text{-}14 \text{ UNF-}2\text{B}$ plug type to DIN 43650 (other plug types on request) nominal voltage 12 VDC <p>⇒ Specify the pressure relief setting in bar, (50 - 315 bar)</p>	<p>100034518</p>

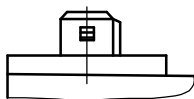
3.4.5 Connector socket

<p>AMP Junior Timer J</p>	<p>Deutsch plug DT04-2P-EP04 T</p>
	

3.4.6 Dimensions [in (mm)]

3.4.6.1 LU8SSCE-...G

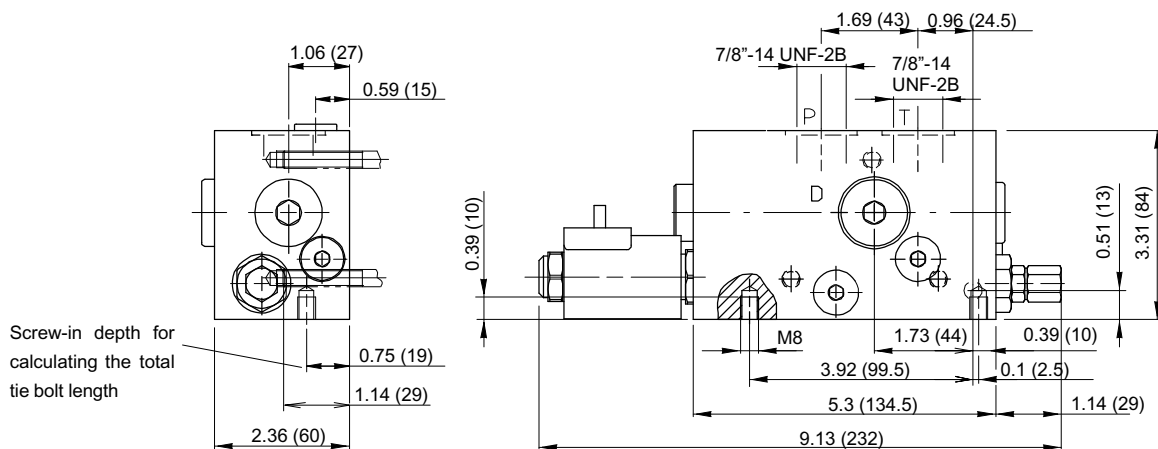

3.4.6.2 LU8SSCK / SCS / SCL

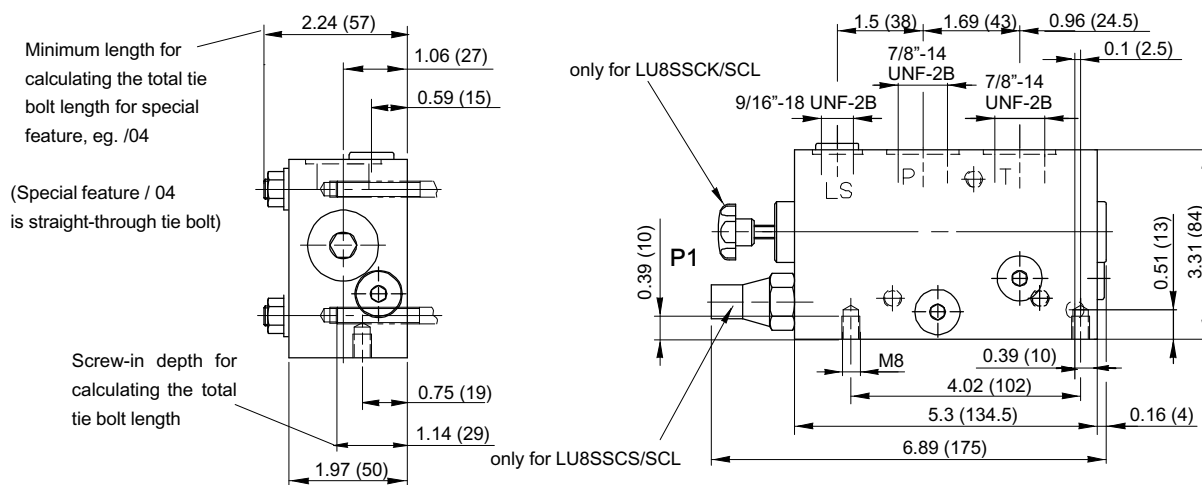

3.4.6.3 LU8SSCU / SCW / SCX

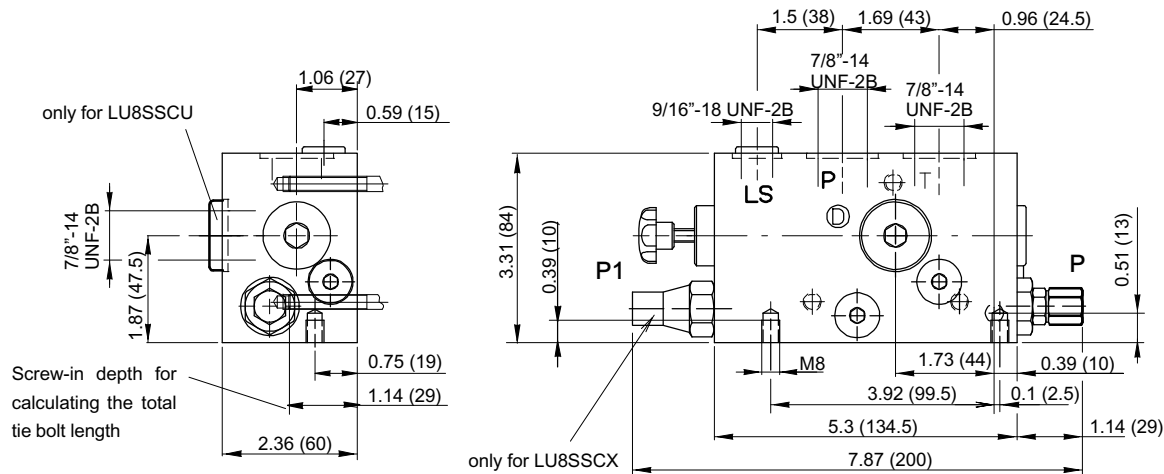

4 Intermediate sections

4.1 Intermediate section with no control function

4.1.1 Description

These intermediate sections are used as spacer section (e.g. with large port fittings) or, in the case of the LU8SBTP-0; for hydraulic partitioning of the P and LS lines within the valve block; T is continuous.

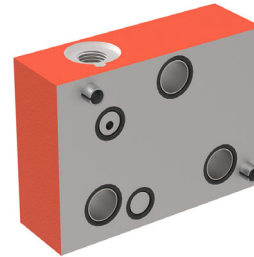

4.1.2 Overview of sections

Symbol	Description	Part number
	LU8SBDP-0 • block spacer section • P, T and LS continuous	100020651
	LU8SBTP-0 • block partition section • P and LS blocked, T continuous	100020652
	LU8SBTL-0U91 • block partition section • P blocked, T continuous, LS in front half of block to T, in rear half to separate LS port. • port threads to ISO 11926: 9/16"-18 UNF-2B	-

4.1.3 Dimensions [in (mm)]

4.1.3.1 LU8SBDP / BTP

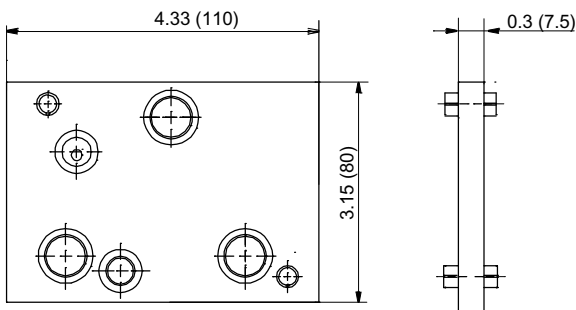

4.1.3.2 LU8SBTL

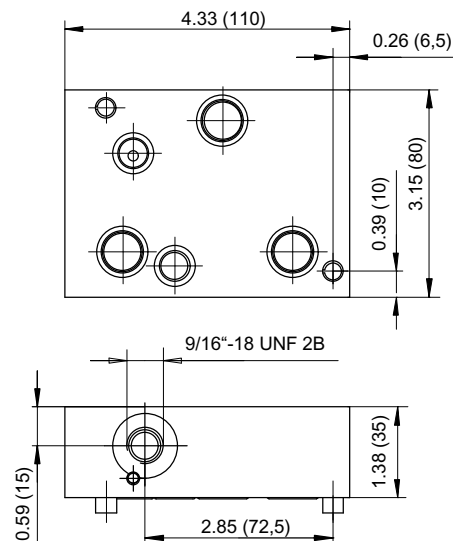

4.2 Intermediate section with 2-way pressure compensator

4.2.1 Description

These are intermediate sections with an integral 2-way pressure compensator, optionally with flow cut-off from a pre-set pressure. Typical applications: valve block sections that, in general, experience lower pressures are combined with this compensator to ensure load-independent operation. Ports P and LS are provided.



4.2.2 Technical data

General characteristics	Unit	Description, value
Inlet pressure	PSI (bar)	max. 4351 (max. 300)
Nominal flow rate	GPM (l/min)	see performance graphs 4.2.3
Pressure relief valve	PSI (bar)	adjustable

4.2.3 Performance graphs

4.2.3.1 Variation of the actuator flow rate with inlet pressure when using an LU8SSKC / SKD intermediate section

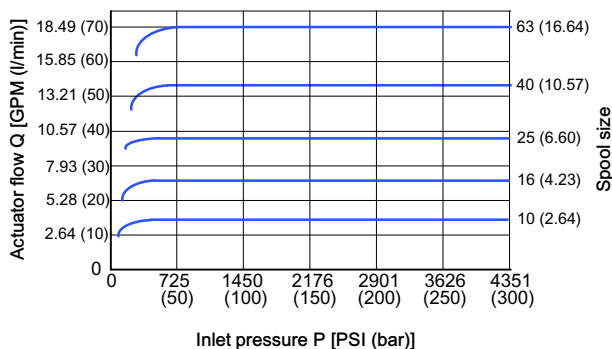

4.2.3.2 Flow cut-off function with an LU8SSKD intermediate section

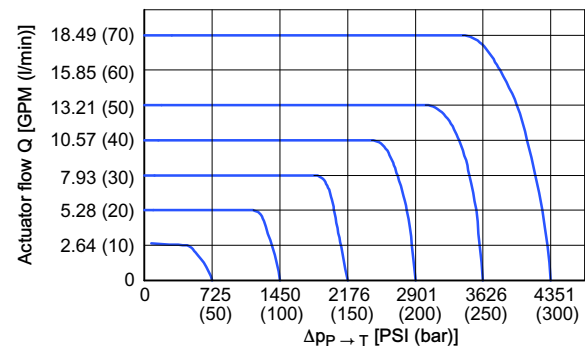

4.2.4 Overview of sections

Symbol	Description	Part number
	LU8SSKC-0U78 <ul style="list-style-type: none"> nominal flow rate 26.42 GPM (100 l/min) port threads to ISO 11926: 7/8"-14 UNF-2B 	100036461
	LU8SSKD-0U78 P= <ul style="list-style-type: none"> nominal flow rate 26.42 GPM (100 l/min) with adjustable pressure relief valve for flow cut-off port threads to ISO 11926: 7/8"-14 UNF-2B ⇒ Specify the pressure relief setting in bar, (50 ... 300 bar)	-

4.2.5 Dimensions [in (mm)]

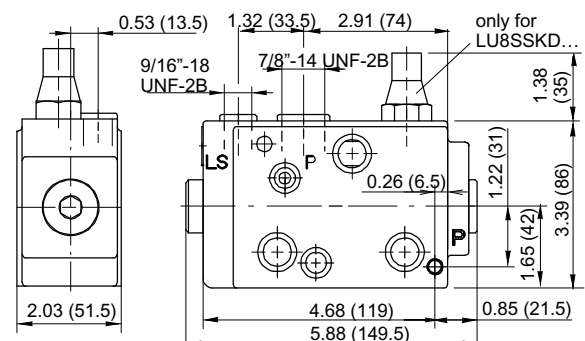

4.3 Intermediate sections with 3-way pressure compensator

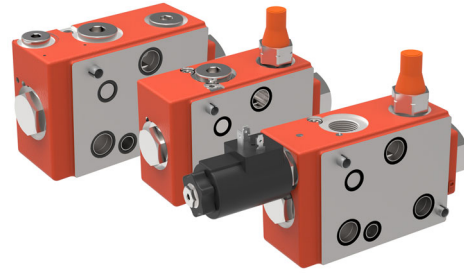

4.3.1 Description

These 3-way compensators are intermediate sections with the additional functions shown below. In essence, they can be applied in conjunction with a fixed-displacement pump for control of unloading, and flow control that is independent of the load. Ports P, and D and LS as appropriate, are provided.

4.3.2 Function

- **LU8SSBU**
Provides a 3-way compensator function with 2-stage pressure relief and a reduction in the unloaded pressure from the standard 174 PSI (12 bar) to approx. 87 PSI (6 bar).
- **LU8SSBK**
Includes a 3-way compensator function with the facility to change over to LS or constant-pressure systems. This is typical with towed harvesters.

- **LU8SSBW**
Provides a 3-way compensator function and the surplus flow is available at port D or internally for other applications. Both flows are protected by a two-stage pressure relief valve. On reaching the maximum pressure in the priority side, which can then be loaded up to the maximum pressure setting.

4.3.3 Technical data

General characteristics	Unit	Description, value
Inlet pressure ¹⁾	PSI (bar)	max. 4351 (max. 300)
Nominal flow rate	GPM (l/min)	31.7 (120)
Unloaded pressure P -> T (LU8SSBU/SBT/SBL/SBK)	PSI (bar)	see performance graphs chapter 4.3.4
Pressure relief	PSI (bar)	adjustable, 725 ... 4351 (50 ... 300)
Nominal voltage ²⁾	VDC	12 or 24
Plug type		GDM plug DIN 43650, AMP Junior Timer, Deutsch plug DT04-2P-EP04
Power consumption ²⁾	Watt	27
Duty cycle ²⁾	%	100
Protection class ²⁾		AMP, GDM: IP65 DT04-2P-EP04: IP67 (DIN EN 60529)

1) Inlet pressure for LU8SSBU-....G.. and LU8SSBW-....G.. max. 3626 PSI (max. 250 bar).

2) Only with electrical unloading.

4.3.4 Performance graphs

4.3.4.1 Unloaded pressure in neutral position, LU8SBW

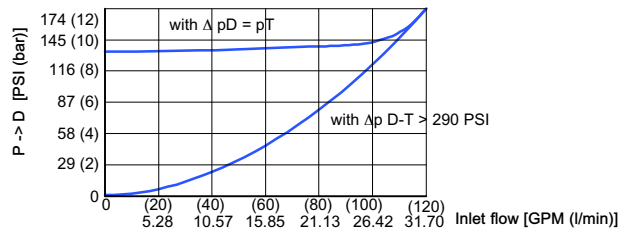

4.3.4.2 Maximum flow rate at directional valve (without individual pressure compensator) when using an LU8SSBU / LU8SSBW

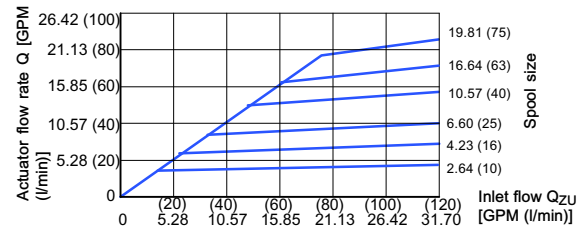

4.3.4.3 Pressure relief characteristic LU8SSB

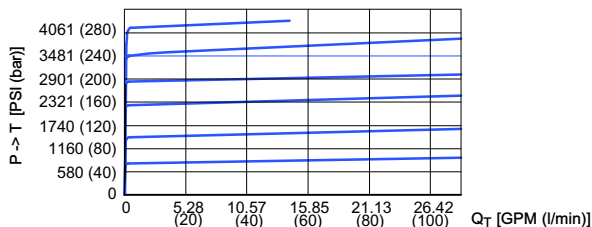

4.3.4.4 Unloaded pressure in neutral position, LU8SSBU / LU8SSBK

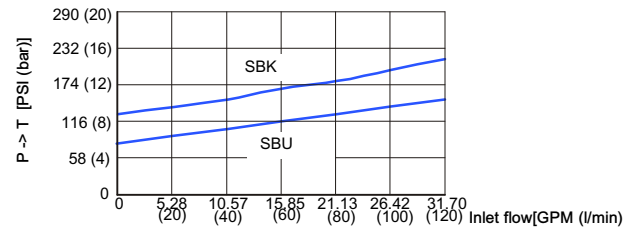

4.3.5 Overview of sections

Symbol	Description	Part number
	LU8SSBU-0U78 P= <ul style="list-style-type: none"> with two-stage pressure relief / control $\Delta p = 174$ PSI (12 bar) reduction in the unloaded pressure to approx. 87 PSI (6 bar) port threads to ISO 11926: 7/8"-14 UNF-2B ⇒ Specify the pressure relief setting in bar	-
	LU8SSBW-0U78 P= <ul style="list-style-type: none"> with two-stage pressure relief / with surplus flow port control $\Delta p = 174$ PSI (12 bar) port threads to ISO 11926: 7/8"-14 UNF-2B ⇒ Specify the pressure relief setting in bar	-
	LU8SSBW-0U78G12 P= <ul style="list-style-type: none"> with two-stage pressure relief / with surplus flow port control $\Delta p = 174$ PSI (12 bar) / emergency stop function port threads to ISO 11926: 7/8"-14 UNF-2B connector socket to DIN 43650 / nominal voltage 12 VDC ⇒ Specify the pressure relief setting in bar	-
	LU8SSBW-0U78T24 P= <ul style="list-style-type: none"> with two-stage pressure relief / with surplus flow port control $\Delta p = 174$ PSI (12 bar) / emergency stop function port threads to ISO 11926: 7/8"-14 UNF-2B plug type to DIN 43650 (others on request) / nominal voltage 24 VDC ⇒ Specify the pressure relief setting in bar	-
	LU8SSBK-0U78 <ul style="list-style-type: none"> compensator can be disabled for LS systems control $\Delta p = 174$ PSI (12 bar) with active pressure compensator without pressure relief port threads to ISO 11926: 7/8"-14 UNF-2B 	-

4.3.6 Connector socket

GDM plug to DIN 43650 G	AMP Junior Timer J	Deutsch plug DT04-2P-EP04 T

4.3.7 Dimensions [in (mm)]

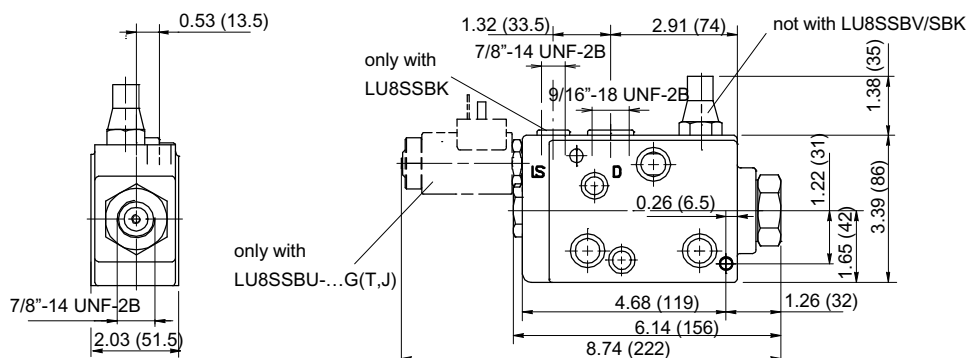

4.4 Intermediate sections with priority function

4.4.1 Description

The LU8SSB-0... priority sections contain a priority function for the directional valves fitted on the appropriate side or for an external control system and a surplus flow side.

In a under-supply scenario (pump flow < total flow needed by the valve block), the surplus flow side will receive only a portion of what it needs, or possibly (pump flow < priority-flow setting) no flow what ever. Preferred applications are in LS-systems. The priority side can also be equipped with a pressure relief valve that ensures a priority-flow cut-off when the pressure setting is reached.

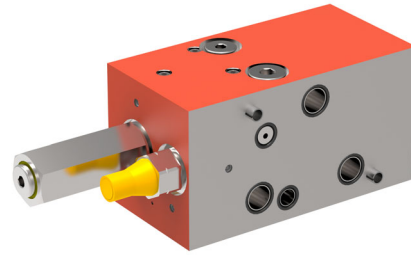

For oscillation-prone applications, a damping element (e.g. an accumulator) can be connected to a port specially (M14x1,5) provided for this purpose.

4.4.2 Technical data

General characteristics	Unit	Description, value
Inlet pressure	PSI (bar)	max. 4351 (max. 300)
Nominal flow rate	GPM (l/min)	31.7 (120)
Unloaded pressure P → T	PSI (bar)	see performance graphs 4.4.3
Pressure for flow cut-off (P _{Priority})	PSI (bar)	adjustable, 725 ... 4351 (50 ... 300)

4.4.3 Performance graphs

4.4.3.1 Flow cut-off on the priority side

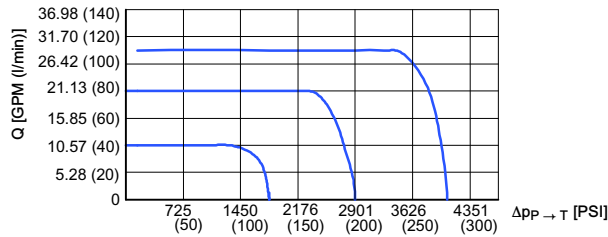

4.4.3.2 Pressure drop characteristic

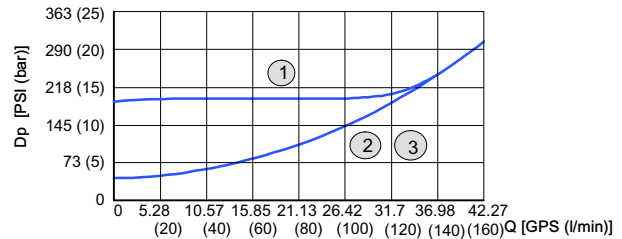

1	P _{pump port} to P _{Surp} (Q _{Priority} = zero) at P _{surp} =P _{LS}
2	P _{pump port} to P _{Surp} at Δp P _{Surp} to LS >290 PSI (20 bar)
3	P _{pump port} to P _{priority} (control spool in neutral position)

4.4.4 Overview of sections

Symbol	Description	Part number
	LU8SSBP-0U11 P= <ul style="list-style-type: none"> with flow cut-off / port threads to ISO 11926: 1 1/16"-12 UN-2B ⇒ Specify the pressure relief setting in bar, (50 - 300bar)	-
	LU8SSBP-0U15 P= <ul style="list-style-type: none"> with flow cut-off / port threads to BSP 1" ⇒ Specify the pressure relief setting in bar, (50 - 300bar)	-

4.4.5 Dimensions [in (mm)]

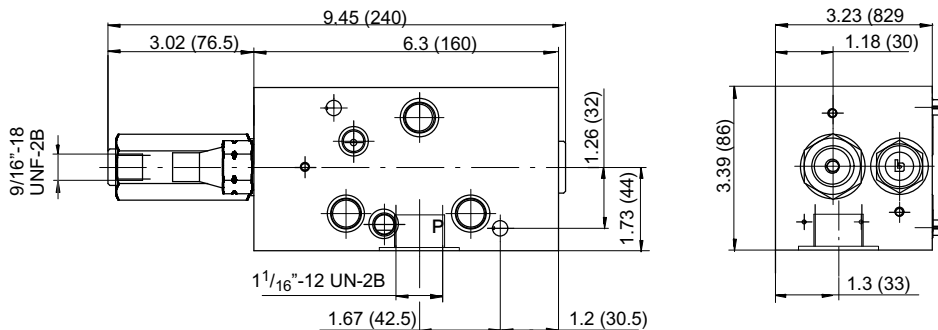

4.5 Intermediate sections with multi-way pressure compensator

4.5.1 Description

The multi-way pressure compensators contain a priority function for the directional valves fitted on the appropriate side. For the surplus-flow side, a 3-way pressure compensator is available for unloading control and load-independent flow control when using a fixed displacement pump.

In the under-supply range (pump flow < total flow needed by the valve block), the surplus flow side will receive only a portion of what it needs, or possibly (pump flow < priority flow setting) no flow whatsoever.

Application preferably in conjunction with a fixed displacement pump, but with the ability to change over to LS or constant-pressure systems.

Ports P, T, and LS are provided.

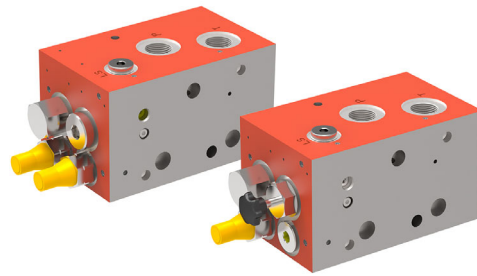

4.5.2 Functions

- **LU8SSMD**

Priority-flow control as 2- and 3-way compensator, with surplus-flow control as 3-way compensator. The priority-flow side is provided with a flow cut-off function, the surplus-flow side with two-stage pressure relief.

- **LU8SSMF**

Priority-flow control as 2- and 3-way compensator, with surplus-flow control as 3-way compensator. The priority-flow side is provided with a flow cut-off function. The surplus-flow control can be de-activated, which allows an LS- or constant-pressure system to be connected. This is typical with towed harvesters.

4.5.3 Technical data

General characteristics	Unit	Description, value
Inlet pressure	PSI (bar)	max. 4351 (max. 300)
Nominal flow rate	GPM (l/min)	31.7 (120)
Unloaded pressure	PSI (bar)	see performance graphs section 4.5.4
Pressure for flow cut-off (P_{Priority})	PSI (bar)	adjustable, pressure range 725 ... 4351 PSI (50 ... 300 bar)
Pressure for pressure relief (P_{Surp})	PSI (bar)	adjustable, pressure range 725 ... 4351 PSI (50 ... 300 bar)

4.5.4 Performance graphs

4.5.4.1 Maximum flow rate at directional valve when using an LU8SSM. (priority- and surplus side).

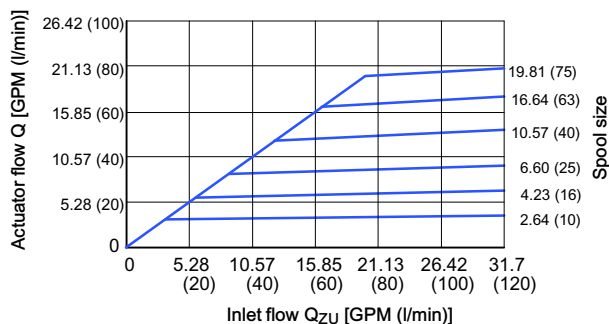

4.5.4.2 Flow cut-off on the priority side

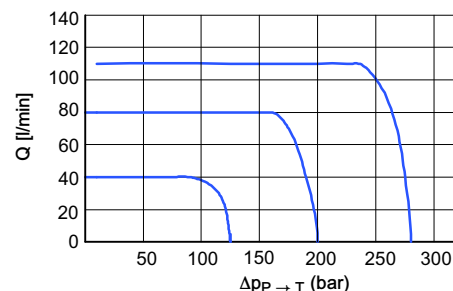

4.5.4.3 Pressure relief characteristic (priority and surplus flow) intermediate section LU8SSM

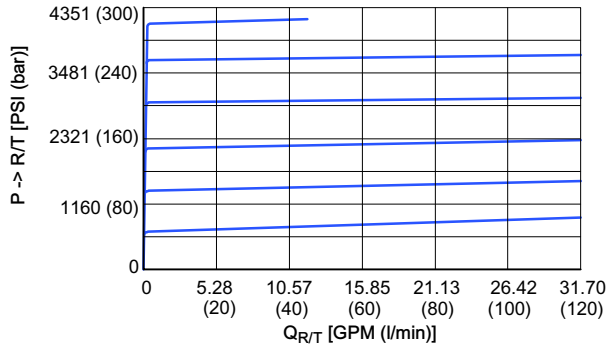

4.5.4.4 Unloaded pressure in neutral position intermediate section LU8SSM

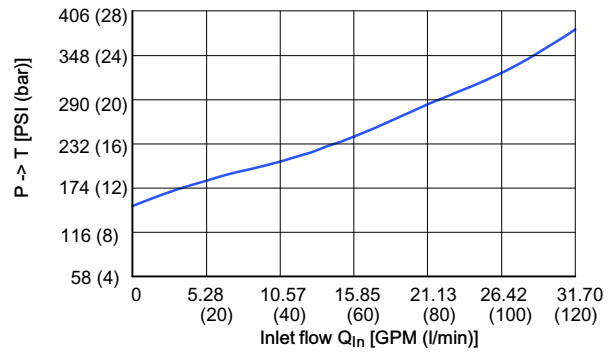

4.5.5 Overview of sections

Symbol	Description	Part number
	LU8SSMD-0U78 P1= P= <ul style="list-style-type: none"> • P_{Prior} with two-stage pressure relief • P_{Rest} with two-stage pressure relief • control $\Delta p = 174 \text{ PSI (12 bar)}$ for P_{Prior} and P_{Rest} • port threads to ISO 11926: 7/8"-14 UNF-2B ⇒ Specify the pressure relief setting in bar	100027461
	LU8SSMF-0U78 P= <ul style="list-style-type: none"> • P_{Prior} with pressure relief • compensator can be disabled on surplus-flow side for LS systems • control $\Delta p = 174 \text{ PSI (12 bar)}$ for P_{Prior} • control $\Delta p = 174 \text{ PSI (12 bar)}$ for P_{Rest} with active pressure compensator • port threads to ISO 11926: 7/8"-14 UNF-2B ⇒ Specify the pressure relief setting in bar	-

4.5.6 Dimensions [in (mm)]

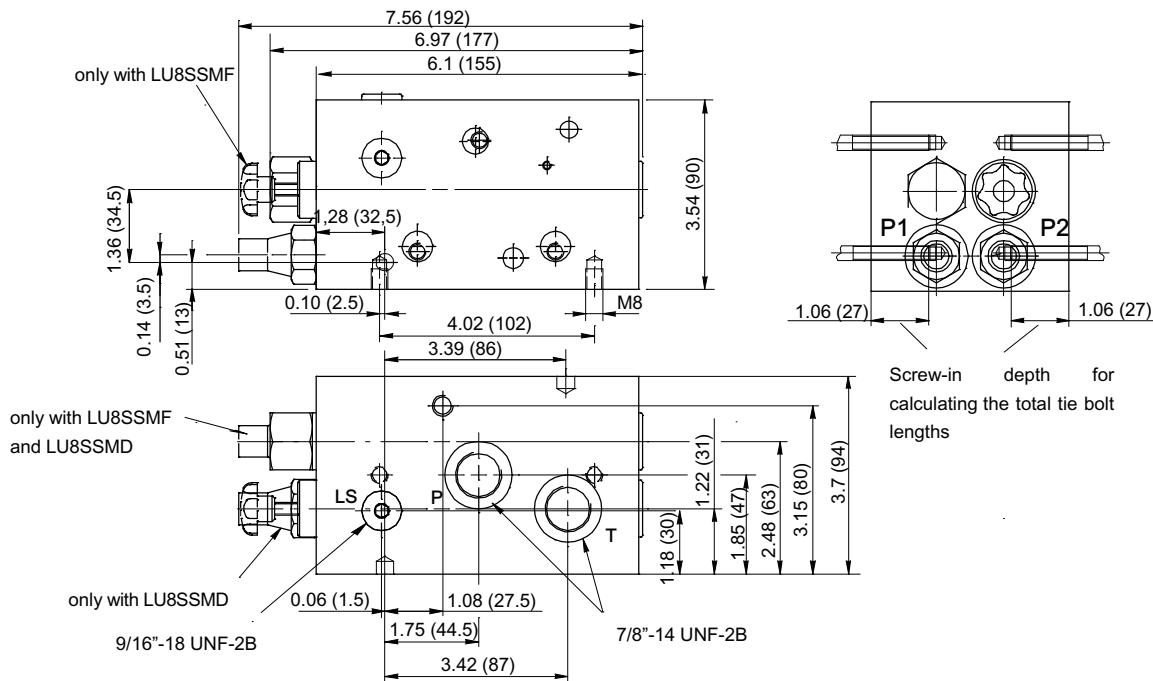

4.6 Intermediate section with proportional pressure reducing valve

4.6.1 Description

The 3-way pressure reducing valve holds the pressure at the actuator port at a constant level, as set by the solenoid current. Via the LS-feedback, this function can work with all pressure compensators and pump systems. The relevant additional functions are described below.

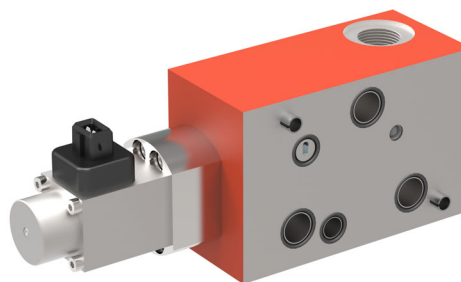

4.6.2 Functions

- LU8SPDRZ*06AS-..
3-way pressure reducing valve, minimum actuator pressure 116 ... 290 PSI (8...20 bar).
- LU8SPDRZ*06BS-..
3-way pressure reducing valve, minimum actuator pressure 116 ... 290 PSI (8...20 bar), has a seat valve for leak-free shut-off of the load.

4.6.3 Technical data

General characteristics	Unit	Description, value
Primary pressure P_{max}	PSI (bar)	max. 4351 (max. 300)
Secondary pressure P_{Red} (as per pressure range)	PSI (bar)	580 (40), 1450 (100), 2321 (160), 3626 (250)
Nominal flow rate Q_{max}	GPM (l/min)	10.57 (40) for LU8SPDRZ*06BS 6.6 (25) for LU8SPDRZ*06CS
Port thread		ISO 11926: $\frac{3}{4}$ "-16 UNF-2B
Power consumption: pressure reducing valve solenoid x	Watt	20 27
Nominal voltage pressure reducing valve	VDC	12 (24 on request)
Solenoid current I_{min} I_{max}	A	0.25 or 0,13 $\pm 10\%$ 1.90 or 0,95 $\pm 10\%$
Enclosure protection		AMP, GDM: IP65 DT: IP67 (DIN EN 60529)
Connector socket		DIN 43650

4.6.4 Performance graphs

4.6.4.1 Control characteristic $P_{reduced} = f(I_{solenoid})$

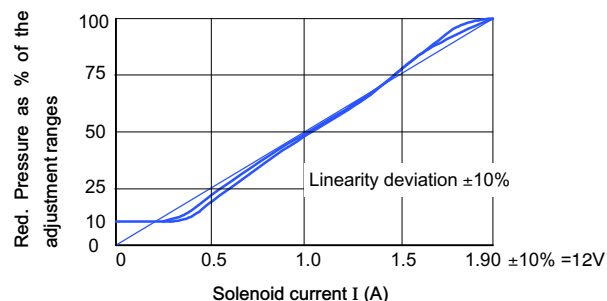

4.6.4.2 Adjustment ranges 3-way pressure control valve

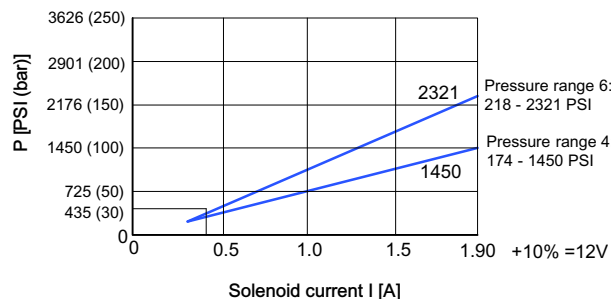

4.6.4.3 Control characteristic as a function of the flow rate

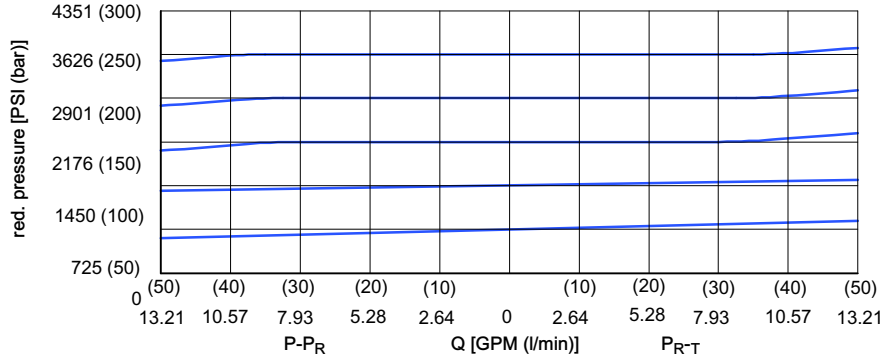

4.6.5 Overview of sections

Symbol	Description	Part number
	LU8SPDRZ*-06AS4-0U78G12/01 <ul style="list-style-type: none"> • solenoid operated • pressure range 174...1450 PSI (12...100 bar) • port threads to ISO 11926: 7/8"-14 UNF-2B 	-
	LU8SPDRZ*-06AS6-0U78G12/01 <ul style="list-style-type: none"> • solenoid operated • pressure range 218...2321 PSI (15...160 bar) • port threads to ISO 1192: 7/8"-14 UNF-2B 	-
	LU8SPDRZ*-06BS6-1U78G1212 <ul style="list-style-type: none"> • with seat valve on actuator side: Q_{max} 6,6 GPM (25 l/min) • solenoid operated • pressure range 218...2321 PSI (15...160 bar) • port threads to ISO 11926: 7/8"-14 UNF-2B • nominal voltage 2/2 seat valve 12 VDC 	-

4.6.6 Connector socket

GDM plug to DIN 43650 G	AMP Junior Timer J	DT04-2P-EP04 T

4.6.7 Dimension [in (mm)]

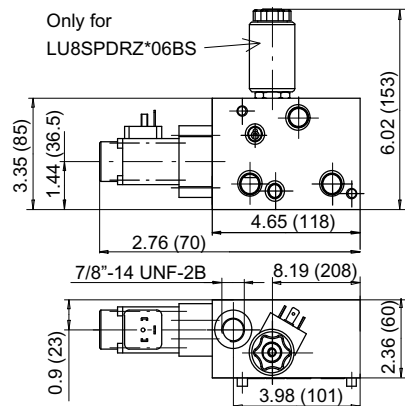

5 Directional valves

5.1 LA8S-/LF8S- Directional valve

5.1.1 Description

These directional valve sections, operated by hand lever or remote cable, are distinguished by their adaptability. Auxiliary functions can be bolted on above the valve. To enable this, the appropriated interfaces must be chosen (see the following illustrations).



5.1.1.1 Integral auxiliary functions

- Individual pressure compensator

The integral 2-way pressure compensator maintains a constant pressure differential over the metering orifice in the directional valve spool. This means that the corresponding actuator flow remains constant and load-independent even if another actuator that needs a higher pressure is operated at the same time.

- Flow cut-off

Thanks to the adjustable maximum pressure, the actuator flow rate is reduced to zero when the level is exceeded. The corresponding function therefore stops until the actuator pressure has fallen to the permissible pressure range.

5.1.2 Function

5.1.2.1 LA8S

Operated by hand lever



5.1.2.2 LF8S

Operated by remote cable



5.1.3 Technical data

General characteristics	Unit	Description, value
Inlet pressure	PSI (bar)	max. 4351 (300)
Actuator pressure duty cycle = 10 s/min	PSI (bar)	max. 4568 (315)
Spool size	GPM (l/min)	2.64 (10), 4.23 (16), 6.60 (25), 10.57 (40), 15.85 (60) ¹⁾
Operating force on the spool	lbf (N)	38 ... 47 (170 ... 210)

1) Higher flow rates on enquiry.

5.1.4 Overview of sections

Symbol	Description	Part number
	L.8SE.....-.*O-.... <ul style="list-style-type: none"> • port thread for actuator A and B 	see ordering code
	L.8SE.....-MO-.... <ul style="list-style-type: none"> • for bolt-on auxiliary valves on flange face O 	see ordering code

	<p>L.8SM.....-*I-....</p> <ul style="list-style-type: none"> with port thread for actuator A and B integrated pressure compensator 	<p>see ordering code</p>
	<p>L.8SM.....-MI-....</p> <ul style="list-style-type: none"> for bolt-on auxiliary valves on flange face O integrated pressure compensator 	<p>see ordering code</p>
	<p>L.8SM.....-F*L-....</p> <ul style="list-style-type: none"> with port thread for actuator A and B spring return, flow cut-off integrated pressure compensator 	<p>see ordering code</p>
	<p>L.8SM.....-FML-....</p> <ul style="list-style-type: none"> for bolt-on auxiliary valves on flange face O spring return, flow cut-off integrated pressure compensator 	<p>see ordering code</p>

5.1.5 Performance graphs

5.1.5.1 Maximum flow rate at directional valve (without compensator), LS function

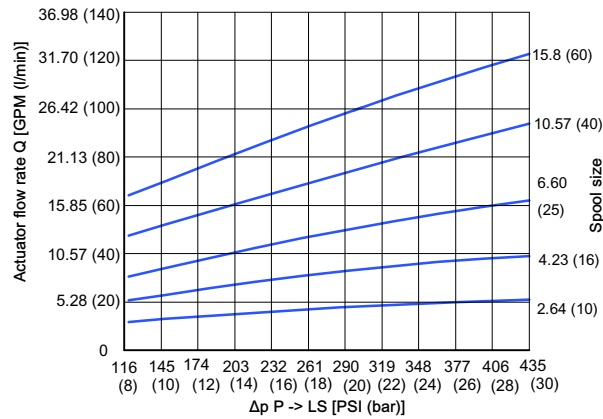

5.1.5.3 Pressure drop A/B → T

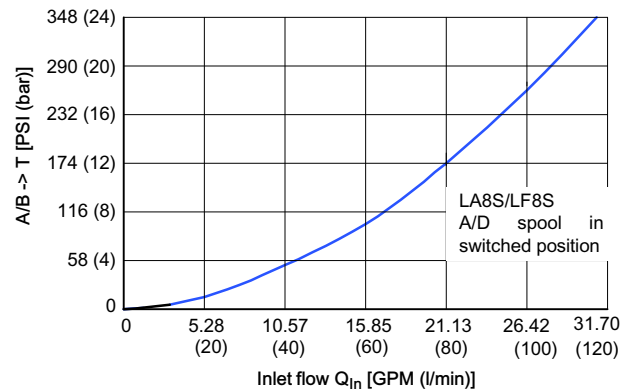

5.1.5.2 Flow characteristic with individual pressure compensator at flange face U

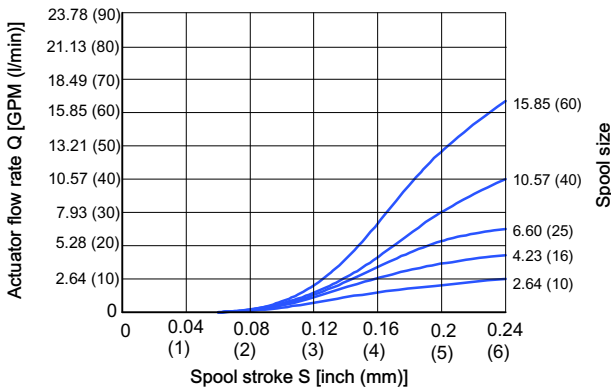



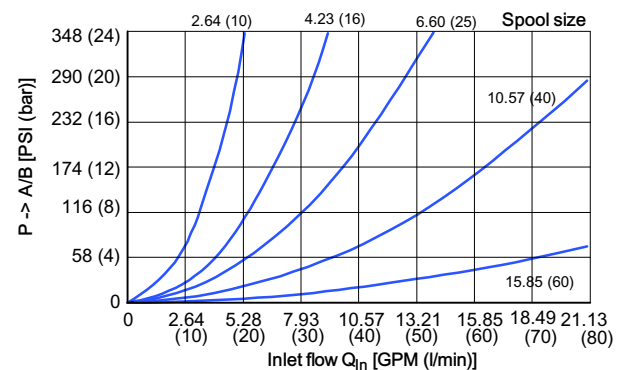



5.1.5.4 Pressure drop P → A/B (L.8S directional valve), without pressure compensator, spool at maximum stroke

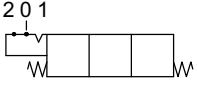
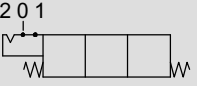
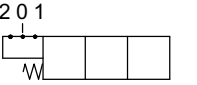
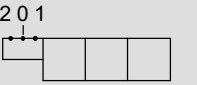
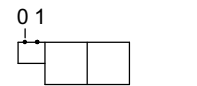
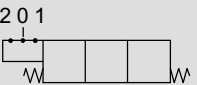
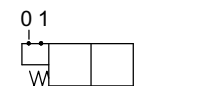

5.1.6 Overview spool position control

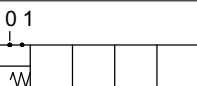
The purpose of the spool position controls and their variants is to optimise the spool-operation logic, and they should be

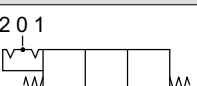
employed to make the user's task simpler. The various types are described below.

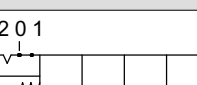
Spool position control type	Spring return from switch position		Detent function in switch position			Friction detent in switch position	
	1	2	1	2	3	1	2
A 		√	√				
B 	√			√			
C 	√						√
D 						√	√
E 						√	
F 	√	√					
G 	√						
J 			√				
L 	√	√			√		
M 			√	√	√		
R 			√	√			
T 		√	√		√		
U 	√			√	√		



Spring return: The spool returns to position 0 automatically.

Detent function: The spool is held at position 0; at maximum stroke it is also held in the respective position.

Friction detent: A detent can be felt at position 0; at any other position a friction device restrains the spool.

5.1.7 Option menu for ordering code (ordering code see section 5.1.8)

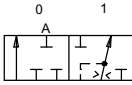
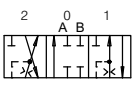
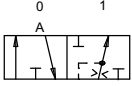
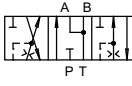
Spool type (way function, spool function, spool size in GPM (l/min))

 <p>3I</p>	<p>2.64 GPM (10 l/min) 4.23 GPM (16 l/min) 6.60 GPM (25 l/min) 10.57 GPM (40 l/min) 15.85 GPM (60 l/min)</p>	 <p>4A</p>	<p>2.64 GPM (10 l/min) 4.23 GPM (16 l/min) 6.60 GPM (25 l/min) 10.57 GPM (40 l/min) 15.85 GPM (60 l/min)</p>
 <p>3J</p>	<p>2.64 GPM (10 l/min) 4.23 GPM (16 l/min) 6.60 GPM (25 l/min) 10.57 GPM (40 l/min) 15.85 GPM (60 l/min)</p>	 <p>4D</p>	<p>2.64 GPM (10 l/min) 4.23 GPM (16 l/min) 6.60 GPM (25 l/min) 10.57 GPM (40 l/min) 15.85 GPM (60 l/min)</p>
		 <p>4K</p>	

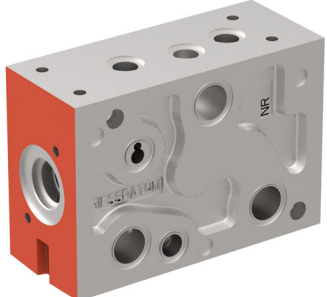

Control type	
hand lever	= LA8S
remote cable	= LF8S
Operation	
load-independent individual operation	= E
load-independent parallel operation	= M
Attachment to flange face O	
port threads for line connections	= *
flange face for auxiliary valve	= M
Compensator function:	
without pressure compensator	= O
with integrated pressure compensator	= I
with pressure compensator and flow cut-off	= L
Type of connection at face O	
Flange face to factory standard	= ***
Line connection to port A und B: ISO 11926: 3/4"-16 UNF-2B	= U34

5.1.8 Dimensions [in (mm)]

5.1.8.1 Switch positions LF8S

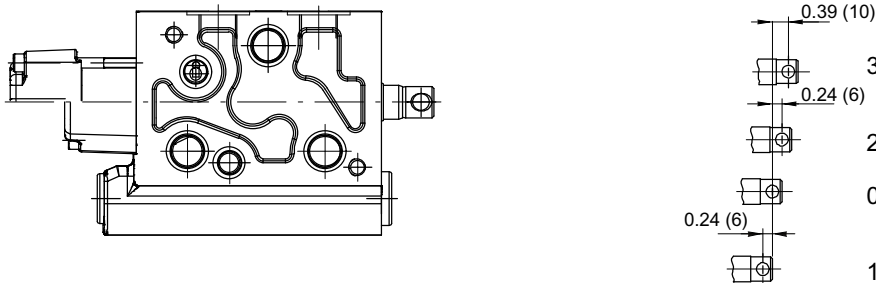

5.1.8.2 LF8S-directional valve

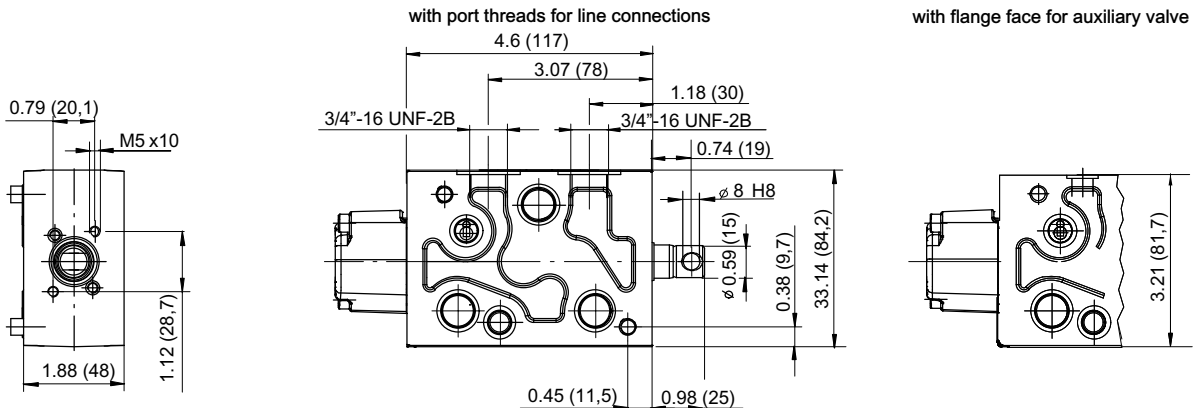

5.1.8.3 LF8S-directional valve with integrated pressure compensator

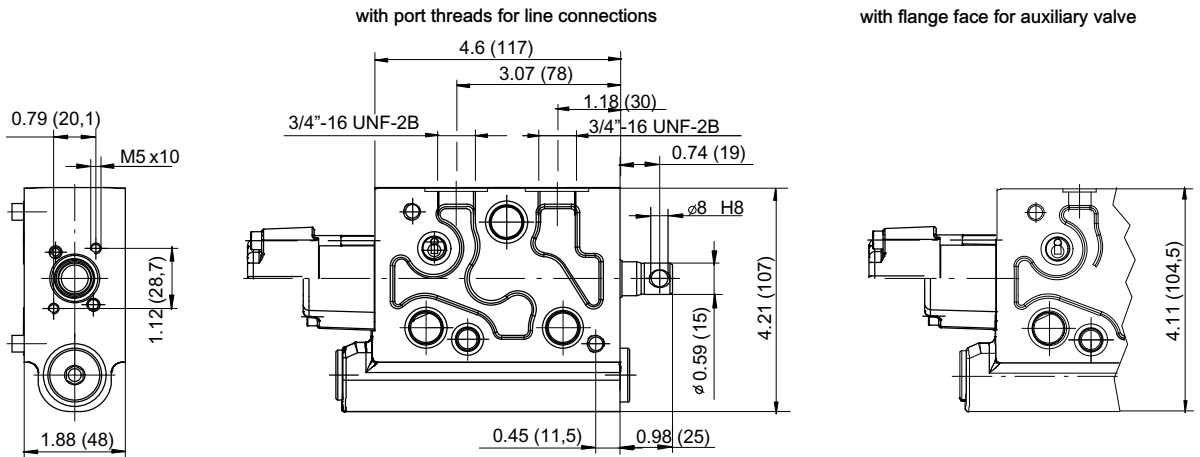

5.1.8.4 LA8S-directional valve

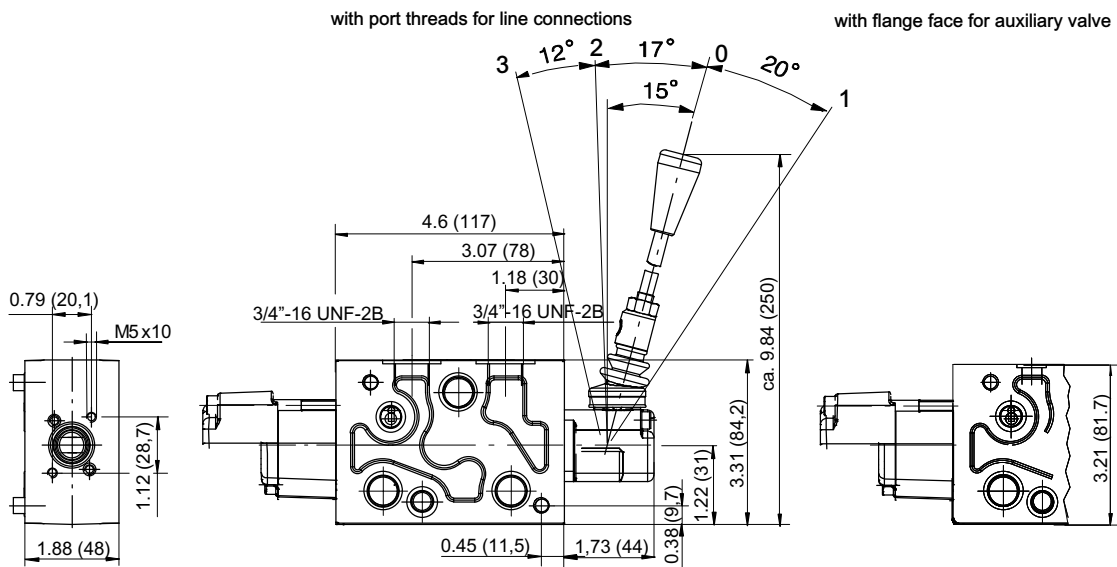

5.1.8.5 LA8S-directional valve with integrated pressure compensator

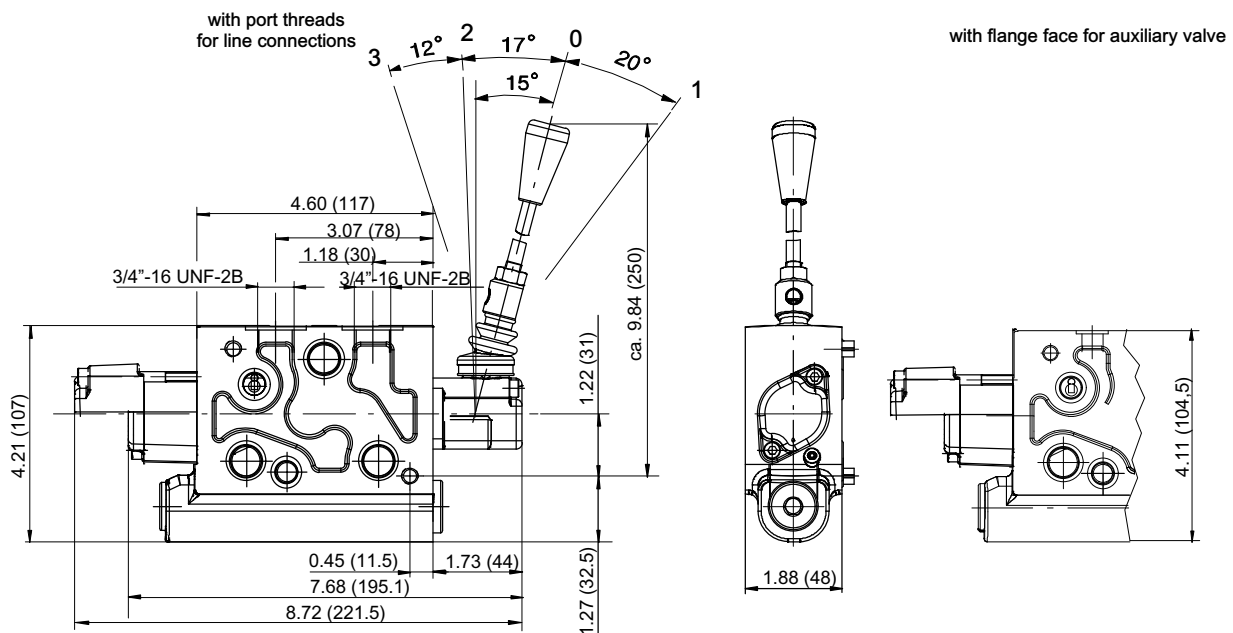

5.1.8.6 LA8S-directional valve with integrated pressure compensator and flow cut-off

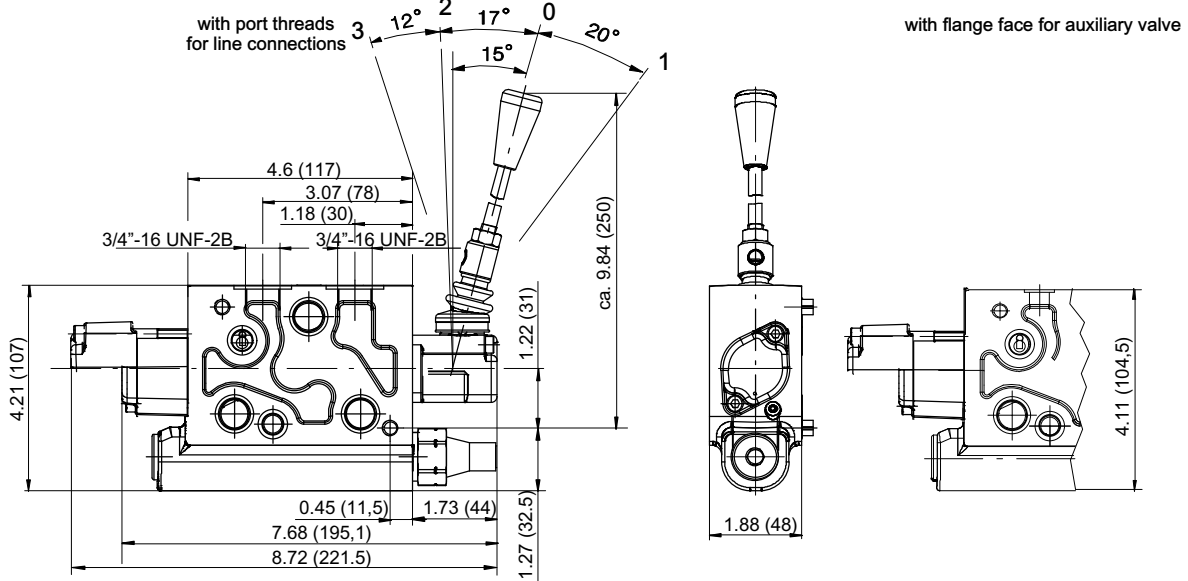

5.1.9 Ordering code LA8S... / LF8S...

- White fields = data specified by Bucher Hydraulics
- Grey fields = fill out the fields according the option menu 5.1.6 and the spool position overview 5.1.5

	L	A	8	S	E	4	A	1	0	1	0	-	F	*	O	-	0	U	3	4	/	
Hand lever	= LA8S																					
Remote operation	= LF8S 1)																					
Load-independent individual operation					= E																	
Load-independent parallel operation					= M																	
3-way function					= 3																	
4-way function					= 4																	
Spool function					= A, D, I, J, K																	
Port A spool code:																						
					10 (2.64 GPM), 16 (4.23 GPM), 25 (6.60 GPM)																	
					40 (10.57 GPM), 63 (16.64 GPM), 75 (19.81 GPM) ²⁾																	
					= e.g. 10																	
Port B spool code:																						
with 3-way function					= **																	
with 4-way function:																						
					10 (2.64 GPM), 16 (4.23 GPM), 25 (6.60 GPM); 40 (10.57 GPM),																	
					63 (16.64 GPM), 75 (19.81 GPM) ²⁾																	
					= e.g. 10 1)																	
Spool position control (overview see section 5.1.5)					= e.g. A																	
Attachment to connection face O:																						
port threads for line connection					= *																	
flange face for auxiliary valves					= M																	
Compensator function:																						
without pressure compensator					= O																	
with integrated pressure compensator					= I																	
with pressure compensator and flow cut-off					= L																	
Design stage (to be inserted by Bucher Hydraulics)																						
Type of connection at face O:																						
flange face to factory standard					= ***																	
line connection to port A and B: ISO 11926: 3/4"-16 UNF 2B					=U34																	
Option (to be inserted by Bucher Hydraulics)																						

1) By cultivation the cable operating 200.9609.0003.0 the special design LF8S.../17 must be selected.

2) For higher flow rates, please enquire.

5.2 LD8S- /LC8S-Directional valve

5.2.1 Description

These directional valve sections with direct-acting ON/OFF solenoid or proportional solenoid are distinguished by their adaptability. Auxiliary functions can be bolted on above or below the valve. To enable this, the appropriate interfaces must be chosen (see following illustrations).

It is possible to set either the opening point of the control spool, or any predetermined point on the characteristic. In the version with an additional manual operator, the flow rate can be increased.

The setting of the additional manual operator has no effect on the electrical operation. During electrical operation, the additional manual operator is not carried along with the solenoid mechanism. The lever remains in its neutral position, and thus has no influence on the spool characteristic.



5.2.1.1 Integral auxiliary functions

- **Individual pressure compensator**

The integral 2-way pressure compensator maintains a constant pressure differential over the metering orifice in the directional valve spool. This means that the corresponding actuator flow remains constant and load-independent even if another actuator that needs a higher pressure is operated at the same time.

- **Flow cut-off**

Thanks to the adjustable maximum pressure, the actuator flow rate is reduced to zero when the level is exceeded. The corresponding function therefore stops until the actuator pressure has fallen to the permissible pressure range.

The pressure adjustment is manual, or optionally electro-proportional.

- **3-way pressure control**

Both a 3-way pressure control (P constant) and a flow control (Q constant) are incorporated in this valve section. The integral pressure control function can be switched to actuator port A or B, depending on the switching position of the valve section.

Below the pressure setting, the pressure-control assembly works as an individual pressure compensator and maintains a constant pressure differential over the metering orifice in the directional valve spool.

This means that the actuator flow rate is load-independent. For optimum 3-way pressure control, the corresponding directional function must be activated to its maximum extent.

Typical applications are actuating functions that are specifically speed-controlled, with the possibility of a holding or press function. This function can be controlled to any required pressure and can act optionally on either actuator A or B.

5.2.2 Function

5.2.2.1 LD8S with direct-acting ON/OFF solenoid



5.2.2.2 LD8S with direct-acting ON/OFF solenoid, optional manual override for the valve spool

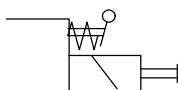

The flow rates to the A and B actuator ports are graded by spool size as per sections 5.2.4. Using the stop-screw on the non-active solenoid, each flow rate can be reduced from its maximum by a maximum of 50%.

5.2.2.3 LC8S with direct-acting proportional solenoid

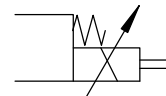

5.2.2.4 LC8S with direct-acting proportional solenoid, optional manual override for the valve spool

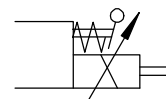

The flow rates to the A and B actuator ports are graded by spool size as per sections 5.2.4.

5.2.3 Technical data

General characteristics	Unit	Description, value	
		LD8S	LC8S
Type of operation	PSI (bar)	ON/OFF	Proportional
Inlet pressure	PSI (bar)	3626 (250)	
Actuator pressure (duty cycle 10 sec/min)	PSI (bar)	max. 4061 (max. 280)	
Spool size	GPM (l/min)	0.53 (02) / 1.32 (05) / 2.64 (10) / 4.23 (16) / 6.6 (25) / 10.57 (40) / 15.85 (60)	
Solenoid design		ON/OFF solenoid with mechanical manual override	Proportional solenoid with mechanical manual override
Nominal voltage	VDC	12 (10.8 ... 14) 24 (21.6 ... 28)	12 or 24
Power consumption at R ₂₀	Watt	22 (U _N 12 V) 22 (U _N 24 V)	max. 24 at 2.5 A (U _N 12 VDC) max. 24 at 1.3 A (U _N 24 VDC)
Duty cycle	%	100	100 at I _{max} 2.5 A (U _N 12 VDC) 1.13 A (U _N 24 VDC)
Plug type		AMP Junior Timer with protective diode P6KE33CA, DT04-2P-EP04	
Enclosure protection		AMP: IP65	DT04-2P-EP04: IP67 (DIN EN 60529)
Switch frequency	Hz	> 2 (please contact the factory)	
Accessories			For electronic controls see overview brochure P70003

IMPORTANT: Maximum reduction is to 50% of the respective nominal spool size.

5.2.4 Performance graphs

5.2.4.1 Typical flow characteristic curve without compensator function (spool 4D)

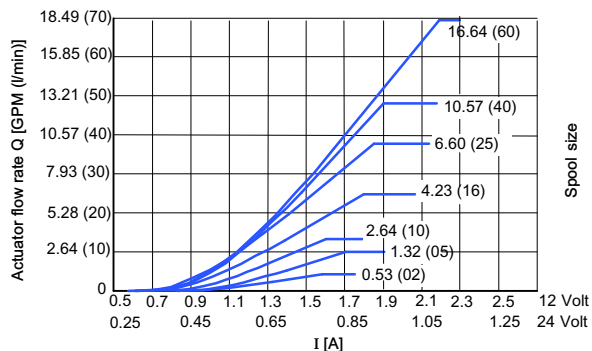

5.2.4.2 Typical flow characteristic curve with compensator function (spool 4D)
(Inlet section with 3-way pressure compensator for Δp 12 bar)

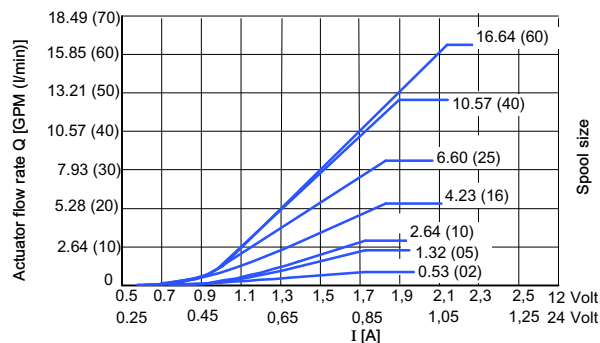

5.2.4.3 LD/LC
Maximum flow rate at the directional valve without compensator function, LS-function

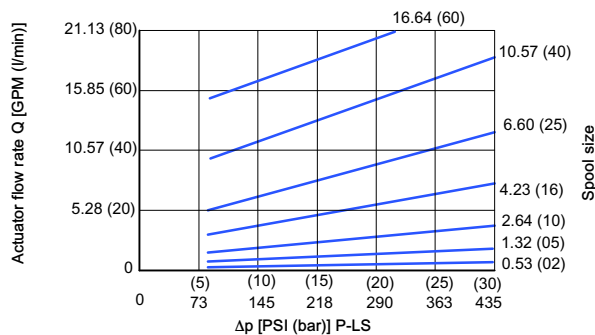

5.2.4.4 LC
Pressure drop A/B -> T in the LC8SM4A directional stage

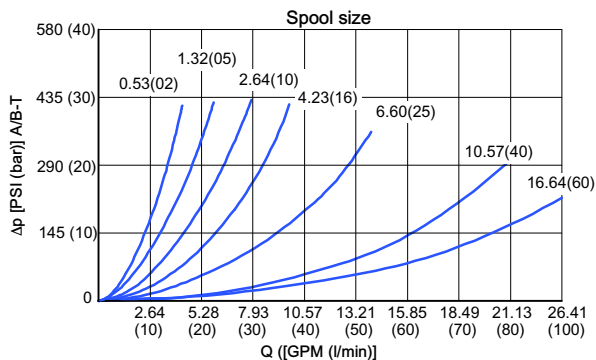

5.2.4.5 Typical flow characteristic curve with flow cut-off function, pressure relief adjustable (manual)

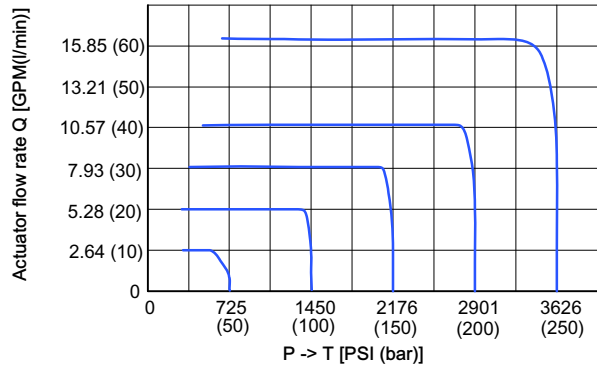

5.2.4.6 Typical flow characteristic curve with flow cut-off function, pressure relief adjustable (electr. prop.)

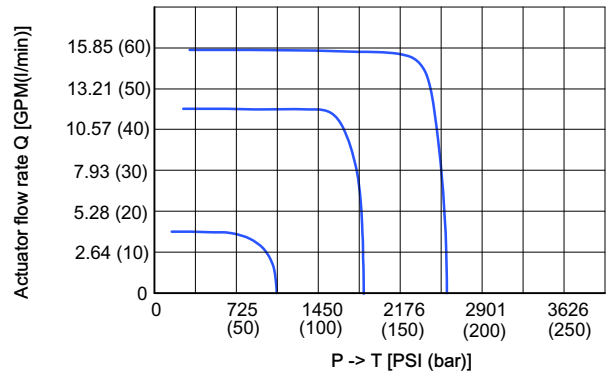

5.2.4.7 LC flow cut-off function pressure setting p - I (electr. prop.)

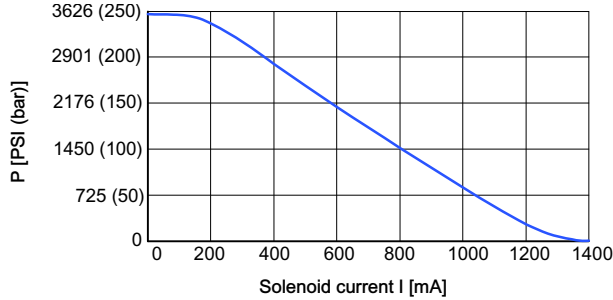

5.2.4.8 Typical pressure profile, 3-way pressure control Electroproportional

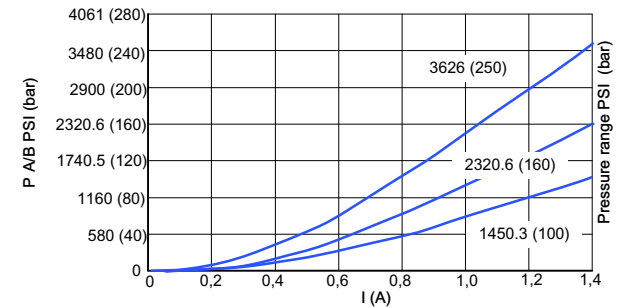

Inverse function possible – please enquire.

5.2.4.9 Typical pressure profile, 3-way pressure control, Overall function

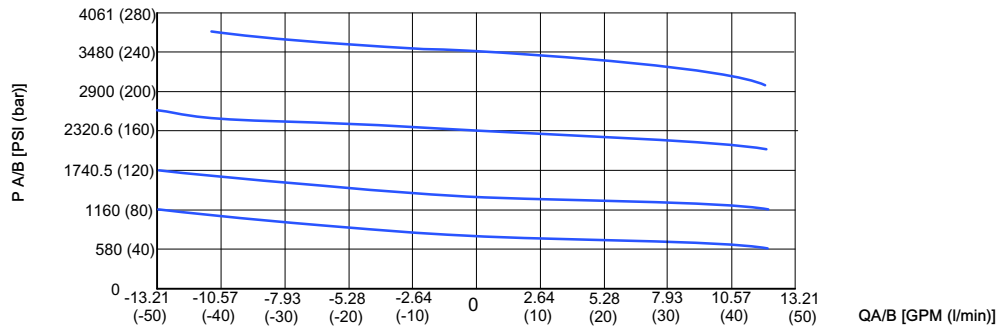

5.2.5 Overview of sections

5.2.5.1 LD8S / LC8S-directional valves with port threads

Symbol	Description	Part number
	L.8SE.....-.*O-.... <ul style="list-style-type: none"> port threads for actuator A and B 	see ordering code
	L.8SM.....-.*I-.... <ul style="list-style-type: none"> port threads for actuator A and B pressure compensator 	see ordering code

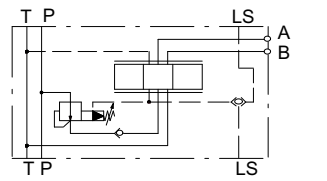
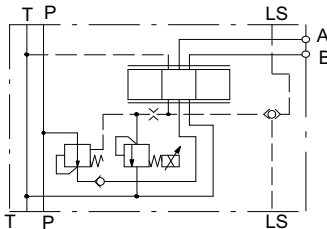
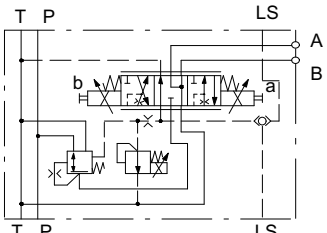
	<p>L.8SM.....-L-....</p> <ul style="list-style-type: none"> port threads for actuator A and B flow cut-off 	<p>see ordering code</p>
	<p>L.8SM.....-P-....</p> <ul style="list-style-type: none"> port threads for actuator A and B pressure compensator flow cut-off electroproportional 	<p>see ordering code</p>
	<p>L.8SM.....-4-....</p> <ul style="list-style-type: none"> port threads for actuator A and B pressure compensator 3-way pressure control 	<p>see ordering code</p>

5.2.5.2 LD8S / LC8S-directional valves for bolt-on auxiliary valves

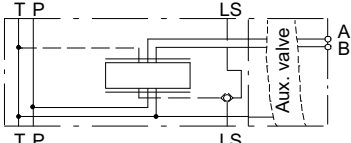
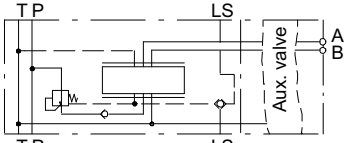
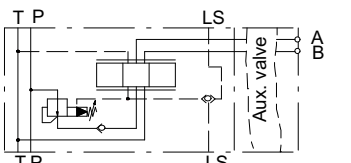
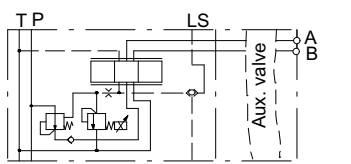
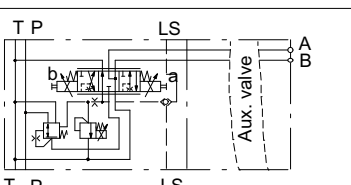
Symbol	Description	Part number
	<p>L.8SE.....-MO-....</p> <ul style="list-style-type: none"> for bolt-on auxiliary valves on flange face O 	<p>see ordering code</p>
	<p>L.8SM.....-MI-....</p> <ul style="list-style-type: none"> for bolt-on auxiliary valves on flange face O flow cut-off 	<p>see ordering code</p>
	<p>L.8SM.....-ML-....</p> <ul style="list-style-type: none"> for bolt-on auxiliary valves on flange face O pressure compensator flow cut-off 	<p>see ordering code</p>
	<p>L.8SM.....-MP-....</p> <ul style="list-style-type: none"> for bolt-on auxiliary valves on flange face O integrated individual pressure compensator flow cut-off, electroproportional 	<p>see ordering code</p>
	<p>L.8SM.....-M4-....</p> <ul style="list-style-type: none"> for bolt-on auxiliary valves on flange face O pressure compensator 3-way pressure control 	<p>see ordering code</p>

5.2.6 Option menu for ordering code (ordering code see section 5.2.9)

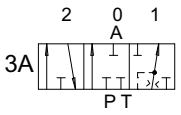
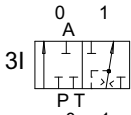
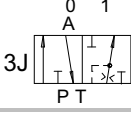
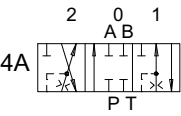
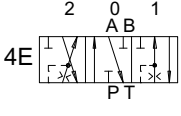
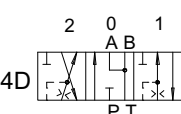
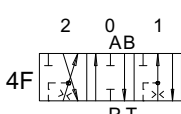

Spool type (way function, spool function, spool size in GPM (l/min))	
 <p>3A</p>	2.64 GPM (10 l/min) 4.23 GPM (16 l/min) 6.60 GPM (25 l/min) 10.57 GPM (40 l/min) 15.85 GPM (60 l/min)
 <p>3I</p>	1.32 GPM (05 l/min) 2.64 GPM (10 l/min) 4.23 GPM (16 l/min) 6.60 GPM (25 l/min) 10.57 GPM (40 l/min) 15.85 GPM (60 l/min)
 <p>3J</p>	1.32 GPM (05 l/min) 2.64 GPM (10 l/min) 4.23 GPM (16 l/min) 6.60 GPM (25 l/min) 10.57 GPM (40 l/min) 15.85 GPM (60 l/min)
 <p>4A</p>	0.53 GPM (02 l/min) 1.32 GPM (05 l/min) 2.64 GPM (10 l/min) 4.23 GPM (16 l/min) 6.60 GPM (25 l/min) 10.57 GPM (40 l/min) 15.85 GPM (60 l/min)
 <p>4E</p>	4.23 GPM (16 l/min) 6.60 GPM (25 l/min) 10.57 GPM (40 l/min) 15.85 GPM (60 l/min)
 <p>4D</p>	0.53 GPM (02 l/min) 1.32 GPM (05 l/min) 2.64 GPM (10 l/min) 4.23 GPM (16 l/min) 6.60 GPM (25 l/min) 10.57 GPM (40 l/min) 15.85 GPM (60 l/min)
 <p>4F</p>	2.64 GPM (10 l/min) 4.23 GPM (16 l/min) 6.60 GPM (25 l/min) 10.57 GPM (40 l/min) 15.85 GPM (60 l/min)



Control type	ON/OFF solenoid = LD8S	proportional solenoid = LC8S
Operation	load-independent individual operation = E	load-independent parallel operation = M
Additional operator	spool stroke limiter (only LD8S) = S	manual override = N
Attachment to connection face O	port threads for line connections = *	flange face for auxiliary valve = M
Compensator function	without pressure compensator = O	with pressure compensator = I
	with pressure compensator and flow cut-off = L	with pressure compensator, electr. proportional flow cut-off = P
	with pressure compensator and 3-way pressure control = 1	
	1 = up to 580 PSI (40 bar)	
	2 = up to 1450 PSI (100 bar)	
	3 = up to 2321 PSI (160 bar)	
	4 = up to 3626 PSI (250 bar)	
Type of connection at face O	flange face to factory standard = ***	line connection to port A and B: ISO 11926: 3/4"-16 UNF 2B = U34

Nominal voltage	12 V DC = 12	24 V DC = 24
Connector socket	AMP Junior Timer = J	DT04-2P-EP04 = T

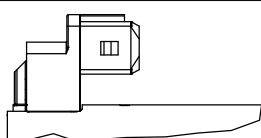
5.2.7 Connector socket

AMP Junior Timer with protective diode P6KE33CA J	DT04-2P-EP04 T
	

5.2.8 Dimensions [in (mm)]

5.2.8.1 LD8S / LC8S core tube

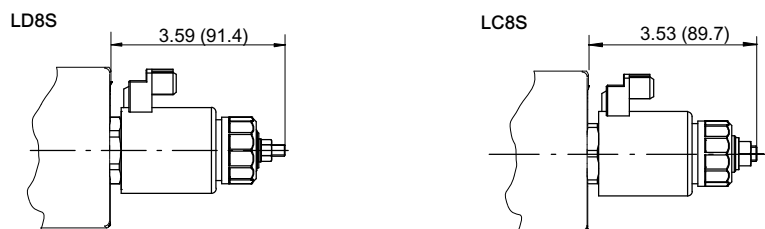

5.2.8.2 LD8S-directional valve

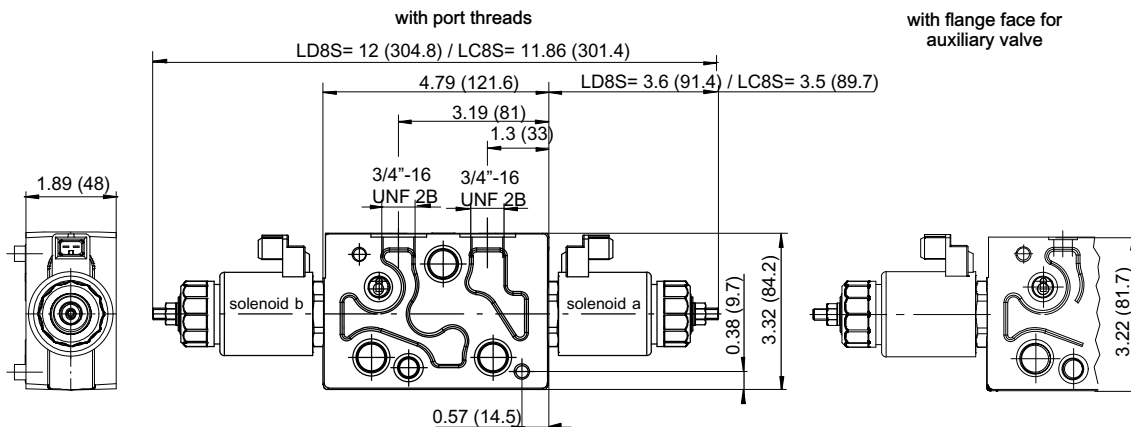

5.2.8.3 LD8SM / LC8SM-directional valve with integrated pressure compensator

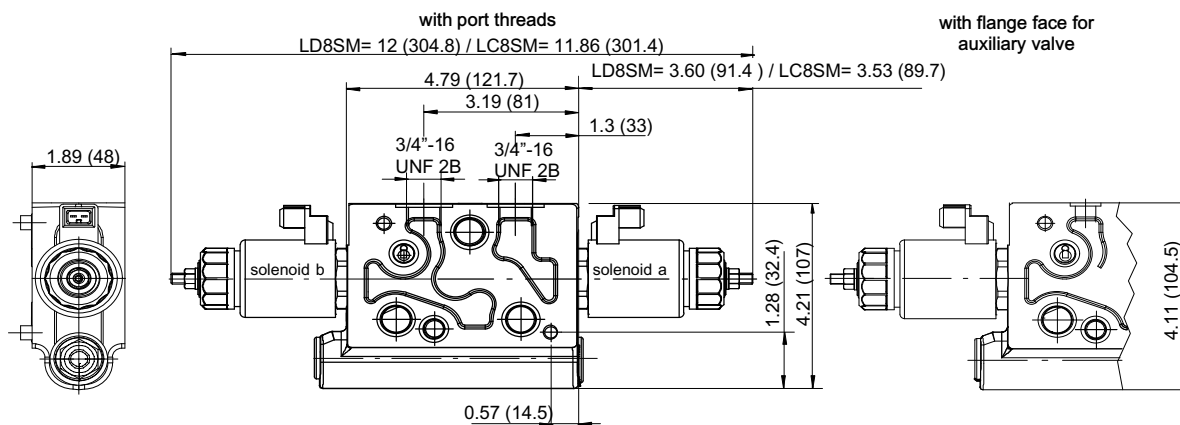

5.2.8.4 LD8S / LC8S-directional valve with integrated pressure compensator and flow cut-off

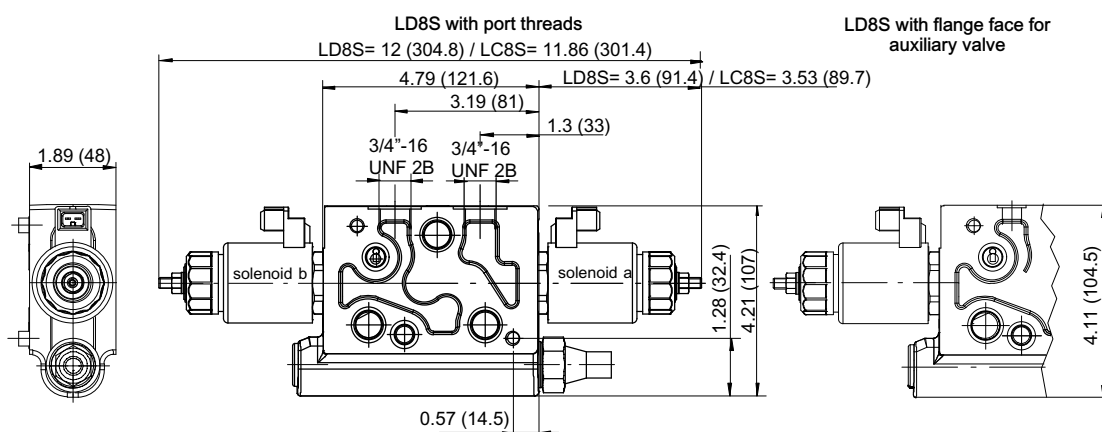

5.2.8.5 LD8S / LC8S-directional valve with manual override

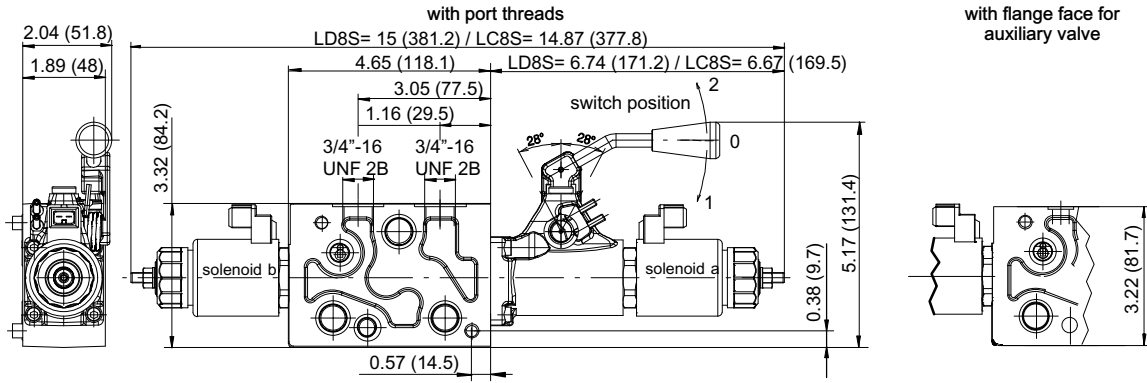

5.2.8.6 LD8S / LC8S-directional valve with manual override, pressure compensator and flow cut-off

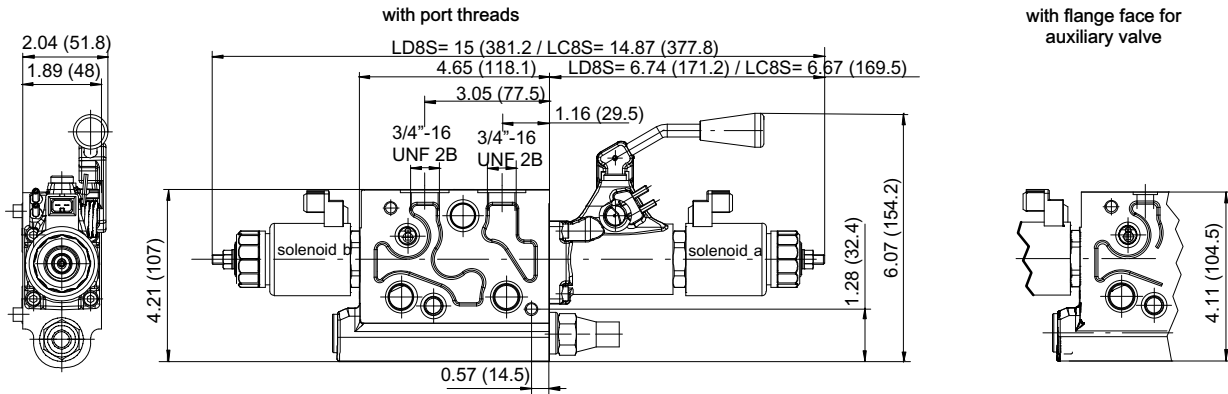

5.2.8.7 LD8S / LC8S-directional valve with pressure compensator, electrically-proportionally flow cut-off

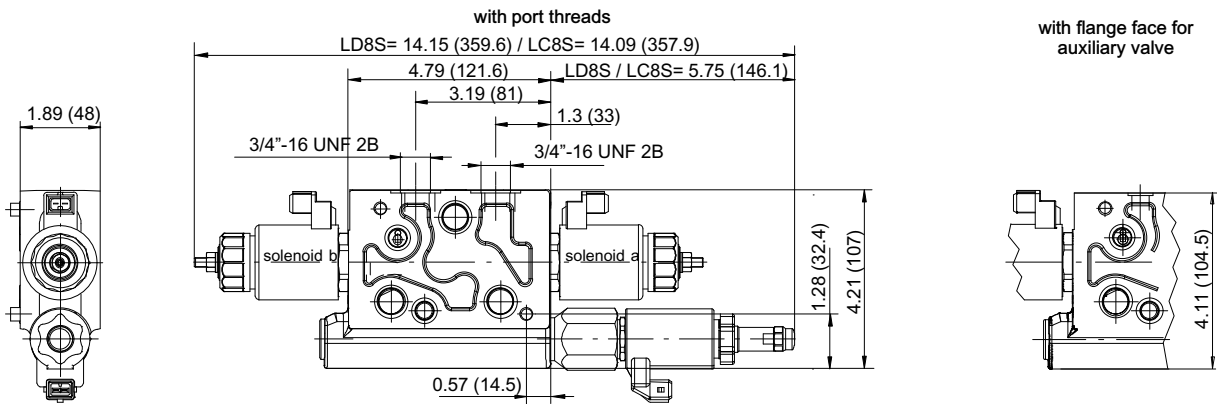

5.2.8.8 LD8S / LC8S-proportional valve with pressure compensator and 3-way pressure control

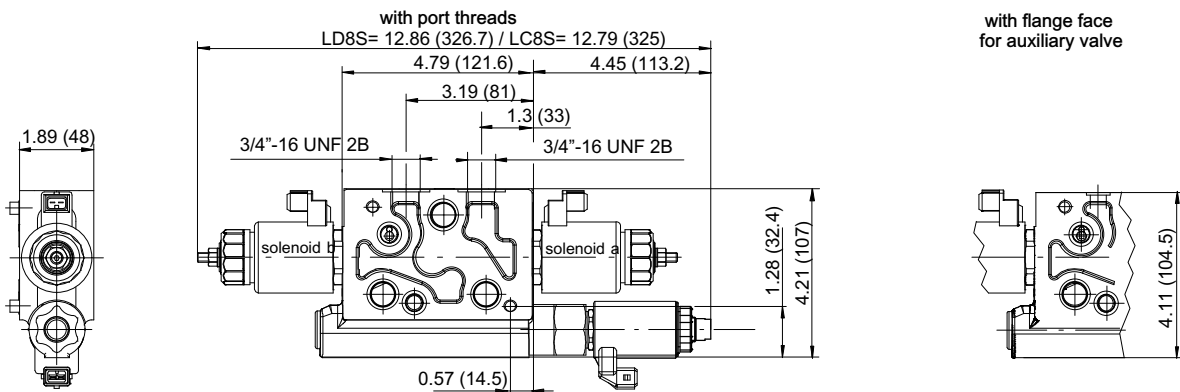

5.2.9 Ordering code

- White fields = data specified by Bucher Hydraulics
- Grey fields = fill out the fields according the option menu 5.2.6

	L	D	8	S	E	3	A	1	0	*	*	-	S	*	O	-	0	U	3	4	J	1	2	
ON/OFF solenoid = LD8S Proportional solenoid = LC8S																								
Load-independent individual operation = E Load-independent parallel operation = M																								
3-way function = 3 4-way function = 4																								
Spool function = A, D, E, F, I, J																								
Port A spool code: 02 (0.53 GPM), 05 (1.32 GPM) 10 (2.64 GPM), 16 (4.23 GPM), 25 (6.60 GPM) 40 (10.57 GPM), 60 (15.85 GPM) = e.g. 10																								
Port B spool code for 3-way function = ** for 4-way function: 02 (0.53 GPM), 05 (1.32 GPM), 10 (2.64 GPM), 16 (4.23 GPM) 25 (6.60 GPM), 40 (10.57 GPM), 60 (15.85 GPM) = e.g. 10																								
Additional operator: without additional operator (only for LC8S) = * spool stroke limiter (only for LD8S) = S manual override = N																								
Attachment to connection face O: port threads for line connection = * flange face for auxiliary valve = M																								
Compensator function: without pressure compensator = O with integrated pressure compensator = I with pressure compensator and flow cut-off = L with pressure compensator, electrically-proportionally flow cut-off = P with pressure compensator, 3-way pressure control (only up to 40 l/min) = e.g. 2 Information for pressure setting: 1 = up to 580 PSI (40 bar) 2 = up to 1450 PSI (100 bar) 3 = up to 2321 PSI (160 bar) 4 = up to 3626 PSI (250 bar)																								
Design stage (will be inserted by Bucher Hydraulics)																								
Type of connection at face O: flange face to factory standard = *** line connection to port A and B: ISO 11926: 3/4"-16 UNF 2B = U34																								
Connector socket: AMP Junior Timer = J Deutsch plug DT04-2P-EP04 = T																								
Nominal voltage: 12 V DC = 12 24 V DC = 24																								
Option: HPCO/Pressure Beyond for compatibility with 2/2 double-seat valve SVH04 (see chapter 11) = 02																								

5.2.10 Connector socket

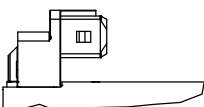
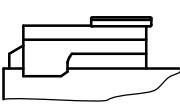
AMP Junior Timer with protective diode P6KE33CA J	Deutsch plug DT04-2P-EP04 T
	

5.3 LM8S-/LP8S- Directional valve

5.3.1 Description

These directional valve sections, with two-stage solenoid/hydraulic control, ON/OFF or proportional, are distinguished by their slim design and their adaptability. Auxiliary functions can be bolted on above or below the valve. To enable this, the appropriate interfaces must be chosen (see the following illustrations).

Manual overrides are available that act on the pilot stage, or directly on the main stage (non-following type). End-stops for the spool (special feature L.8S.../16) make it possible to limit the maximum actuator flow to any desired value.

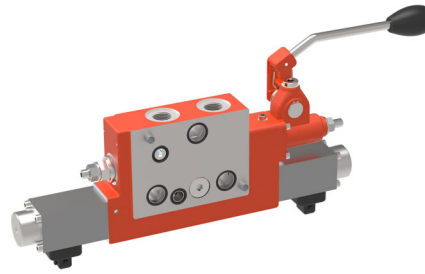

5.3.2 Function

5.3.2.1 LM8S with ON/OFF solenoid, two-stage

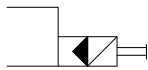

5.3.2.2 LM8S with ON/OFF solenoid, two-stage optional manual override for the valve spool

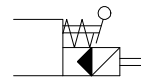

5.3.2.3 LP8S with proportional solenoid, two-stage

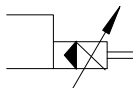

5.3.2.4 LP8S with proportional solenoid, two-stage optional manual override for the valve spool

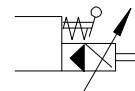

5.3.3 Technical data

General characteristics	Unit	Description, value	
		LM8S	LP8S
Type of operation		ON/OFF	Proportional
Inlet pressure	PSI (bar)	4351 (300)	
Actuator pressure (10 sec/min)	PSI (bar)	max. 4569 (315)	
Spool size	GPM (l/min)	2.64(10) / 4.23(16) / 6.60(25) / 10.57(40) / 16.64(63) / 19.8(75) ¹⁾	
Solenoid design		ON/OFF solenoid with mechanical manual override	Proportional solenoid with mechanical manual override
Nominal voltage	V DC	12 V (10,8 ...14) 24 V (21,6 ...28)	12 or 24
Power consumption	Watt	24	12 or 24
Plug type		DIN 43650, AMP Junior Timer, Deutsch plug DT04-2P-EP04	
Switch frequency	Hz	> 2 (please contact the factory)	
Duty cycle	%	100	100 with I _{max} 1,6 A (U _N 12 V) 0,8 A (U _N 24 V)
Enclosure protection		AMP, GDM: IP65	DT04-2P: IP67 (DIN EN 60529)
Accessories		Joystick brochure 100-P-700051	

¹⁾ 19.81 GPM (75 l/min) only available for spool types 4D and 3J. Higher flow rates on enquiry.

IMPORTANT!

If the maximum nominal voltage is exceeded, the solenoid can be damaged.

5.3.4 Performance graphs

5.3.4.1 Maximum flow rate at directional valve (without compensator), LS function

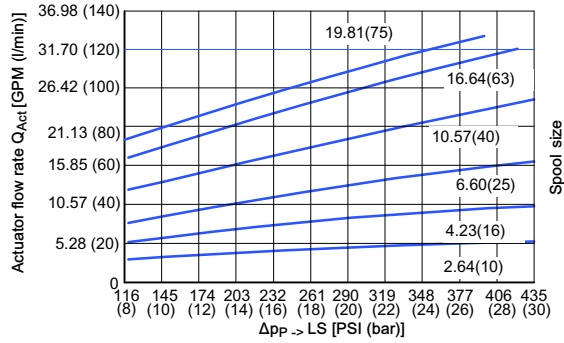

5.3.4.2 Pressure drop A/B -> T (L.8S directional valve)

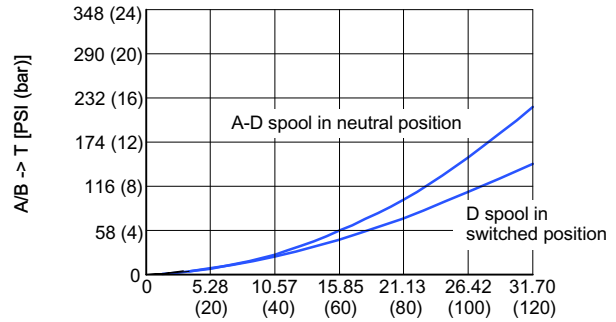

5.3.4.3 Pressure drop P -> A/B (L.8S directional valve), spool at max. switched position

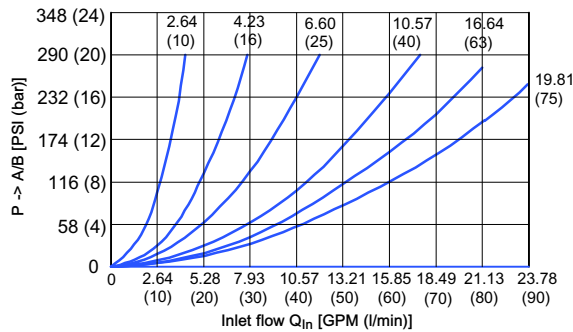

5.3.4.4 Control characteristic (LP8SM..)

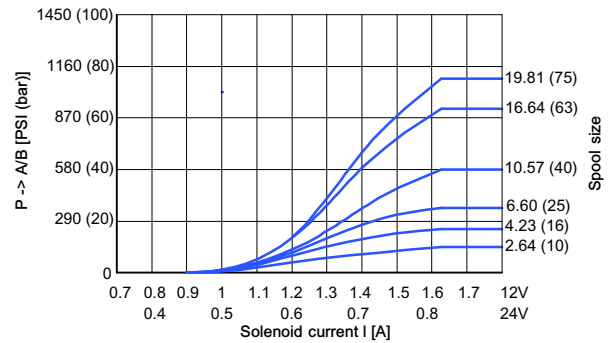

5.3.5 Overview of sections

5.3.5.1 LM8S / LP8S-directional valve with port threads

Symbol	Description	Part number
	L.8SE.....-**-..... • port threads for actuator A and B	see ordering code

5.3.5.2 LM8S / LP8S-directional valve for bolt-on auxiliary valve

Symbol	Description	Part number
	L.8SE.....-M*-..... • for bolt-on auxiliary valves on flange face O	see ordering code
	L.8SM.....-K*..... • for bolt-on auxiliary valves on flange face U	see ordering code
	L.8SM.....-MK-..... • for bolt-on auxiliary valves on flange faces O and U	see ordering code

5.3.6 Option menu for ordering code (ordering code see section 5.3.9)

Spool type (way function, spool function, spool size in GPM (l/min))

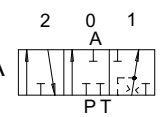
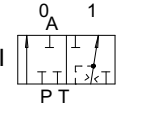
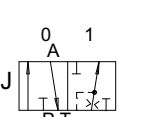
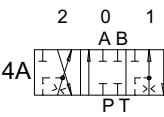
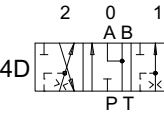
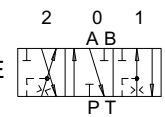
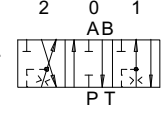
<p>3A</p>  <p>2.64 (10) 4.23 (16) 6.60 (25) 10.57 (40) 16.64 (63)</p> <p>3I</p>  <p>2.64 (10) 4.23 (16) 6.60 (25) 10.57 (40) 16.64 (63) 19.81 (75)</p> <p>3J</p>  <p>2.64 (10) 4.23 (16) 6.60 (25) 10.57 (40) 16.64 (63) 19.81 (75)</p>	<p>4A</p>  <p>1.32 1.32 (05 05) 2.54 2.64 (10 10) 4.23 4.23 (16 16) 6.60 6.60 (25 25) 10.57 10.57 (40 40) 16.64 16.64 (63 63) 19.81 19.81 (75 75)</p> <p>4D</p>  <p>1.32 1.32 (05 05) 2.54 2.64 (10 10) 4.23 4.23 (16 16) 6.60 6.60 (25 25) 10.57 10.57 (40 40) 16.64 16.64 (63 63) 19.81 19.81 (75 75)</p>	<p>4E</p>  <p>2.64 2.64 (10 10) 10.57 10.57 (40 40) 16.64 16.64 (63 63)</p> <p>4F</p>  <p>4.23 4.23 (16 16) 10.57 10.57 (40 40) 16.64 16.64 (63 63)</p>
---	---	---



Control types

ON/OFF solenoid = LM8S
proportional solenoid = LP8S

Operation

Load-independent individual operation = E
load-independent parallel operation = M

Additional operator

without additional operator = *
manual override (with lever) = N
manual override (with rotary knob) (only operative in switch position 1) = S

Attachment to flange face O

port threads for line connection = *
flange face for auxiliary valve = M

Attachment to flange face U

without (valve type E) = *
with (valve type M) = K

Type of connection at face O

flange face to factory standard = ***
line connection to port A and B: ISO 11926: 3/4"-16 UNF 2B = U34

Nominal voltage

12 V DC = 12
24 V DC = 24

Connector socket

GDM plug DIN 43650 = G
AMP Junior Timer = J
Deutsch plug DT04-2P-EP04 = T

5.3.7 Connector socket

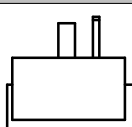
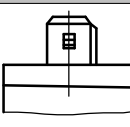
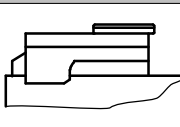
GDM plug to DIN 43650 G	AMP Junior Timer J	Deutsch plug DT04-2P-EP04 T
		

5.3.8 Dimensions [in (mm)]

5.3.8.1 LM8S-/LP8S-Directional valve with port threads

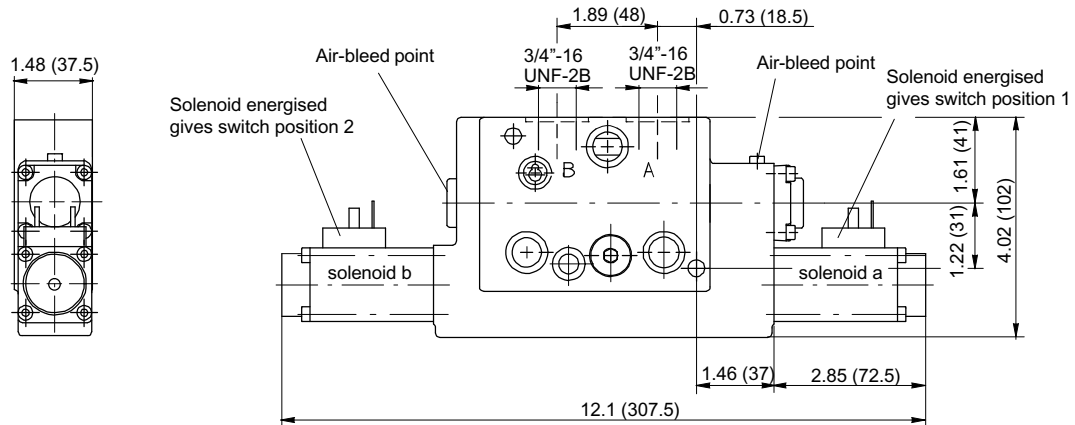

5.3.8.2 LM8S-/LP8S-Directional valve with facility for bolt-on auxiliary valves

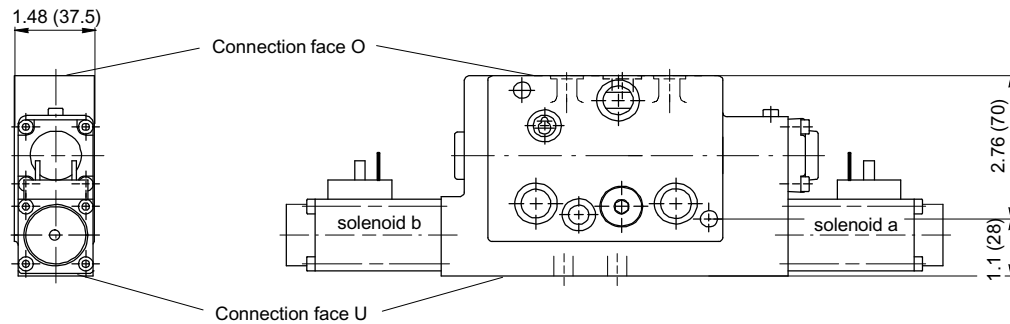

5.3.8.3 LM8S-/LP8S-Directional valve spool types 3I and 3J

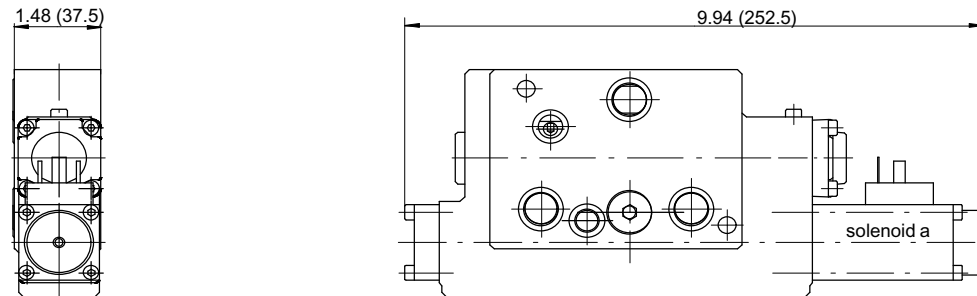

5.3.8.4 Manual override with rotary knob (L.8S.....S..)

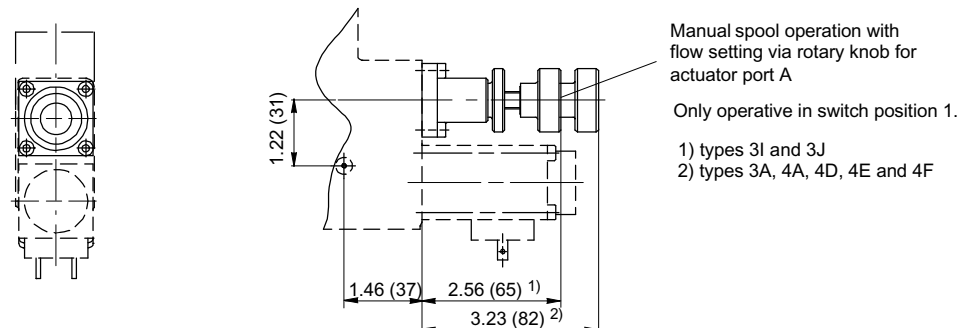

5.3.8.5 Manual override with lever (L.8S.....-N..)

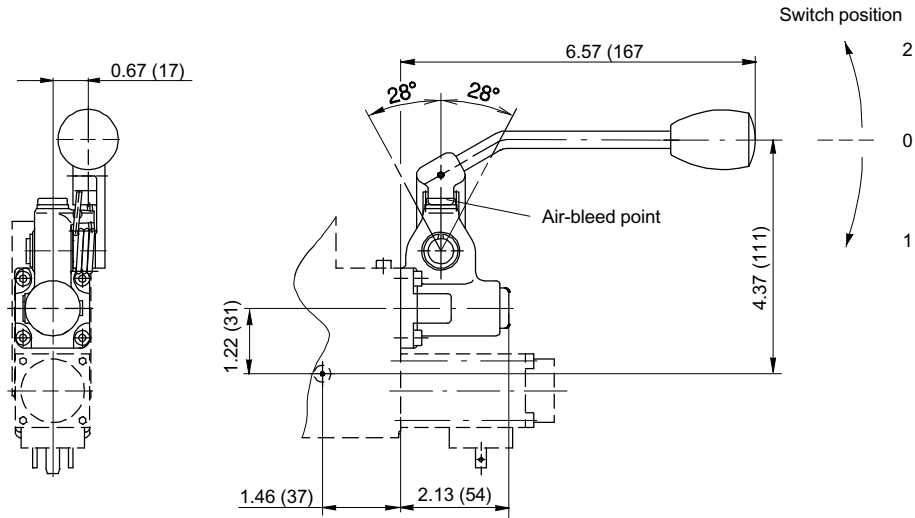

5.3.8.6 Spool stroke limiter (L.8S.../16)

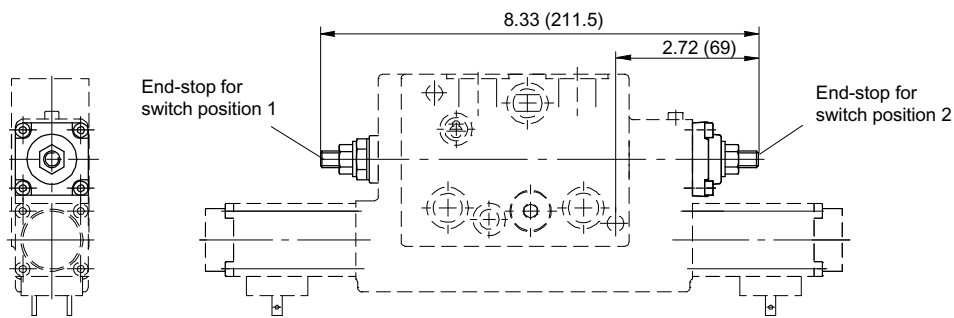

5.3.8.7 Manual override with lever and spool stroke limiter (L.8S.....-N.../16)

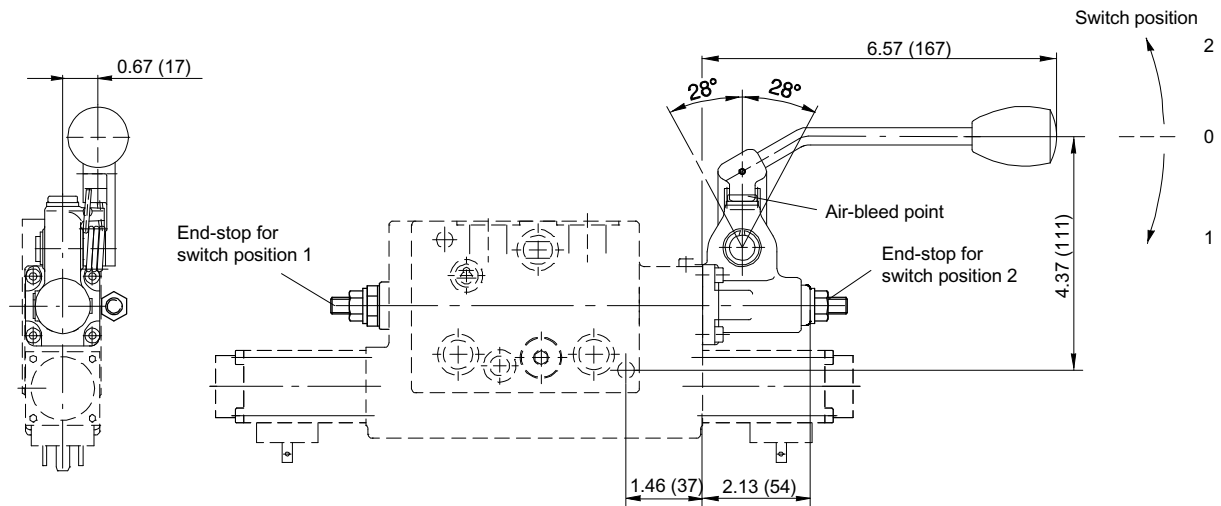

5.3.9 Ordering code

- White fields = data specified by Bucher Hydraulics
- Grey fields = fill out the fields according the option menu 5.3.6

	L	M	8	S	M	4	D	1	0	1	0	-	N	M	K	-	0	*	*	*	J	1	2	/	
ON/OFF solenoid	= LM8S																								
Proportional solenoid	= LP8S																								
Load-independent individual operation	= E																								
Load-independent parallel operation	= M																								
3-way function	= 3																								
4-way function	= 4																								
Spool function	= e.g. D																								
A, D, E, F, I, J																									
Port A spool code	10 (2.64 GPM), 16 (4.23 GPM), 25 (6.6 GPM), 40 (10.57 GPM), 63 (16.64 GPM), 75 ¹⁾ (19.81 GPM)				= e.g. 10																				
Port B spool code	for 3-way valves = **																								
	for 4-way valves:				10 (2.64 GPM), 16 (4.23 GPM), 25 (6.6 GPM), 40 (10.57 GPM), 63 (16.64 GPM), 75 ¹⁾ (19.81 GPM)				= e.g. 10																
Additional operator	without = *																								
	manual override (with lever) = N																								
	manual override (with rotary knob) = S																								
Attachment to connection face O	port thread for line connection = *																								
	flange face for auxiliary valve = M																								
Attachment to connection face U	without (for load-independent individual operation) = *																								
	with (for load-independent parallel operation) = K																								
Design stage	(to be inserted by Bucher Hydraulics)																								
Type of connection at face O	flange face to factory standard = ***																								
	line connection to port A and B: ISO11926: 3/4"-16 UNF-2B = U34																								
Connector socket	GDM plug DIN 43650 = G																								
	Deutsch plug DT04-2P-EP04 = T																								
	AMP Junior Timer = J																								
Nominal voltage	12 VDC = 12																								
	24 VDC = 24																								
Option	spool stroke limiter for A and B = 16																								
	no non-return valve in P (≥ 16,64 GPM (63 l/min)) = 22 ²⁾																								

1) 19.81 GPM (75 l/min) only for spool function 4D and 3J. Higher flow rates on enquiry.

2) P reduced to 3626 psi (250 bar).

5.4 LH8S - Directional valve

5.4.1 Description

These directional valve sections, operated by a hydraulic pilot stage, are distinguished by their slim design and their adaptability.

Auxiliary functions can be bolted on above or below the valve. To enable this, the appropriate interfaces must be chosen (see the following illustrations).

Various manual overrides and end-stops for the spool make it possible to limit the maximum actuator flow to any desired value.

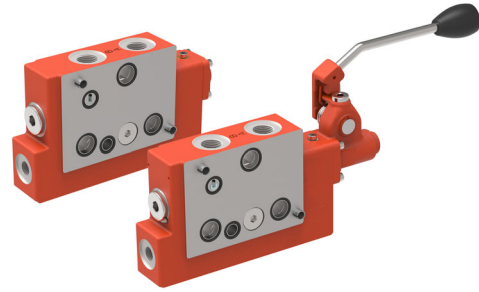

5.4.2 Function

5.4.2.1 LH8S hydraulic operation

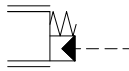

5.4.2.2 LH8S optional manual override for the valve spool

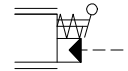

5.4.3 Technical data

General characteristics	Unit	Description, value
Inlet pressure	PSI (bar)	max. 4351 (max. 300)
Actuator pressure (duty cycle 10 sec/min)	PSI (bar)	max. 4569 (max. 315)
Spool size	l/min (GPM)	10 (2.64) / 16 (4.23) / 25 (6.6) / 40(10.57) / 63(16.64) / 75 (19.81) ¹⁾
Pilot pressure	PSI (bar)	max. 725 (max. 50)
Pilot pressure over tank pressure	PSI (bar)	58 ... 232 (4...16) other pilot pressures on request
Accessories		Joystick brochure 100-P-700051

1) 19.81 GPM (75 l/min) only available for 4D and 3J spool types. Higher flow rates on enquiry.

5.4.4 Performance graphs

5.4.4.1 Maximum flow rate at directional valve (without compensator), LS function

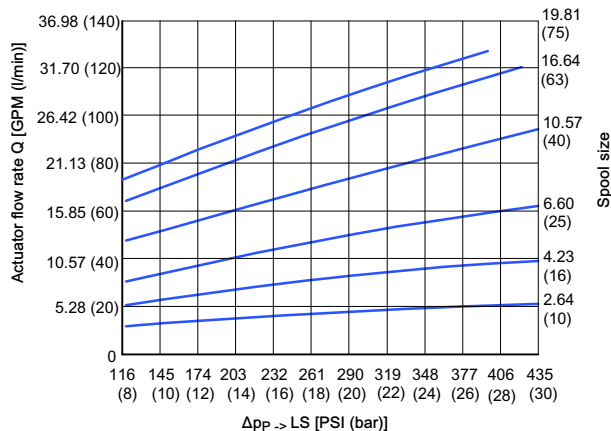

5.4.4.2 Pressure drop A/B -> T (L.8S directional valve)

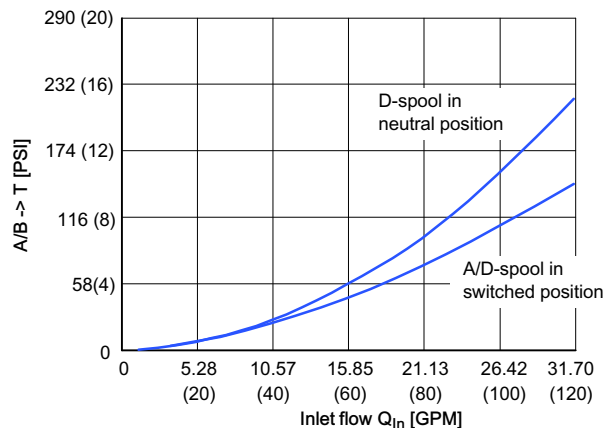

5.4.4.3 Pressure drop P → A/B (L.8S directional valve) spool at max. switched position

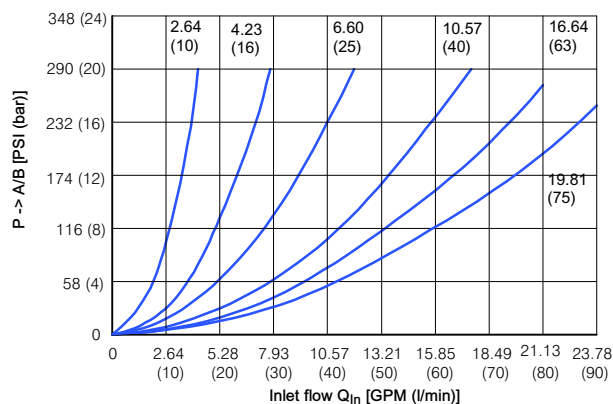

5.4.4.4 Control characteristic

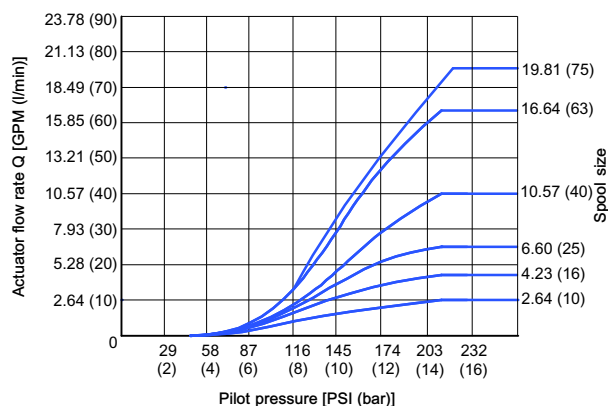

5.4.5 Overview of sections

5.4.5.1 LH8SE-directional valve with port threads

Symbol	Description	Part number
	LH8SE.....-**-..... • port threads for actuator A and B	see ordering code

5.4.5.2 LH8SM-directional valves for bolt-on auxiliary valve

Symbol	Description	Part number
	LH8SM.....-**K-..... • for bolt-on auxiliary valves on flange face U	see ordering code
	LH8SE.....-M*-..... • for bolt-on auxiliary valves on flange face O	see ordering code
	LH8SM.....-MK-..... • for bolt-on auxiliary valves on flange faces O and U	see ordering code

5.4.6 Option menu for ordering code (ordering code see section 5.4.8)

Spool type (way function, spool function, spool size in GPM (l/min))

3A		2.64 (10)	4A		1.32 1.32 (05 05)	4E		2.54 2.64 (10 10)
		4.23 (16)			2.54 2.64 (10 10)			10.57 10.57 (40 40)
		6.60 (25)			6.60 6.60 (25 25)			16.64 16.64 (63 63)
3I		10.57 (40)			10.57 10.57 (40 40)			
		16.64 (63)			16.64 16.64 (63 63)			
3J		2.64 (10)	4D		1.32 1.32 (05 05)	4F		4.23 4.23 (16 16)
		4.23 (16)			4.23 4.23 (16 16)			10.57 10.57 (40 40)
		6.60 (25)			6.60 6.60 (25 25)			16.64 16.64 (63 63)
		10.57 (40)			10.57 10.57 (40 40)			
		16.64 (63)			16.64 16.64 (63 63)			
	19.81 (75)		19.81 19.81 (75 75)					



- Operation**
 - load-independent individual operation = E
 - load-independent parallel operation = M
- Additional operation**
 - without = *
 - manual override (with lever) = N
- Attachment to flange face O**
 - port threads for line connections = *
 - flange face for auxiliary valve = M
- Attachment to flange face U**
 - without (valve type E) = *
 - with (valve type M) = K
- Type of connection at face O**
 - flange face to factory standard = ***
 - line connection to port A and B: ISO11926: 3/4"-16 UNF-2B = U34

5.4.7 Dimensions [in (mm)]

5.4.7.1 LH8S-Directional valve (with port thread for actuator A and B)

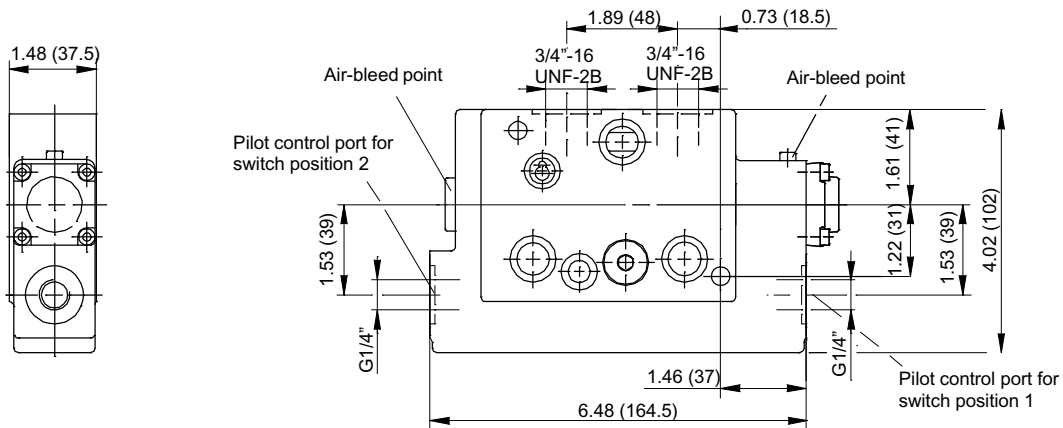

5.4.7.2 LH8S-directional valves (with flange face to bolt-on auxiliary valves)

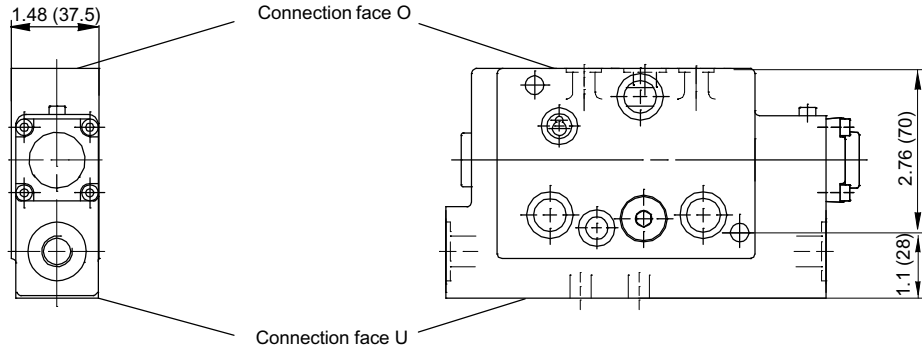

5.4.7.3 Manual override for LH8S-directional valves (LH8S.....-N..)

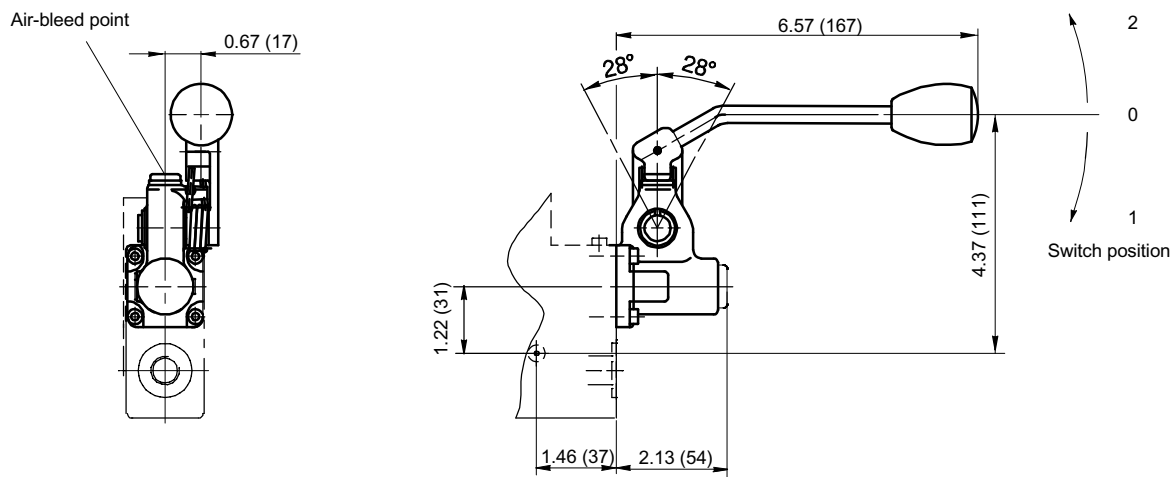

5.4.7.4 Manual override for LH8S-directional valves and spool stroke limiter (LH8S.....-N../16)

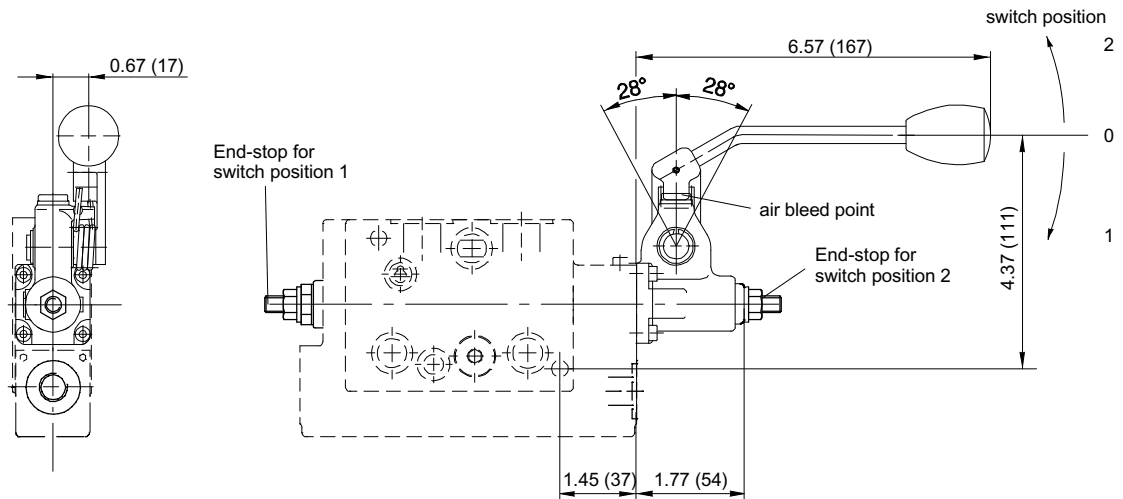

5.4.8 Ordering code

- White fields = data specified by Bucher Hydraulics
- Grey fields = fill out the fields according the option menu 5.4.6

L
H
8
S
M
4
D
2
5
2
5
-
*
*
K
-
1
U
3
4
/

Hydraulic operation = LH8S

Load-independent individual operation = E

Load-independent parallel operation = M

3-way function = 3

4-way function = 4

Spool function

A, D, E, F, I, J = e.g. D

Port A spool code

10 (2.64 GPM), 16 (4.23 GPM), 25 (6.60 GPM),
40 (10.57 GPM), 63 (15.85 GPM), 75 ¹⁾ (19.81) = e.g. 25

Port B spool code

for 3-way function = **
for 4-way function 10 (2.64), 16 (4.23), 25 (6.60)
40 (10.57), 63 (15.85), 75 ¹⁾ (19.81) = e.g. 25

Additional operator

without = *
manual override (with lever) = N

Attachment to connection face O

port threads for line connection = *
flange face for auxiliary valve = M

Attachment to connection face U

without connection face U (for load-independent individual operation) = *
with connection face U (for load-independent parallel operation) = K

Design stage (to be inserted by Bucher Hydraulics)

Type of connection at face O

flange face to factory standard = ***
line connection to ports A and B: ISO11926 3/4"-16 UNF-2B = U34

Option

Spool stroke limiting at A and B = 16
No check valve in P (from 63 l/min) = 22 ²⁾

1) 19.81 GPM (75 l/min) only for spool function 4D and 3J). Higher flow rates on enquiry.

2) P reduces to 3626 psi (250 bar).

6 Auxiliary valves that bolt-on to the top connection face O

6.1 Anti-shock/make-up valve (secondary pressure relief)

6.1.1 Description

These bolt-on anti-shock/make-up valves are mounted on flange face O. They protect the actuator from unacceptably high pressure peaks.

The excess pressure is discharged to tank. The integral make-up function protects against cavitation. The following combinations are available in the pressure ranges listed.

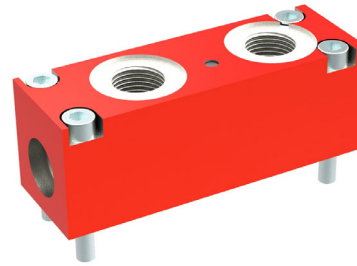





6.1.2 Technical data

General characteristics	Unit	Description, value
Pressure settings available (measured at 2,64 GPM (4 l/min) test flow)	PSI (bar)	1160 (80) / 1450 (100) / 1813 (125) / 2031(140) / 2321 (160) / 2538 (175) / 2756 (190) / 3046 (210) / 3336(230) / 3626 (250) / 4061 (280) / 4351 (300)
Pressure drop through make-up valve	PSI (bar)	58 (4) at 7.93 GPM (30 l/min)
Port threads to ISO 11926		U34 (3/4" -16 UNF-2B)

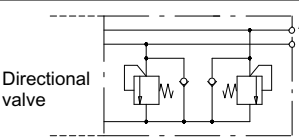
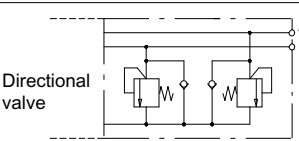
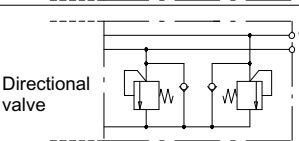
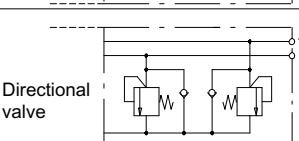
6.1.3 Overview of sections

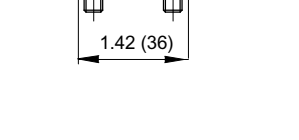
Symbol	Description	Part number
<p>Directional valve</p>	<p>LU8SPET-NVONVO-1U34</p> <ul style="list-style-type: none"> Actuator port A and B: without pressure relief, with make-up valve 	-
<p>Directional valve</p>	<p>LU8SPET-080080-0U34</p> <ul style="list-style-type: none"> Actuator port A and B: with pressure relief p =1160 PSI (80 bar) with make-up valve 	100032019
<p>Directional valve</p>	<p>LU8SPET-100100-0U34</p> <ul style="list-style-type: none"> Actuator port A and B: with pressure relief p =1450 PSI (100 bar) with make-up valve 	100032020
<p>Directional valve</p>	<p>LU8SPET-125125-0U34</p> <ul style="list-style-type: none"> Actuator port A and B: with pressure relief p =1813 PSI (125 bar) with make-up valve 	-
<p>Directional valve</p>	<p>LU8SPET-140140-0U34</p> <ul style="list-style-type: none"> Actuator port A and B: with pressure relief p =2031 PSI (140 bar) with make-up valve 	-
<p>Directional valve</p>	<p>LU8SPET-160160-0U34</p> <ul style="list-style-type: none"> Actuator port A and B: with pressure relief p =2321 PSI (160 bar) with make-up valve 	-

 <p>Directional valve</p>	<p>LU8SPET-175175-0U34</p>	<p>-</p>
	<ul style="list-style-type: none"> • Actuator port A and B: with pressure relief p =2538 PSI (175 bar) with make-up valve 	
 <p>Directional valve</p>	<p>LU8SPET-190190-0U34</p>	<p>-</p>
	<ul style="list-style-type: none"> • Actuator port A and B: with pressure relief p =2756 PSI (190 bar) with make-up valve 	
 <p>Directional valve</p>	<p>LU8SPET-210210-0U34</p>	<p>-</p>
	<ul style="list-style-type: none"> • Actuator port A and B: with pressure relief p =3046 PSI (210 bar) with make-up valve 	
 <p>Directional valve</p>	<p>LU8SPET-230230-0U34</p>	<p>-</p>
	<ul style="list-style-type: none"> • Actuator port A and B: with pressure relief p =3336 PSI (230 bar) with make-up valve 	
 <p>Directional valve</p>	<p>LU8SPET-250250-0U34</p>	<p>-</p>
	<ul style="list-style-type: none"> • Actuator port A and B: with pressure relief p =3626 PSI (250 bar) with make-up valve 	
 <p>Directional valve</p>	<p>LU8SPET-280280-0U34</p>	<p>-</p>
	<ul style="list-style-type: none"> • Actuator port A and B: with pressure relief p =4061 PSI (280 bar) with make-up valve 	
 <p>Directional valve</p>	<p>LU8SPET-300300-0U34</p>	<p>-</p>
	<ul style="list-style-type: none"> • Actuator port A and B: with pressure relief p =4351 PSI (300 bar) with make-up valve 	

Other on request

6.1.4 Dimensions [in (mm)]

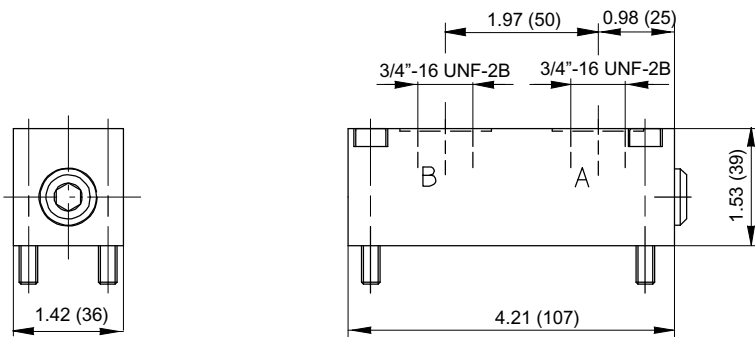

6.2 Check valve (pilot operated non return valve)

6.2.1 Description

These bolt-on check valves with hydraulic or solenoid operation shut off the actuator lines with zero leakage.

The valves must be mounted on connection face O of the directional valve. The following variants are available.

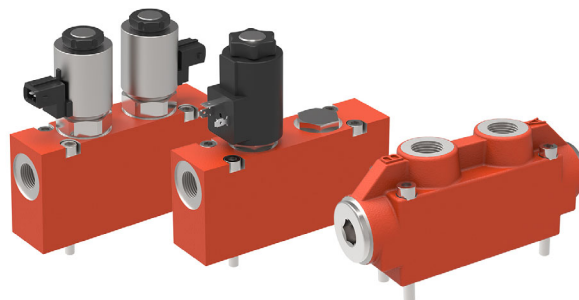

6.2.2 Technical data

General characteristics	Unit	Description, value		
		LU8SPRH...	LU8SPR1-...	LU8SPR2-...
Function		Hydraulic operated	Solenoid operated	Electrohydraulic operated
Nominal flow rate	GPM (l/min)	16.64 (63)	7.93 (30)	18.49 (70)
Operating pressure	PSI (bar)	max. 3626 (250)	max. 3046 (210)	max. 4061 (280)
Actuator pressure	PSI (bar)	max. 4061 (280)	max. 3626 (250)	max. 4351 (300)
Port thread		ISO11926 3/4"-16 UNF-2B		
Ratio of opening pressure to opposing pressure for double-acting cylinders		1 : 6.25 ¹⁾		
Pressure drop	PSI (bar)	102 (7) at 16.64 GPM (63 l/min)	125(10) at 7.93 GPM (30 l/min)	145 (10) at 16.64 GPM(63 l/min)
Nominal voltage	VDC		12 or 24	
Power consumption	Watt		27	22
Duty cycle	%		100	
Enclosure protection			AMP Junior Timer, GDM plug: IP65 Deutsch plug DT04: IP67 (DIN EN 60529)	
Connector socket			GDM plug DIN43650, Deutsch plug DT04-2P-EP04, AMP Junior Timer	

1) Others on request.

6.2.3 Overview of sections

6.2.3.1 LU8SPRH... hydraulic operated, $Q_{max} = 16.64$ GPM (63 l/min)

Symbol	Description	Part number
	LU8SPRH-DVADV-B-0U34 • actuator port A and B: with check valve	100025079
	LU8SPRH-DVA***-0U34 • actuator port A: with check valve • actuator port B: without valve	100025087
	LU8SPRH-***DVB-0U34 • actuator port A: without valve • actuator port B: with check valve	-

Other on request

6.2.3.2 LU8SPR1-... solenoid operation, Q_{max} 7.93 GPM (30 l/min)

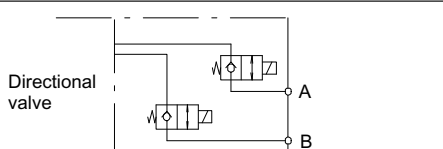
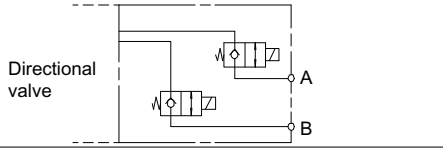
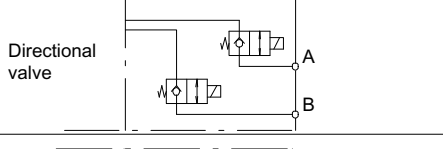
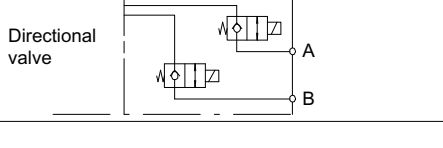
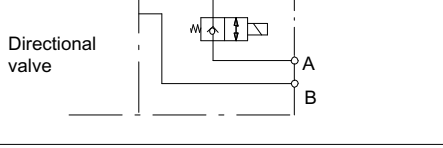
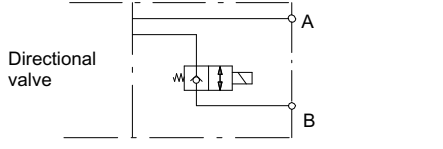
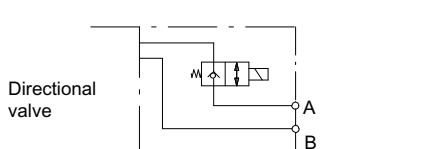
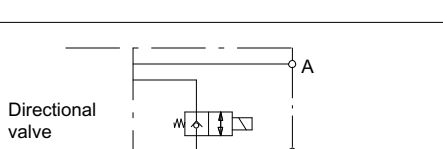
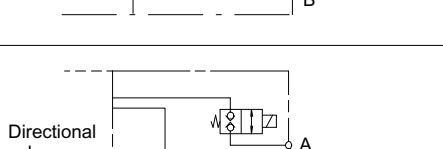
Symbol	Description	Part number
	LU8SPR1-DVADVB-0U34G12 <ul style="list-style-type: none"> actuator port A and B: with check valve connector socket DIN 43650 nominal voltage 12 VDC 	-
	LU8SPR1-DVADVB-0U34G24 <ul style="list-style-type: none"> actuator port A and B: with check valve connector socket DIN 43650 nominal voltage 24 VDC 	-
	LU8SPR1-DVADVB-0U34T12 <ul style="list-style-type: none"> actuator port A and B: with check valve connector socket DT04-2P-EP04 nominal voltage 12 VDC 	-
	LU8SPR1-DVADVB-0U34T24 <ul style="list-style-type: none"> actuator port A and B: with check valve connector socket DT04-2P-EP04 nominal voltage 24 VDC 	-
	LU8SPR1-DVA***-0U34G12 <ul style="list-style-type: none"> actuator port A: with check valve actuator port B: without valve connector socket DIN 43650 nominal voltage 12 V DC 	-
	LU8SPR1-***DVB-0U34G12 <ul style="list-style-type: none"> actuator port A: without valve actuator port B: with check valve connector socket DIN 43650 nominal voltage 12 VDC 	-
	LU8SPR1-DVA***-0U34G24 <ul style="list-style-type: none"> actuator port A: with check valve actuator port B: without valve connector socket DIN 43650 nominal voltage 24 VDC 	-
	LU8SPR1-***DVB-0U34G24 <ul style="list-style-type: none"> actuator port A: without valve actuator port B: with check valve connector socket DIN 43650 nominal voltage 24 VDC 	-
	LU8SPR1-ZVAZVB-0U34G12 <ul style="list-style-type: none"> solenoid operation, Q_{max} 7.93 GPM (30 l/min) actuator port A and B: with dual seat valve connector socket DIN 43650 nominal voltage 12 VDC 	-

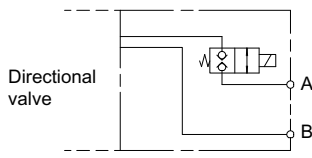
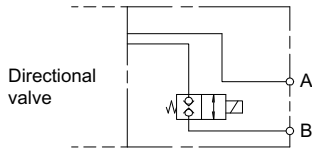
 <p>Directional valve</p>	<p>LU8SPR1-ZVA***-0U34G12</p>	<p>-</p>
 <p>Directional valve</p>	<p>LU8SPR1-***ZVB-0U34G12</p>	<p>-</p>

Other on request

6.2.3.3 LU8SPR2-... solenoid operation, Q_{max} 18.49 GPM (70 l/min)

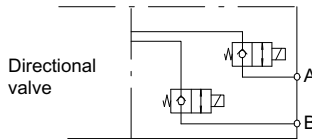
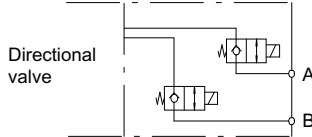
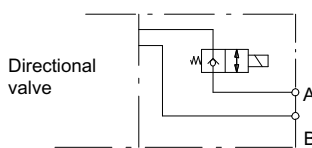
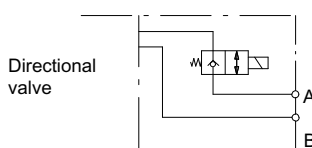
Symbol	Description	Part number
 <p>Directional valve</p>	<p>LU8SPR2-DVADV-1U34G12</p> <ul style="list-style-type: none"> actuator port A and B: with check valve connector socket DIN 43650 nominal voltage 12 VDC 	<p>-</p>
 <p>Directional valve</p>	<p>LU8SPR2-DVADV-1U34G24</p> <ul style="list-style-type: none"> actuator port A and B: with check valve connector socket DIN 43650 nominal voltage 24 VDC 	<p>-</p>
 <p>Directional valve</p>	<p>LU8SPR2-DVA***-1U34G12</p> <ul style="list-style-type: none"> actuator port A: with check valve actuator port B: without valve connector socket DIN 43650 nominal voltage 12 VDC 	<p>-</p>
 <p>Directional valve</p>	<p>LU8SPR2-DVA***-1U34G24</p> <ul style="list-style-type: none"> actuator port A: with check valve actuator port B: without valve connector socket DIN 43650 N' nominal voltage 24 VDC 	<p>-</p>

Others on enquiry.

6.2.4 Connector socket

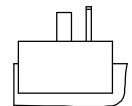
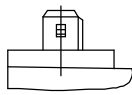
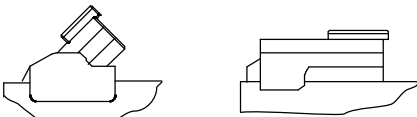
GDM plug to DIN 43650 G	AMP Junior Timer J	Deutsch plug DT04-2P-EP04 T
		

6.2.5 Dimensions [in (mm)]

6.2.5.1 LU8SPRH-...

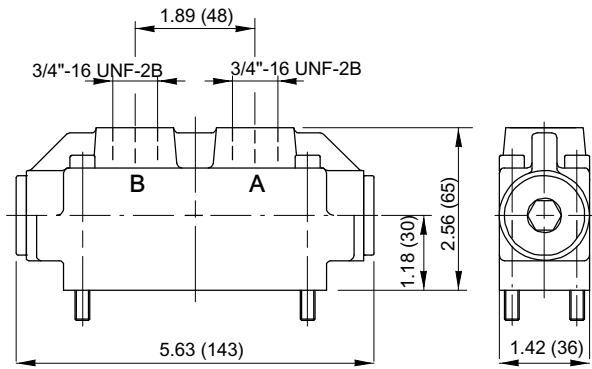

6.2.5.2 LU8SPR1-...

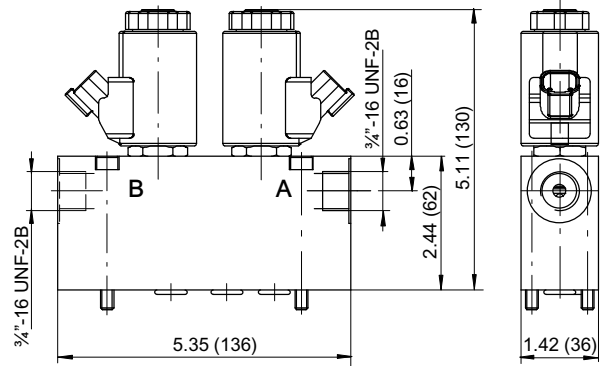

6.2.5.3 LU8SPR2-...

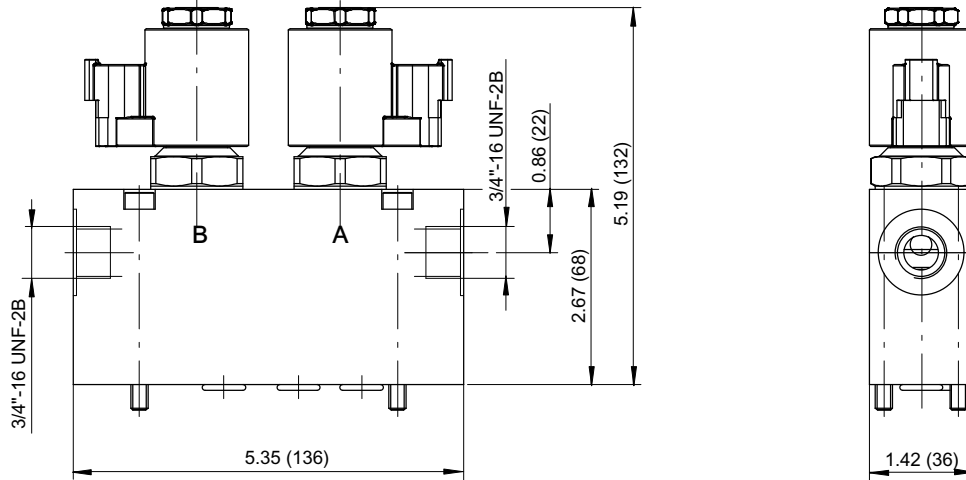

6.3 Load check valve with anti-shock / make-up valve (pilot operated non-return valve with pressure relief on the actuator side)

6.3.1 Description

These bolt-on load check valves with service line anti-shock/make-up valves shut off the actuator lines with zero leakage and protect the actuator from unacceptably-high pressure peaks.

The valves must be mounted on flange face O of the directional valve. The relevant pressure settings are detailed below.

Not usable for LA8S.. valves and LM8S../LP8S.. valves with emergency override.

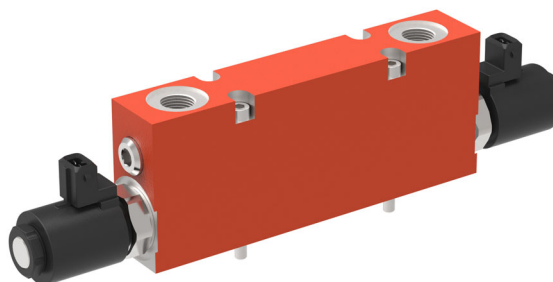

6.3.2 Technical data

General characteristics	Unit	Description, value
Nominal flow rate	GPM (l/min)	18.49 (70)
Operating pressure	PSI (bar)	max. 4061 (280)
Actuator pressure	PSI (bar)	max. 4351 (300)
Pressure drop	PSI (bar)	145 (10) at 16.64 GPM (63 l/min)
Pressure settings available for the pressure relief function, measured at 2.64 GPM (10l/min) test flow	PSI (bar)	1160 (80) / 1450 (100) / 1813 (125) / 2031 (140) / 2321 (160) / 2538 (175) / 2756 (190) / 3046 (210) / 3336 (230) / 3626 (250) / 4061 (280) / 4351 (300)
Port threads		3/4" - 16 UNF-2B
Nominal voltage	VDC	12 or 24
Connector socket		GDM DIN43650, DT04-2P-EP04, AMP Junior Timer
Power consumption	Watt	22
Duty cycle	%	100
Enclosure protection	%	AMP, GDM: IP65 DT04-2P-EP04: IP67 (DIN EN 60529)

6.3.3 Overview of sections

6.3.3.1 LU8SPEC-...

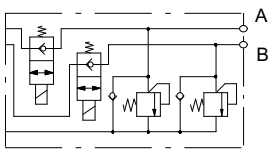
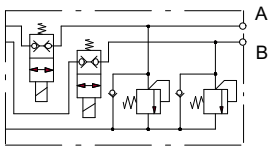
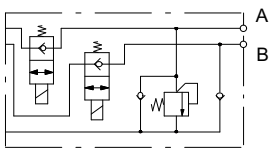
Symbol	Description	Part number
	LU8SPEC-300300-0U34J24 <ul style="list-style-type: none"> actuator port A and B: check valve p = 300 bar flow cut-off connector socket: AMP Junior Timer / nominal voltage 24 V DC 	-
	LU8SPEC-250250-0U34J24/15 <ul style="list-style-type: none"> actuator port A and B: check valve p = 210 bar flow cut-off Qmax = 30 l/min connector socket: AMP Junior Timer / nominal voltage 24 V DC 	-
	LU8SPEC-063NVO-0U34G24 <ul style="list-style-type: none"> actuator port A: check valve p = 063 bar / flow cut-off actuator port B: without check valve connector socket: GDM plug / nominal voltage 24 V DC 	-

	LU8SPEC-080***0U34G24	-
<ul style="list-style-type: none"> • actuator port A: check valve p = 80 bar / flow cut-off • actuator port B: without check valve / flow cut-off • connector socket: GDM plug / nominal voltage 24 V DC 		
	LU8SPEC-100100-0U34G12	-
<ul style="list-style-type: none"> • actuator port A and B: check valve p = 100 bar • flow cut-off • connector socket: GDM plug / nominal voltage 12 V DC 		
	LU8SPEC-175175-0U34G24	-
<ul style="list-style-type: none"> • actuator port A and B: check valve p = 175 bar flow cut-off • connector socket: GDM plug / nominal voltage 24 V DC 		
	LU8SPEC-190190-0U34G24	-
<ul style="list-style-type: none"> • actuator port A and B: check valve p = 190 bar flow cut-off • connector socket: GDM plug / nominal voltage 24 V DC 		
	LU8SPEC-230230-0U34G24	-
<ul style="list-style-type: none"> • actuator port A and B: check valve p = 230 bar • flow cut-off • connector socket: GDM plug / nominal voltage 12 V DC 		
	LU8SPEC-280280-0U34J24/15	-
<ul style="list-style-type: none"> • actuator port A and B: check valve p = 210 bar flow cut-off • Q_{max} = 30 l/min • connector socket: AMP Junior Timer / nominal voltage 24 V DC 		
	LU8SPEC-250250-0U34J12/15	-
<ul style="list-style-type: none"> • actuator port A and B: check valve p = 210 bar flow cut-off • Q_{max} = 30 l/min • connector socket: AMP Junior Timer / nominal voltage 12 V DC 		

Others on enquiry.

6.3.4 Connector socket

GDM plug to DIN 43650 G	AMP Junior Timer J	DT04-2P-EP04 T

6.3.5 Dimensions [in (mm)]

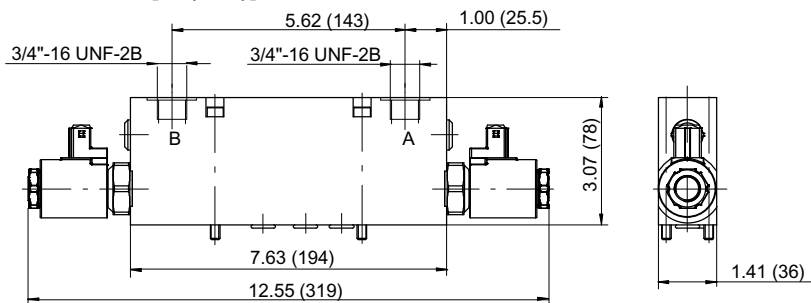

6.4 Load control valve

6.4.1 Description

These bolt-on load control valves with integral anti-shock function ensure load-independent lowering motion at speeds determined by the inlet flow. The load-control valves close without leakage when the directional valve is in its neutral position. The anti-shock valve setting should preferably be 120% of the highest load pressure. Turning the adjusting screw in the clockwise direction reduces the setting, and this can also be used for emergency lowering of the load.

The valves must be mounted on flange face O.
The following variants are available.

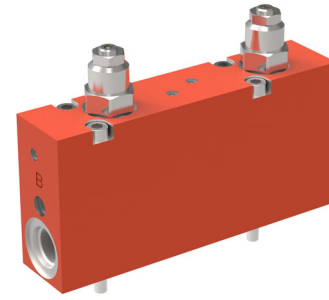

6.4.2 Function

6.4.2.1 LU8SPBH-***S...-...

Load-holding valve at port B, orifice damping facility in the control line. Directional valve spool type 4F preferred.

6.4.2.2 LU8SPBH-S...S...-...

Load-holding valves at port A and B. Directional valve spool type 4D preferred.

6.4.3 Technical data

General characteristics	Unit	Description, value
Port threads to ISO 11926		3/4"-16 UNF-2B
Pressure drop	PSI (bar)	363 (25) at 16.64 GPM (63 l/min)
Anti-shock valve adjustable	PSI (bar)	1015 ... 4061 (70 ... 280)
Standard pilot ratios		1,5:1 / 2,3:1 / 3:1 1)

1) For other pilot ratios, please enquire.

6.4.4 Overview of sections

Symbol	Description	Part number
	LU8SPBH-S15S15-0U34 P= <ul style="list-style-type: none"> Actuator port A and B: with load control, pilot ratio 1,5:1 ⇒ Specify the pressure relief setting in bar	-
	LU8SPBH-***S15-0U34 P= <ul style="list-style-type: none"> Actuator port A: without load-control Actuator port B: with load-control, pilot-ratio 1,5 : 1 ⇒ Specify the pressure relief setting in bar	-
	LU8SPBH-S30S30-0U34 P= <ul style="list-style-type: none"> Actuator port A and B: with load-control, pilot-ratio 3:1 ⇒ Specify the pressure relief setting in bar	-
	LU8SPBH-***S30-0U34 P= <ul style="list-style-type: none"> Actuator port A: without load-control Actuator port B: with load-control, pilot-ratio 3:1 ⇒ Specify the pressure relief setting in bar	-

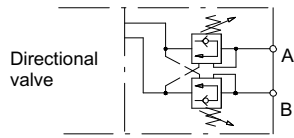
 <p>Directional valve</p>	<p>LU8SPBH-S23S23-0U34 P=</p> <ul style="list-style-type: none"> • Actuator port A and B: with load-control, pilot-ratio 2,3:1 <p>⇒ Specify the pressure relief setting in bar</p>	<p>-</p>
--	--	----------

6.4.5 Dimensions [in (mm)]

6.4.5.1 LU8SSPBH-***S../LU8SSPBH-...S..

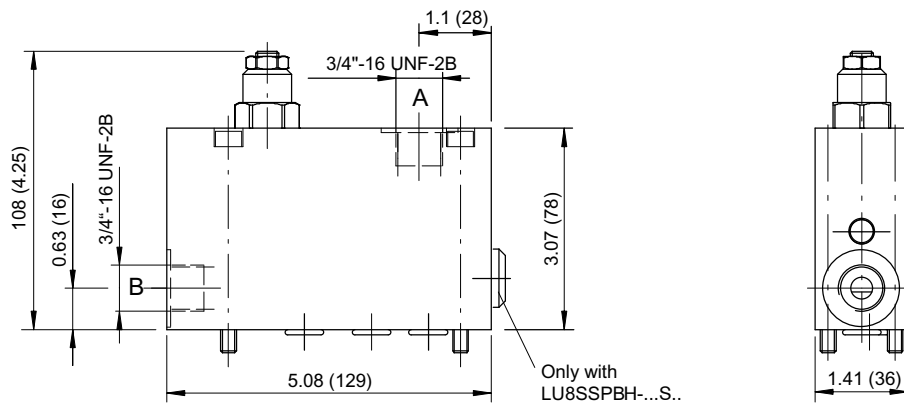

6.4.5.2 LU8SSPBH-S..S..

Cannot be combined with manual override on LM8S/LP8S;
LA8S only when the lever pointing down.

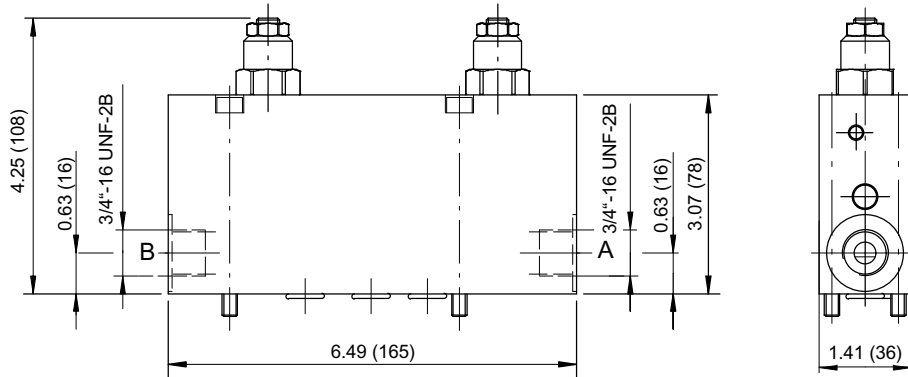

7 Auxiliary valves that bolt-on to the bottom connection face U

7.1 Individual pressure compensator without/with flow cut-off (torque-limiting)

7.1.1 Description

The individual pressure compensators (2-way compensators), which bolt-on to the bottom of the directional valve, keep the Δp over the spool opening at a constant level, even with high inlet pressures. This means that the actuator flow remains constant and load-independent even if another actuator that needs a higher pressure is operated at the same time. There is an optional flow cut-off function at an adjustable pressure, above which level the actuator flow goes to zero. The valves must be mounted on flange face U of the directional valve.

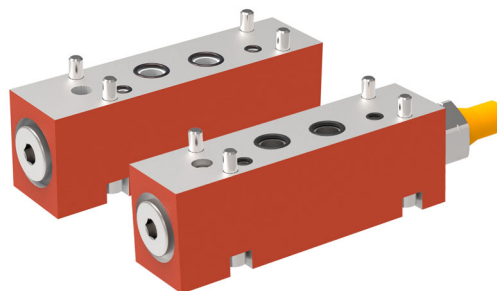

7.1.2 Technical data

General characteristics	Unit	Description, value
Operating pressure	PSI (bar)	max. 4351 (300)
Pressure for flow cut-off	PSI (bar)	adjustable, 725 ... 4351 (50 ... 300)
Nominal flow rate SKL / SKM SKJ / SKH	GPM (l/min)	max. 16.64 (63) max. 19.81 (75)

7.1.3 Performance graphs

7.1.3.1 Maximum flow rate at directional valve when using the LU8SSKL/SKM compensator in conjunction with an LU8SSCS inlet section

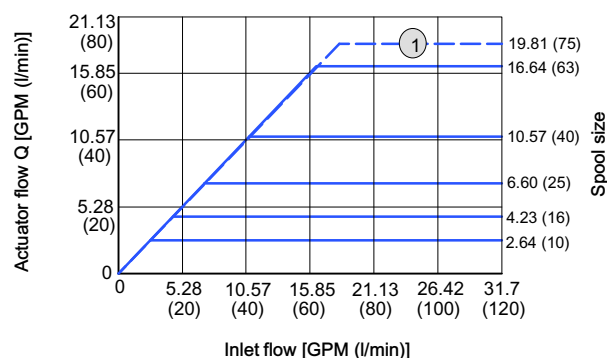

7.1.3.2 Flow cut-off function in conjunction with an LU8SSKM/SKJ bottom-mounting plate

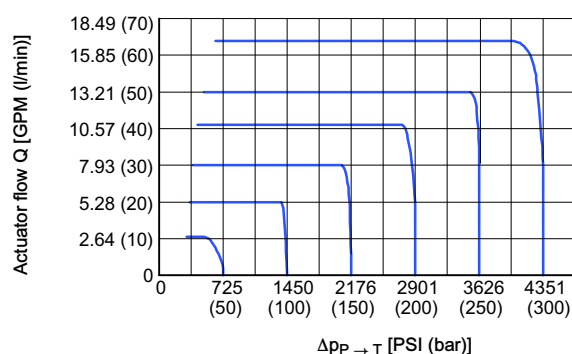

1 Maximum flow rate at directional valve when using the LU8SSKH / SKJ compensator in conjunction with an LU8SSCS inlet section

7.1.4 Overview of sections

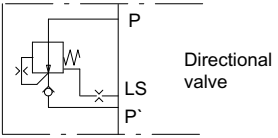
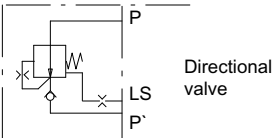
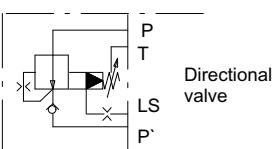
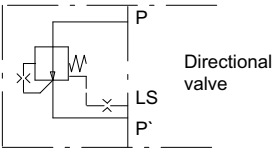
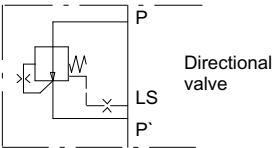
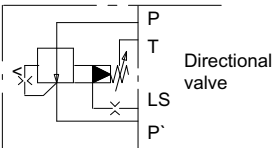
Symbol	Description	Part number
	LU8SSKL-0 <ul style="list-style-type: none"> • without flow cut-off • with no-drop function • nominal flow rate maximum 16.64 GPM (63 l/min) 	100015779
	LU8SSKL-0/01 <ul style="list-style-type: none"> • without flow cut-off • with no-drop function • damped model • nominal flow rate maximum 16.64 GPM (63 l/min) 	100013943
	LU8SSKM-0 P= <ul style="list-style-type: none"> • with flow cut-off • with no-drop function • nominal flow rate maximum 16.64 GPM (63 l/min) ⇒ specify the pressure relief setting in bar, (50 ... 300 bar)	100015865
	LU8SSKH-0 <ul style="list-style-type: none"> • without flow cut-off • without no-drop function • nominal flow rate maximum 23.78 GPM (90 l/min) 	100025901
	LU8SSKH-0/01 <ul style="list-style-type: none"> • without flow cut-off • without no-drop function • damped model • nominal flow rate maximum 23.78 GPM (90 l/min) 	100027017
	LU8SSKJ-0 P= <ul style="list-style-type: none"> • with flow cut-off • without no-drop function • nominal flow rate maximum 23.78 GPM (90 l/min) ⇒ specify the pressure relief setting in bar	100024646

7.1.5 Dimensions [in (mm)]

7.1.5.1 LU8SSKL / LU8SSKM

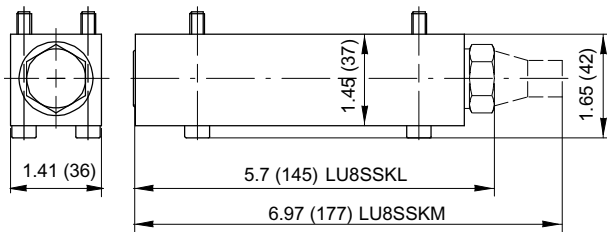

7.1.5.2 LU8SSKH / LU8SSKJ

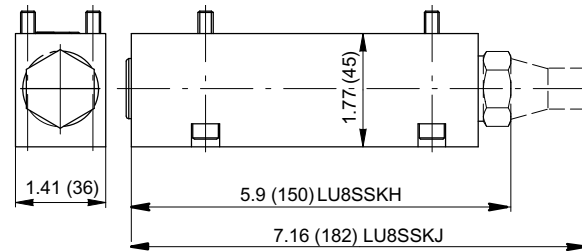

7.2 Flow limiter without/with individual pressure compensators

7.2.1 Description

This flow limiters, which bolt-on to the bottom of the directional valve, are another metering orifice in addition to the one in the spool in the directional valve. This means that the usual flow rate, which is determined by the size of the spool, can be reduced or limited to any desired level by means of a small hand wheel.

Optionally, this function can be combined with an individual pressure compensator for independent parallel operation, and also with a flow cut-off function. The valves must be mounted on connection face U of the directional valve.

This section can not be combined with the manual override design on the LP8S/LM8S valves.

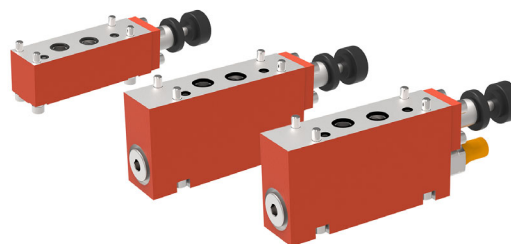

7.2.2 Technical data

General characteristics	Unit	Description, value
Operating pressure	PSI (bar)	max. 4351 (300)
Pressure for flow cut-off	PSI (bar)	adjustable, 725 ... 4351 (50 ... 300)
Nominal flow rate	GPM (l/min)	max. 16.64 (63)

7.2.3 Performance graphs

7.2.3.1 Flow rate calibration - LU8SSDR

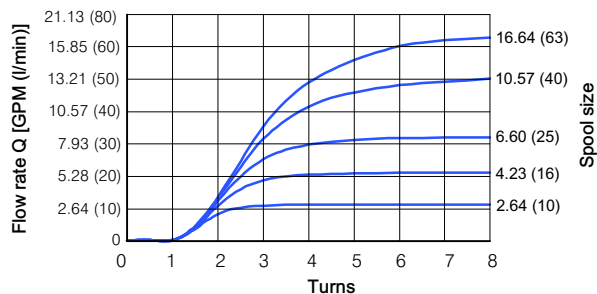

7.2.3.2 Flow rate calibration LU8SSKR

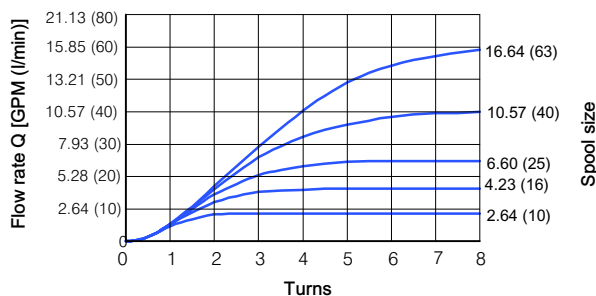

7.2.3.3 Flow cut-off function in conjunction with an LU8SSKS bottom-mounting section

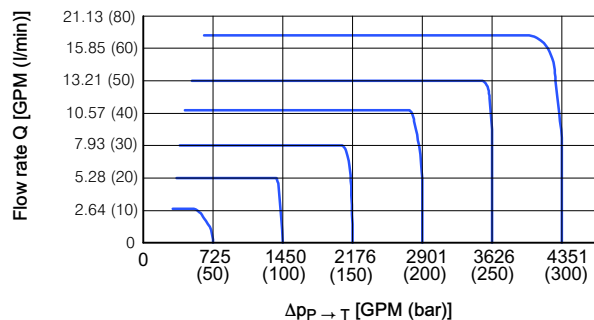

7.2.4 Overview of sections

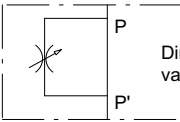
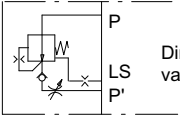
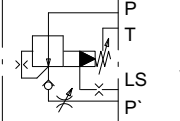
Symbol	Description	Part number
 <p>Directional valve</p>	<p>LU8SSDR-0LU-Q</p> <ul style="list-style-type: none"> • with flow limiter 	<p>100017758</p>
 <p>Directional valve</p>	<p>LU8SSKR-0</p> <ul style="list-style-type: none"> • with flow limiter • with 2-way compensator 	<p>100017752</p>
 <p>Directional valve</p>	<p>LU8SSKS-0</p> <ul style="list-style-type: none"> • with flow limiter • with 2-way compensator • with flow cut-off 	<p>100027948</p>

7.2.5 Dimensions

7.2.5.1 LU8SSDR

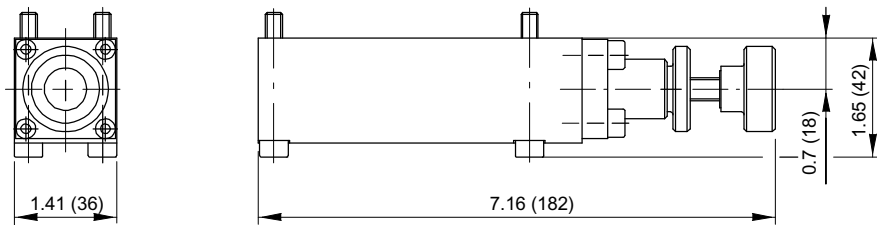

7.2.5.2 LU8SSKR / SKS

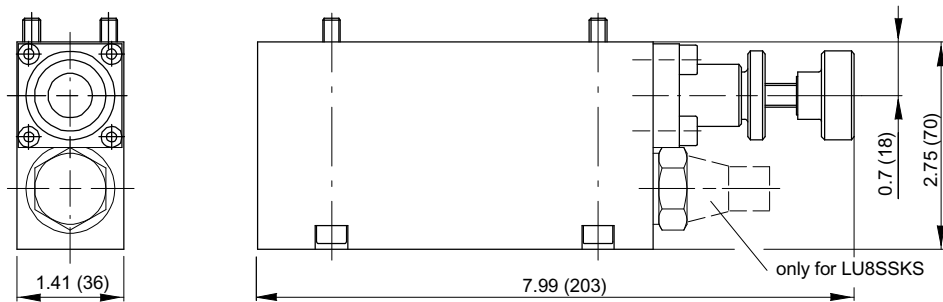

7.3 Pressure reducing compensator

7.3.1 Description

These pressure reducing compensators, which bolt-on to the bottom of the directional valve, can be switched between the individual compensator and 3-way pressure reducing functions. By energising solenoid Y, the valve is switched into individual-compensator mode. In pressure-reducing mode, preselection of the appropriate actuator line allows a preset pressure to act at port A or B. The pressure setting can be altered by hand or by electro-proportional solenoid (solenoid X).

The valves must be mounted on flange face U of the directional valve.

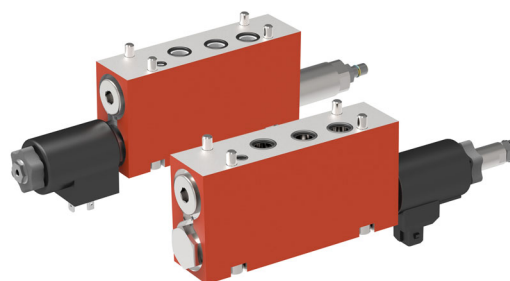

7.3.2 Technical data

General characteristics		Unit	Description, value	
			Pressure range 1-4 electro-proportional	Pressure range 6-8 manual setting
Pressure range	1 2 3 4 6 7 8	PSI (bar)	914 (63) 1450 (100) 2321 (160) 3336 (230)	1450 (100) 2321 (160) 3626 (250)
Operating pressure		PSI (bar)	max. 3626 (250)	
Minimum pressure always		PSI (bar)	218 (15) above tank pressure	
Nominal flow rate		GPM (l/min)	max. 6.6 (25)	
Solenoid voltage		VDC	12 or 24	
Connector socket			DIN 43650, DT04-2P-EP04, AMP Junior Timer	
Power consumption	solenoid X solenoid Y	Watt	max. 19	27
Duty cycle	solenoid X solenoid Y	%	100 at I_{max} 1.4 A (U_N 12 V) / 0.7 A (U_N 24 V) 100	
Enclosure protection			AMP, GDM: IP65	DT: IP67 (DIN EN 60529)

7.3.3 Performance graphs

7.3.3.1 Pressure control characteristic with proportional control of solenoid X

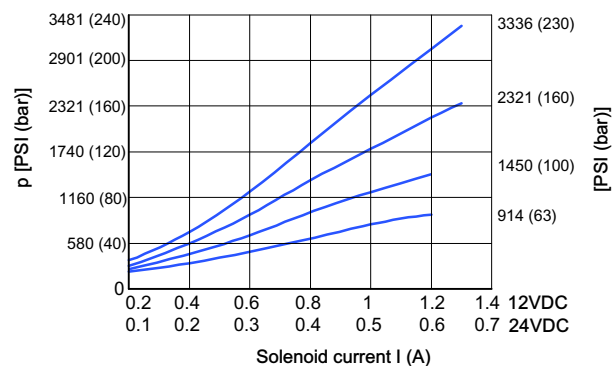

7.3.3.2 Typical pressure profile 3-way pressure control, Electroproportional

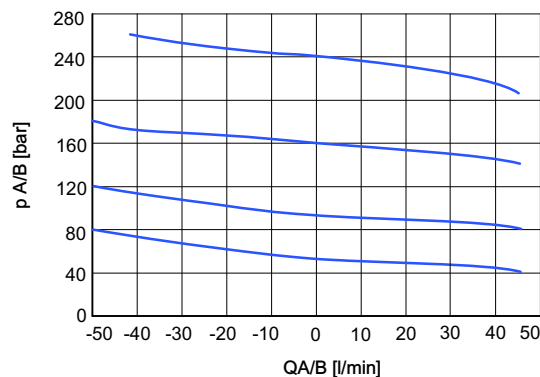

7.3.4 Overview of sections

7.3.4.1 LU8SSDK-... - Pressure reducing compensator switchable to 2-way compensator

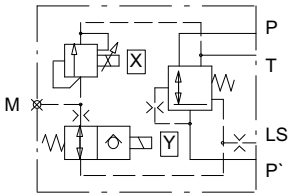
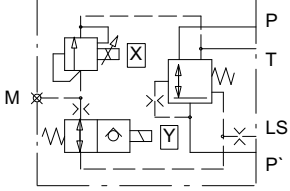
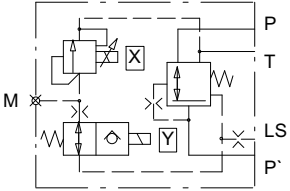
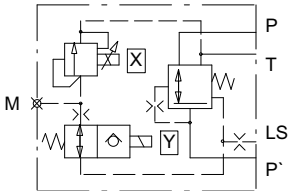
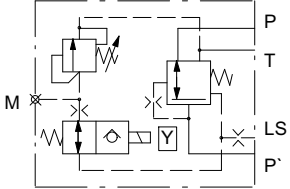
Symbol	Description	Part number
	LU8SSDK2-1J12	100039398
	<ul style="list-style-type: none"> • switchable to 2-way compensator • pressure setting : electro-proportional p= 100 bar • connector socket: AMP Junior Timer • nominal voltage 12 V DC 	
	LU8SSDK2-2G12	100040605
	<ul style="list-style-type: none"> • switchable to 2-way compensator • pressure setting : electro-proportional p= 100 bar • connector socket: GDM plug DIN 43650 • nominal voltage 12 V DC 	
	LU8SSDK3-1G24	100022559
	<ul style="list-style-type: none"> • switchable to 2-way compensator • pressure setting : electro-proportional p= 160 bar • connector socket: GDM plug DIN 43650 • nominal voltage 24 V DC 	
	LU8SSDK4-1G12	100029617
	<ul style="list-style-type: none"> • switchable to 2-way compensator • pressure setting : electro-proportional p= 250 bar • connector socket: GDM plug DIN 43650 • nominal voltage 12 V DC 	
	LU8SSDK6-1G124	100023229
	<ul style="list-style-type: none"> • switchable to 2-way compensator • pressure setting : manual p= 100 bar • connector socket: GDM plug DIN 43650 • nominal voltage 24 V DC 	

7.3.4.2 LU8SSDO-... - Pressure reducing compensator not switchable

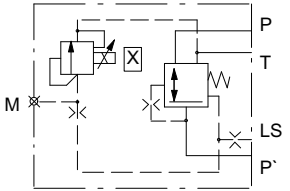
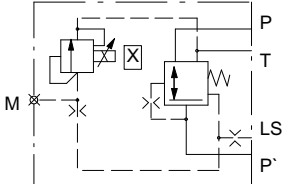
Symbol	Description	Part number
	LU8SSDO1-1T24	100034455
	<ul style="list-style-type: none"> • not switchable to 2-way compensator • pressure setting : electro-proportional p= 63 bar • connector socket: DT04-2P-EP04 • nominal voltage 24 V DC 	
	LU8SSDO2-2G12	100040606
	<ul style="list-style-type: none"> • not switchable to 2-way compensator • pressure setting : electro-proportional p= 100 bar • connector socket: GDM plug DIN 43650 • nominal voltage 12 V DC 	

	<p>LU8SSDO3-1G24</p> <p>100028923</p> <ul style="list-style-type: none"> • not switchable to 2-way compensator • pressure setting : electro-proportional p= 160 bar • connector socket: GDM plug DIN 43650 • nominal voltage 24 V DC 	
	<p>LU8SSDO4-1J12</p> <p>100036098</p> <ul style="list-style-type: none"> • switchable to 2-way compensator • pressure setting : electro-proportional p= 230 bar • connector socket: AMP Junior Timer • nominal voltage 12 V DC 	
	<p>LU8SSDO4-1T12</p> <p>100035166</p> <ul style="list-style-type: none"> • not switchable to 2-way compensator • pressure setting : electro-proportional p= 230 bar • connector socket: Deutsch plug DT04-2P-EP04 • nominal voltage 12 V DC 	

Others on enquiry.

7.3.5 Connector socket

GDM plug to DIN 43650 G	AMP Junior Timer J	Deutsch plug DT04-2P-EP04 T

7.3.6 Dimensions [in (mm)]

7.3.6.1 Pressure range 1 - 4

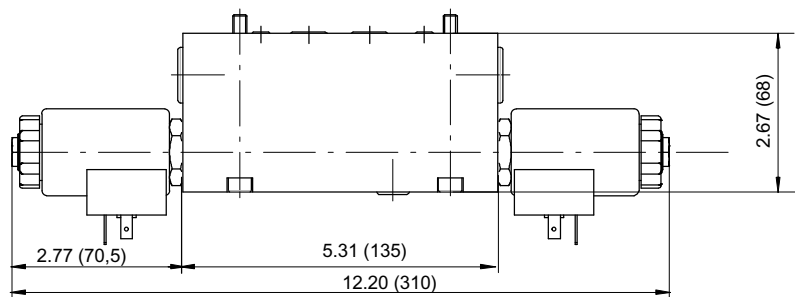

7.3.6.2 Pressure range 6 - 8

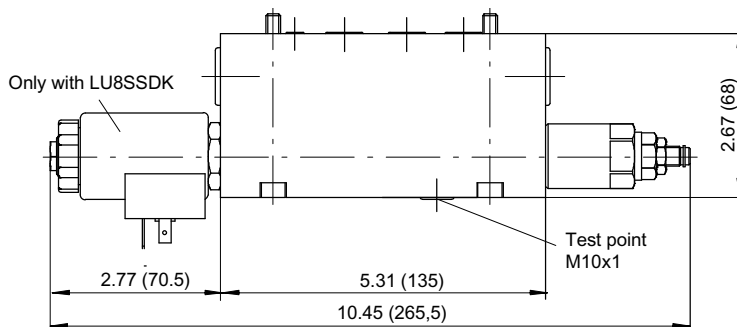

8 End sections

8.1 With no control function

8.1.1 Description

End sections with no control function are intended for the end of a valve block when no other control functions are needed. The LS signal is unloaded to tank. The ports needed for the particular model are provided, as are tapped holes for securing the valve block.

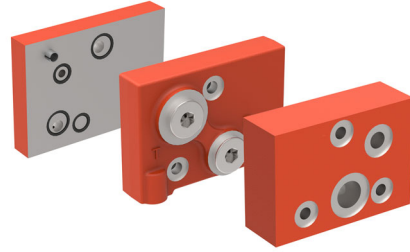

8.1.2 Overview of sections

Symbol	Description	Part number
	LU8SPUB-0 • end section without ports • LS to T	100020665
	LU8SPUT-1U78 • tank port T and pressure port P = 7/8"-14 UNF-2B • LS to T	100025078
	LU8SPWS-0U78 • pressure port P = 7/8"-14 UNF-2B • LS port = 9/16"-18 UNF-2B • LS carry-over (if unloading, remember the LS signal)	100029852

8.1.3 Dimensions [in (mm)]

8.1.3.1 LU8SPUB

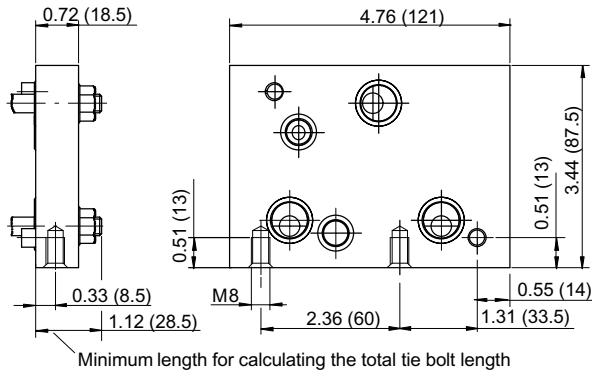

8.1.3.2 LU8SPUT

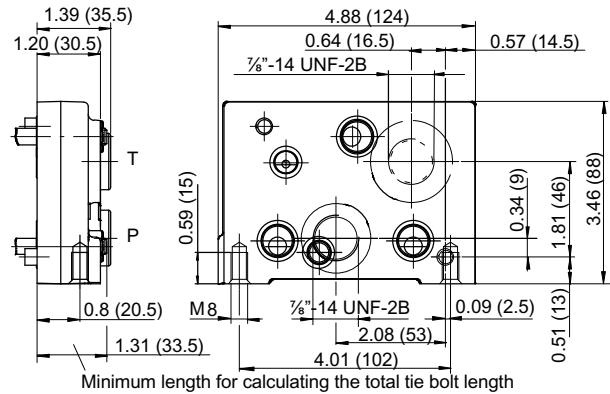

8.1.3.3 LU8SPWS

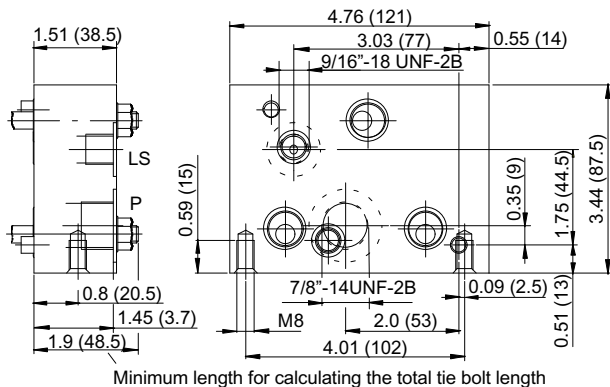

8.2 Priority section

8.2.1 Description

Intended for the end of a valve block, the LU8SPUO/PUP... priority section includes a priority function for the external control system supplied by the ports P_P and LS, and the surplus flow side.

In the under-supply range (pump flow < total flow needed by the valve block), the surplus flow side will receive only a portion of what it needs, or possibly (pump flow < priority flow setting) no flow whatsoever.

The priority side can also be equipped with a pressure relief valve that ensures a priority flow cut-off when the pressure setting is reached. For oscillation-prone applications, a damping element (e.g. An accumulator) can be connected to a port specially provided for this purpose. Preferred applications are in LS systems.

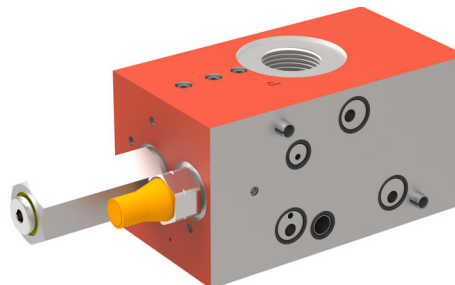

8.2.2 Technical data

General characteristics	Unit	Description, value
Inlet pressure	PSI (bar)	max. 4351 (300)
Nominal flow rate	GPM (l/min)	max. 31.7 (120)
Control Δp for the compensator	PSI (bar)	174 (12)
Pressure for flow cut-off on the priority side	PSI (bar)	adjustable

8.2.3 Performance graphs

8.2.3.1 Pressure drop characteristic

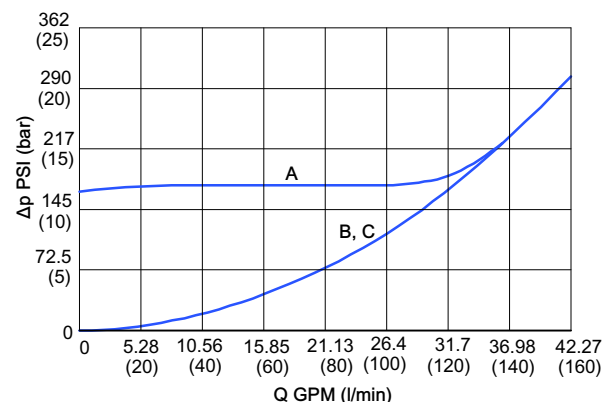

A	P _{Pump port} to P _{Surp} (Q _{Priority} = zero) at P _{Surp} = P _{LS}
B	P _{Pump port} to P _{Surp} at Δp P _{Surp} to LS > 20 bar
C	P _{Pump port} to P _{priority} (control spool in neutral position)

8.2.3.2 Flow cut-off on the priority side

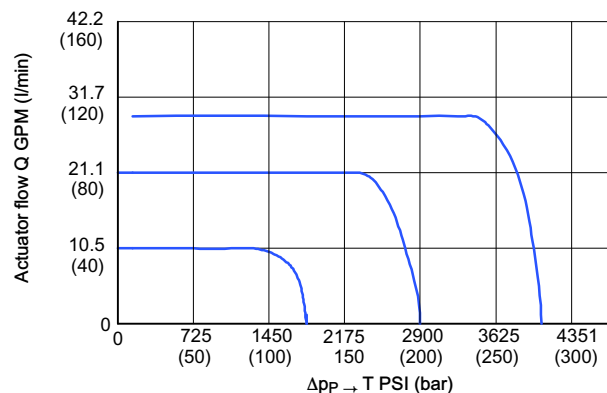

8.2.4 Overview of sections

Symbol	Description	Part number
	<p>LU8SPUP-0U78/01 P=</p> <ul style="list-style-type: none"> • flow cut-up • port threads $\frac{7}{8}$" -14 UNF-2B 	100033370

8.2.5 Dimensions

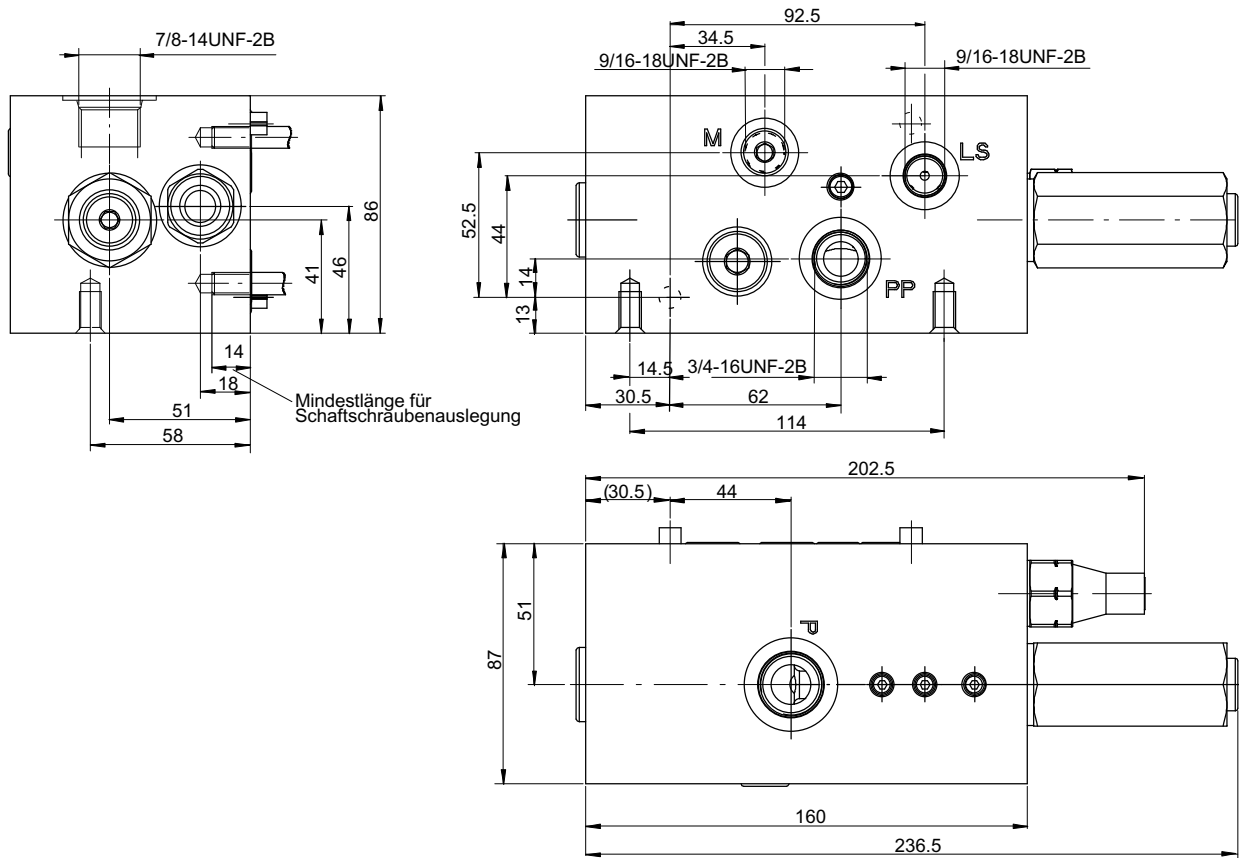

8.3 With direct-acting pressure relief

8.3.1 Description

For terminating the block with integral direct-acting pressure relief (e.g. secondary pressure relief in LS systems). The application limits must not be exceeded. A test point for P, and tapped holes for securing the valve block are provided.

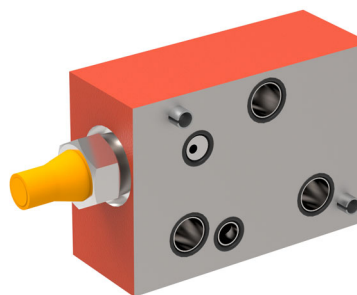

8.3.2 Technical data

General characteristics	Unit	Description, value
Inlet pressure	PSI (bar)	max. 4351 (300)
Nominal flow rate	GPM (l/min)	see characteristic curve
Pressure range	PSI (bar)	507 ... 1377 (35 - 95)
		1377 ... 3045 (95 - 210)
		3045 ... 4351 (210 - 300)

8.3.3 Characteristic curve

8.3.3.1 Pressure relief characteristic

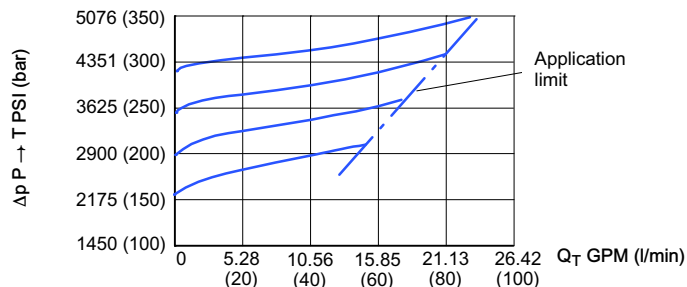

8.3.4 Overview of sections

Symbol	Description	Part number
	LU8SPUD3-0M14 P= <ul style="list-style-type: none"> • end section • pressure range 3045 ... 4351PSI (210 ... 300 bar) (others on enquiry) • port thread to 9/16"-18 UNF-2B ⇒ specify the pressure relief setting in bar	-

8.3.5 Dimensions [in (mm)]

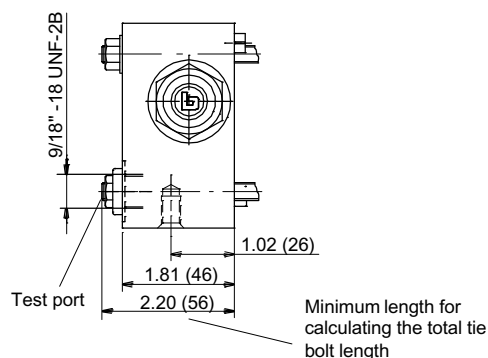
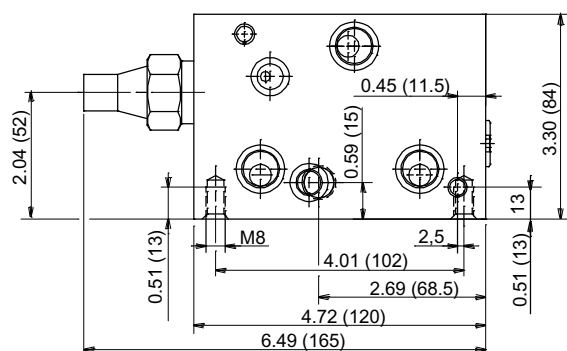

8.4 With pressure reducing function e.g. for hydraulic joystick

8.4.1 Description

This end section includes a pressure reducing valve and the ports PX and TX. The reduced pressure available at port PX can be varied by the adjusting screw to any required level from 145 ... 1450 PSI (10 ... 100 bar). A typical application is providing the supply for hydraulic joysticks. No tank unload facility at the upper tie bolt gallery. The upper tank gallery is not connected to the tank port.



8.4.2 Technical data

General characteristics	Unit	Description, value
Operating pressure	PSI (bar)	max. 3626 (250)
Flow rate at port PX	GPM (l/min)	max. 3,96 (15)
Reduced pressure at PX preset	PSI (bar)	725 (50)
Reduced pressure at PX adjustable	PSI (bar)	max. 1450 (100)

8.4.3 Overview of sections

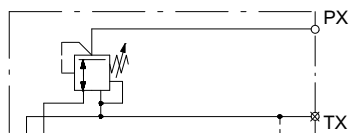
Symbol	Description	Part number
	LU8SPUH-0U91 P= 50 (725 PSI) <ul style="list-style-type: none"> end section port threads to ISO 11926: 9/16"-18 UNF-2B 	100031471

8.4.4 Dimensions [in (mm)]

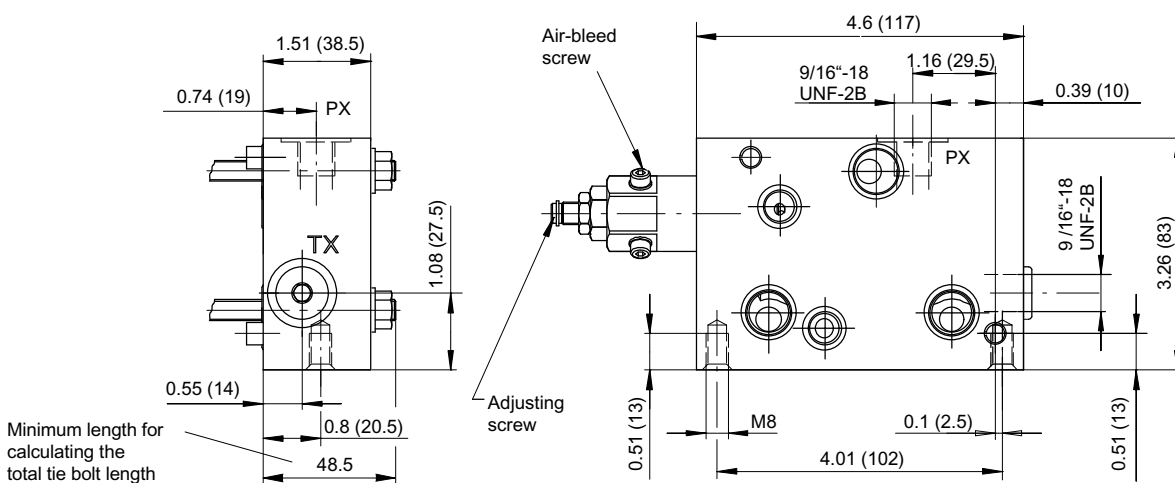

8.5 Load control valve with float position

8.5.1 Description

For terminating the block, this has an integral load-holding valve with anti-shock function for port A. The two seat valves in A and B to create the float position. When the directional valve is in the neutral position, actuator line A is shut-off with zero leakage and protected from unacceptably-high pressure peaks by an anti-shock function.

The mating directional valve is the last directional section in the block and must be a special version e.g. /02 (LC8S) or /24 (LP8S, LH8S) with spool type 4E. A typical application is the arm function in wheel loaders and front loaders.

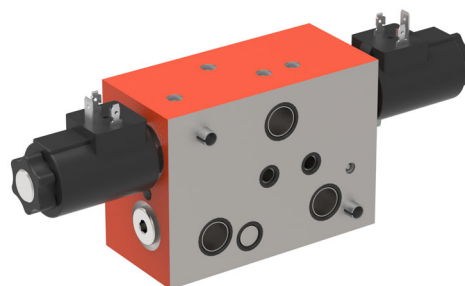

8.5.2 Technical data

General characteristics	Unit	Description, value
Inlet pressure	PSI (bar)	max. 3046 (210)
Actuator pressure	PSI (bar)	max. 3626 (250)
Port threads to ISO 11926		3/4"-16 UNF-2B
Pilot ratio S15 S30		1.5 : 1 3 : 1
Anti-shock valve adjustable	PSI (bar)	1450 ... 3626 (100 ... 250)
Pressure drop across load-control function	PSI (bar)	435 (30) at 16.64 GPM (63 l/min)
Nominal flow rate	VDC	12 or 24
Power consumption	Watt	50
Duty cycle	%	100
Connector socket		DIN 43650
Enclosure protection		AMP Junior Timer, GDM plug: IP65 Deutsch plug DT04-2P-EP04: IP67 (DIN EN 60529)

8.5.3 Overview of sections

Symbol	Description	Part number
	LU8SPUE-S15***-0U34G12 P= <ul style="list-style-type: none"> • end section • actuator port A: load control function pilot ratio 1,5 : 1 • nominal voltage 12 VDC ⇒ specify the pressure relief setting in bar	-
	LU8SPUE-S15***-0U34G24 P= <ul style="list-style-type: none"> • end section • actuator port A: load control function pilot ratio 1,5 : 1 • nominal voltage 24 VDC ⇒ specify the pressure relief setting in bar	-

	<p>LU8SPUE-S30***-0U34G12 P=</p> <ul style="list-style-type: none"> • end section • actuator port A: load control function pilot ratio 3 : 1 • nominal voltage 12VDC <p>⇒ specify the pressure relief setting in bar</p>	-
	<p>LU8SPUE-S30***-0U34G24 P=</p> <ul style="list-style-type: none"> • end section • actuator port A: load control function pilot ratio 3 : 1 • nominal voltage 24 VDC <p>⇒ specify the pressure relief setting in bar</p>	-

8.5.4 Connector socket

GDM plug to DIN 43650 -G..	AMP Junior Timer -J..-	Deutsch plug DT04-2P-EP04 -T..-

8.5.5 Dimension [in (mm)]

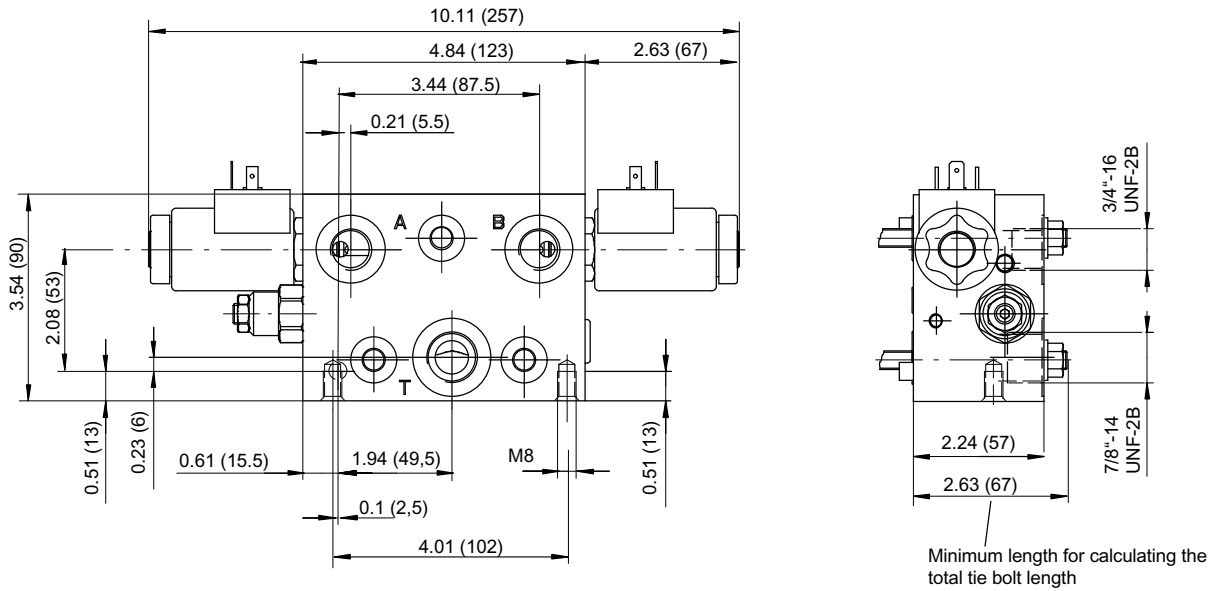

8.6 Safety valve for electro-hydraulic steering systems

8.6.1 Description

Block end section as safety valve for electro-hydraulic steering systems. When the electro-hydraulic steering is activated by energising the attached proportional valve (e.g. LC8S), the two 3/2 directional valves are also energised at the same time. As a result, the steering Orbitrol is disconnected. In automatic mode, if manual (i.e. emergency) steering corrections have to be made without first switching off automatic mode, a pressure develops in R or L, depending on the direction the Orbitrol is turned.

This pressure passes through the shuttle valve to a pressure switch. The signal from the pressure switch cancels the automatic function and all solenoids are de-energised. Thus, the Orbitrol is directly connected to the steering cylinder and the normal manual steering function is active.

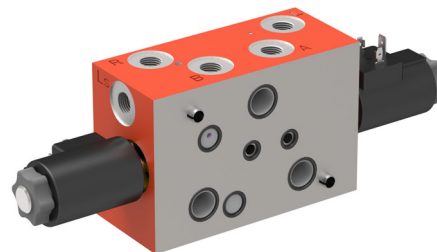

8.6.2 Technical data

General characteristics	Unit	Description, value
Inlet pressure	PSI (bar)	max. 3045 (210)
Flow rate	GPM (l/min)	6.60 (25)
Nominal voltage	V DC	12
Power consumption	Watt	27
Duty cycle	%	100
Connector socket		DIN 43650
Enclosure protection		AMP, GDM: IP65 DT: IP67 (DIN EN 60529)

8.6.3 Overview of sections

Symbol	Description	Part number
	LU8SPUL-0B14J24 <ul style="list-style-type: none"> • end section • connector socket: AMP Junior Timer • nominal voltage 24 V DC 	-

8.6.4 Connector socket

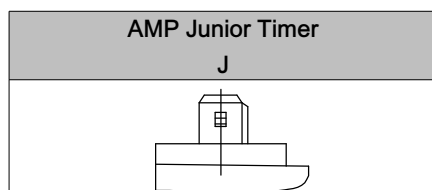

8.6.5 Dimensions

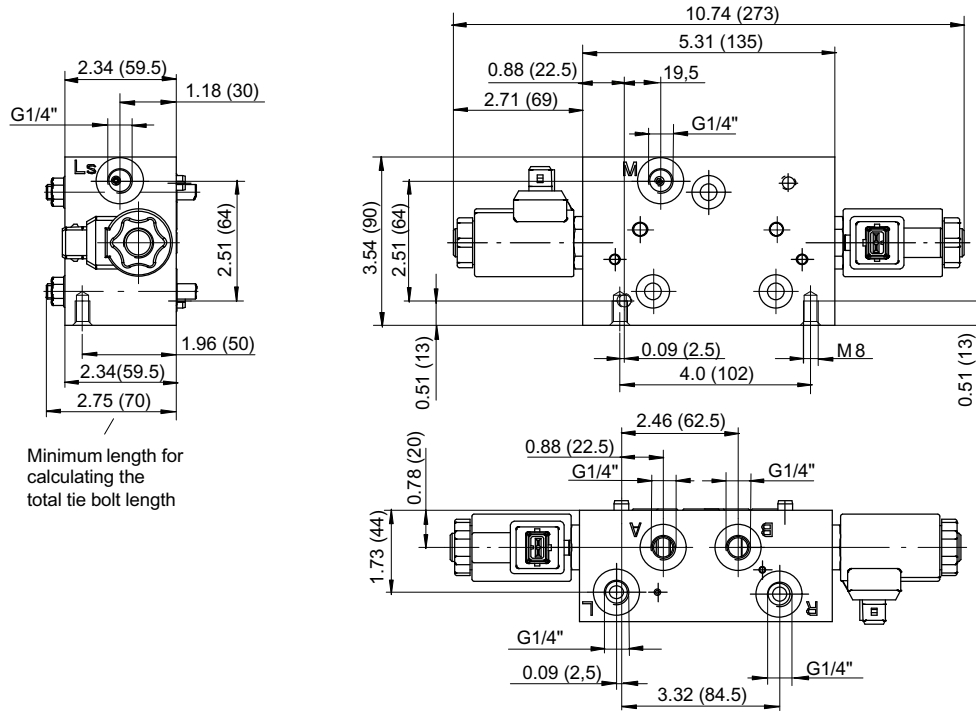

9 Fluid

The proportional directional valves require fluid with a minimum cleanliness level of ISO 4406 code 20/18/15.

We recommend the use of fluids that contains anti-wear additives for mixed-friction operating conditions. Fluids without appropriate additives can reduce the service life of valves.

The user is responsible for maintaining and regularly checking the fluid quality.

10 Accessories

10.1 Seat valves series SVH04

10.1.1 Single and multi-monoblocks for attaching to L.8S valves

10.1.1.1 Symbols

SVH04M228S-..

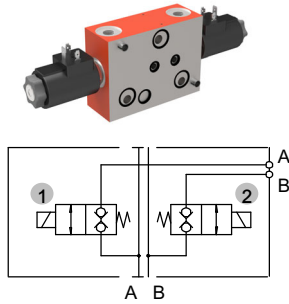

SVH04M448S-..

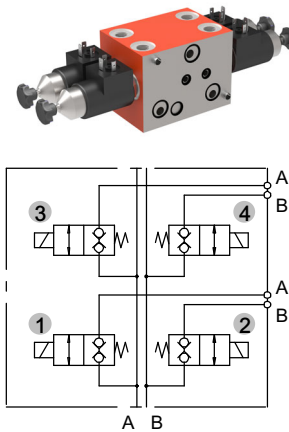

SVH04M668S-..

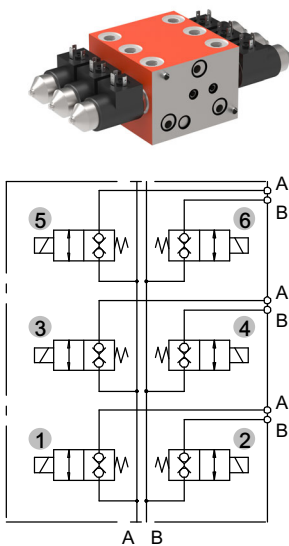

SVH04M888S-..

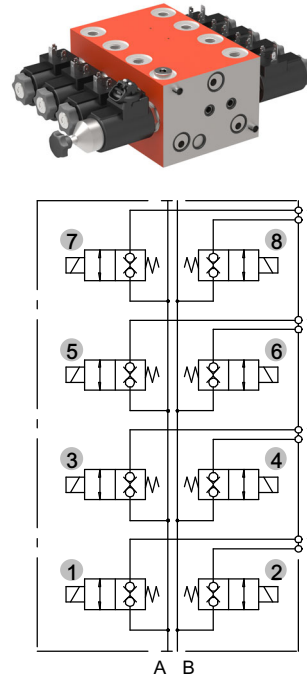

SVH04M008S-..

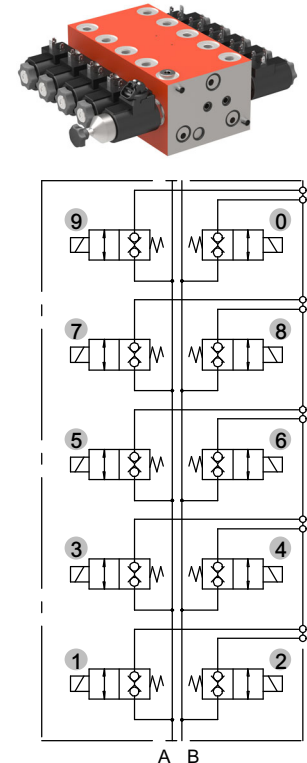

Detailed information see data sheet 100-P-00043.

10.2 Analogue system

10.2.1 Overview of components

Description	Ordering code	Data sheet
Electrical joystick FGE (demand-signal source)	(see datasheet)	100-P-700051
Plug Junior Timer 2-pole	100152575	
Plug Junior Timer complete	100152579	
Plug Deutsch DT04-2P-EP04	100608468	
Solenoid connection cable ELSK106-6	100153209	

10.3 Proportional amplifier EBM-300308-DS-MOBI

Description	Ordering code	Data sheet
Proportional amplifier EBM-300308-DS-MOBI	100034752	100-P-000146

10.4 Assembly kit

10.4.1 Description

To assemble the individual valve sections with assured functional reliability, 3 tie bolts and hex. nuts are necessary. Maximum tightening torque = 266 lbs (30 Nm). Tighten in 3 steps of 53 lbs (6 Nm), 142 lbs (16 Nm) and 266 lbs (30 Nm).

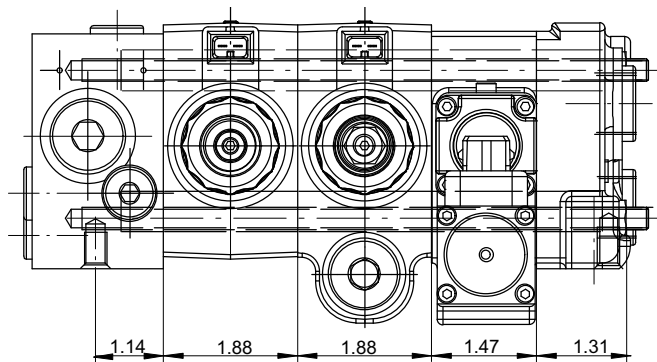

10.4.1.1 Ordering code

3 pcs. Shaft screws M8 x (required length in mm)
3 or 6 pcs. (depending on block configuration) Seal-Lock sealing nut M8, Part No: 100280470

Calculating the shaft screw length:

Inlet section + 1.88 (LP,LM,LH = 1.47) x no. of directional valve sections + width of the end section

Example:

$$1.14 + (1.88 \times 2) + 1.47 + 1.31 = 7.63 \text{ in.}$$

For ordering purposes, always round up to the calculated shaft screw length to the next 0.39 in.

In our example, we therefore need to order 3 pcs. shaft screws á M8 x 200 mm.

IMPORTANT: Maximum 10 directional sections in 1 valve block.

11 Liability

In the design and operation of hydraulic systems, all aspects of the potential failure modes and all planned operational conditions and uses of the equipment must be taken into consideration. Concerning risk assessment, please refer to the relevant Standards. The use of components that are not Original Bucher Replacement Parts and Accessories nullifies all warranty.

12 Note

This catalogue is intended for users with specialist knowledge. To ensure that all of the conditions necessary for the function and safety of the system are fulfilled, users must satisfy themselves as to the suitability of the units described here in. If there are any areas of doubt, please consult Bucher Hydraulics.

info.kl@bucherhydraulics.com

www.bucherhydraulics.com

© 2020 by Bucher Hydraulics GmbH, D-79771 Klettgau

All rights reserved.

Data is provided for the purpose of product description only, and must not be construed as warranted characteristics in the legal sense. The information does not relieve users from the duty of conducting their own evaluations and tests. Because the products are subject to continual improvement, we reserve the right to amend the product specifications contained in this catalogue.

Classification: 430.300. 410 100